

MILLTRONICS

**AUTOWEIGH FEEDER
SERIES 600**

Instruction Manual PL-586

April 2001

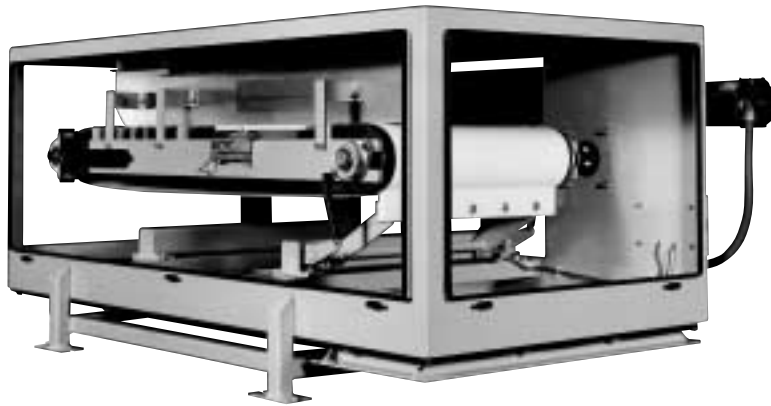

Safety Guidelines

Warning notices must be observed to ensure personal safety as well as that of others, and to protect the product and the connected equipment. These warning notices are accompanied by a clarification of the level of caution to be observed.

Qualified Personnel

This device/system may only be set up and operated in conjunction with this manual. Qualified personnel are only authorized to install and operate this equipment in accordance with established safety practices and standards.

Warning: This product can only function properly and safely if it is correctly transported, stored, installed, set up, operated, and maintained.

Note: Always use product in accordance with specifications.

Copyright Siemens Milltronics Process Instruments Inc. 2000. All Rights Reserved	Disclaimer of Liability
<p>This document is available in bound version and in electronic version. We encourage users to purchase authorized bound manuals, or to view electronic versions as designed and authored by Siemens Milltronics Process Instruments Inc. Siemens Milltronics Process Instruments Inc. will not be responsible for the contents of partial or whole reproductions of either bound or electronic versions.</p>	<p>While we have verified the contents of this manual for agreement with the instrumentation described, variations remain possible. Thus we cannot guarantee full agreement. The contents of this manual are regularly reviewed and corrections are included in subsequent editions. We welcome all suggestions for improvement.</p> <p>Technical data subject to change.</p>

MILLTRONICS® is a registered trademark of Siemens Milltronics Process Instruments Inc.

Contact SMPI Technical Publications at the following address:

Technical Publications
Siemens Milltronics Process Instruments Inc.
1954 Technology Drive, P.O. Box 4225
Peterborough, Ontario, Canada, K9J 7B1
Email: techpubs@milltronics.com

For the library of SMPI instruction manuals, visit our Web site: www.milltronics.com

Table of Contents

- Safety & Theory5**
 - Safety and General Precautions5
 - Theory of Operation6
 - Receiving and Unpacking.....6
- Mechanical Installation7**
 - Installation7
 - Start Up8
 - Changing the Conveyor Belt9
 - Belt Tension10
 - Belt Tracking10
 - Telescoper Adjustment.....10
 - Load Cell Replacement.....12
 - Quick Start Up Overview14
- Troubleshooting15**
 - Mechanical Troubleshooting15
- Preventative Maintenance17**
 - Recommended Preventative Maintenance Schedule18
 - General Maintenance19
 - Lubrication.....19
 - Feeder Storage Recommendations19

Safety & Theory

Safety and General Precautions

The Milltronics 600 Series weigh feeder is not considered a risk to those installing, operating or maintaining them compared to other industrial machinery, however, some risks to personal safety do exist. Through the use of proper and safe techniques these hazards can be eliminated.

Shock hazard

Although Milltronics electronics operate on standard 110 or 220 VAC power VAC, the equipment is often installed in wet environments and adjacent to conductive steel mounting framework. This voltage potential can be fatal under certain adverse circumstances. Always follow safe practices when working on or around the Milltronics electronics.

Turn off, lock-out, and tag the main disconnect switch "Do Not Energize" when connecting or working near the high voltage section of the integrator.

Warning!

Always follow established safe operating practices.

A weigh feeder can be dangerous. A pinch point exists between the slider deck and pulleys and the conveyor belt.

ALWAYS STOP the belt, lock-out, and/or place a "Do Not Energize" tag on the main disconnect.

It takes very little additional time to secure the weigh feeder.

In particular, follow this safe practice when:

- Replacing the belt,
- Placing or removing the calibration test chain,
- Working on or around the load cell,
- Working on or around the speed sensor.
- When any guards are removed.

Warning!

Whenever working near chain or belt drives, always be sure the guards are in place or the equipment is safely secured. The pinch points created by these drives can be serious.

Theory of Operation

Weighing feeders or weigh belts provide a means of weighing bulk material while being conveyed. This allows accurate rate of flow and totalized weight measurement without interrupting the flow of material in process. A weighing feeder also provides a means for controlling the rate of flow of the product being conveyed.

As in static weighing, in-motion weighing requires accurate transmission of the product load to a strain gauge load cell. The resultant voltage signal corresponding to weight is transmitted to the Integrator and becomes one of the two inputs required for integration.

Unlike static weighing, in-motion weighing requires a second input, which is a pulse signal proportional to the speed of the conveyor belt. Each belt speed sensor pulse represents a fixed distance of the travel.

Since the force measured by the load cell is represented as weight per unit length, it can be multiplied by the distance of the belt travel (one speed sensor pulse) to provide product weight for that segment of the belt.

Example: lbs/ft x ft = lbs

A summation of the samples provides total throughput weight of product across the scale. With proper scaling (calibration), the total weight takes on meaningful units of measure (pounds, short tons, long tons, metric tons, etc.).

Receiving and Unpacking

A thorough and systematic receiving inspection should be performed immediately upon receipt of the Milltronics systems.

Resolution of shipping damage claims and missing items can be made quickly and efficiently if damage or discrepancies are documented promptly on receipt of the shipment.

1. Check for possible shipping damage. Damaged boxes or crating suggests possible damage to the equipment contained therein. Notify the carrier immediately. Document all visible damage immediately with either photographs or a joint inspection with the carrier's claims representative.

Note:

Do not remove equipment from shipping crates or boxes until this has been done.

Reconcile the number of containers received against the inland bill of lading to assure shipment is complete to the container level.

2. After the considerations in Step #1 are satisfied, unpack one container at a time. Reconcile the contents against the packing slip.

Note:

Contact Milltronics immediately if discrepancies are found. Contact information is provided on the back cover of this manual.

Mechanical Installation

Your weigh feeder has been designed, assembled, and factory tested for your specific application. The following general instructions will assist you in the proper installation and operation of the machine. It is suggested that this information be given serious attention before the equipment is put into operation.

Notes:

1. Refer to the mechanical drawings sent with this manual prior to commencing with installation. These drawings will provide you with important general mounting dimensions and other specifications.
2. Do **NOT** remove the orange load cell shipping bolt(s) until the installation is complete. Failure to follow this instruction may result in load cell damage.
3. Do **NOT** weld on or near the weigh feeder while the load cell is connected to the electronic integrator. Damage to the integrator may result if the load cell is not disconnected from the integrator.
4. Following a scheduled, preventative maintenance program will assure optimum performance and long equipment life.

Installation

Install the unit in its desired location according to the supplied mechanical drawing(s) in the following manner:

1. Align the in-feed section of the weigh feeder with the discharge of the feed device. Prevent twisting or misalignment, which may induce stress on the weigh section.
2. It is essential that the unit be securely fastened to a rigid, level structure. Use a level for installation and shim as necessary. Again, prevent any twisting of the frame, as it may affect feeder performance.
3. Construct the necessary support framework to provide a sturdy, rigid base. Vibration isolators are recommended if the location is subject to moderate or heavy vibration.

Note:

If your system has a permanently lubricated gear motor, then disregard Step 4

4. Check the gear reducer oil level.
5. Flexible in-feed connections are recommended for all applications.
6. Connect the proper electric supply to the motor and/or motor controller, following the interwiring diagram supplied with this manual. The AC/DC motor controller (if present) must be grounded to minimize noise to the electronic integrator. Refer to the applicable wiring diagram to make all electrical connections between the electronic integrator and the weigh feeder.
7. Remove the ORANGE shipping bolt, which is attached to the load cell. This bolt supports the weighbridge during transport and installation. Please note that there are

two bolts attached to the bottom of each load cell: the orange one is the previously mentioned shipping bolt; the other bolt is the overload bolt. **DO NOT** loosen or tighten this overload bolt—it has been factory set to minimize the possibility of load cell damage resulting from incidental overload.

8. Before starting the machine, make a final check to see that the conveyor belt is free from all tools and foreign objects.

Start Up

Your weigh feeder has been factory run-in for a minimum of four hours; thus it should require little adjustment. However, periodic inspections of the belt tracking are recommended.

Start the belt and observe rotation.

WARNING!
Turn off and lock out all power sources before correcting rotation if required. On DC motors, reverse the armature wires. On AC motors, reverse 2 of the 3 motor wires.

Start the belt again and observe the machine as it is running. If the belt appears not to be tracking correctly, please see the "Belt Tracking" section on page 10.

Shear Gate

The shear gate on the inlet of the weigh feeder has been factory set to allow the maximum feedrate capacity requested by the customer. No field adjustment should be necessary. Consult the factory if you have a problem.

Skirtboards

The skirtboards have also been factory set to proper specifications. Note that near the inlet, the skirtboards are very close to the belt. However, toward the discharge end of the feeder, the skirtboards are 1/8" to 3/16" higher off of the belt. This relieving effect minimizes the possibility of material becoming lodged between the skirtboard and the belt.

In addition to the previously mentioned relieving effect, note also that the distance between the skirtboards is greater at the discharge end than at the inlet end (by about 1/2"). This tapering is done also for material flow reasons--it will help the product move down the belt without "bottlenecking."

Periodic adjustments of the skirtboards should not be necessary. If adjustment is necessary, please follow the above guidelines.

Your system may have been supplied with soft PVC seal strips if the product being conveyed is a fine powder. Refer to the following drawing for proper location of the seal strips on the skirtboards.

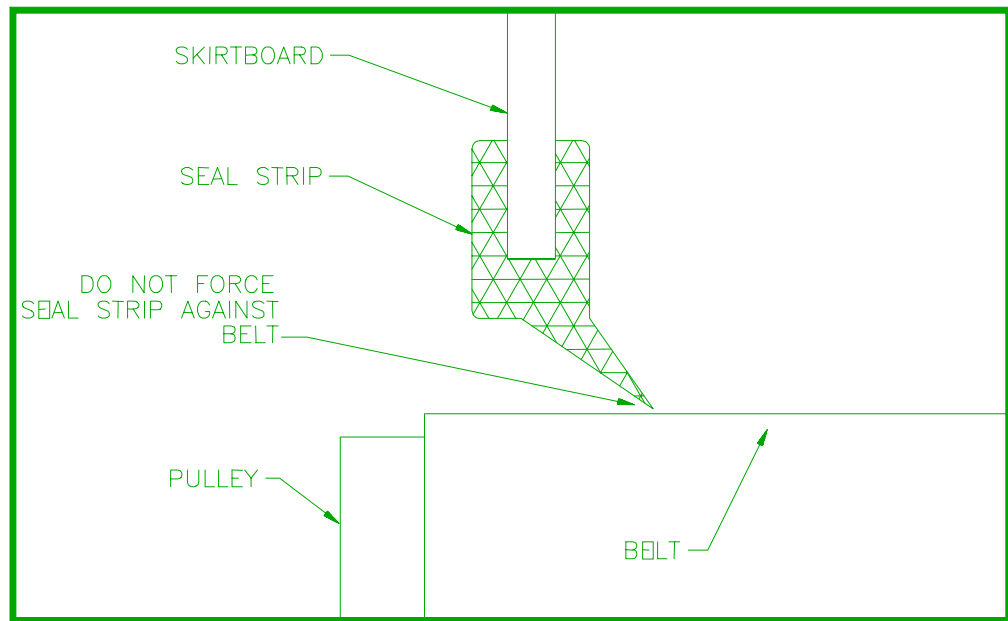

Changing the Conveyor Belt

1. Open and remove the access and non-access side covers (omit this step on open construction models).
2. Mark the position of the telescopers for reference. This will be handy when you re-install the belt. Loosen the telescopers to remove tension from the belt.
3. At the discharge end of the conveyor, you will find the belt scraper spring tensioner. Unhook the spring on both sides of the belt scraper arm and let the belt scraper swing down away from the belt.

Note:

Skirtboard removal or adjustment is not normally necessary to perform belt removal or installation, nor is it recommended.

4. From the access side of the feeder at the discharge end, grab the edge of the belt on the top and bottom. Gently pull the belt over the side rail, making sure that the leading edge of the belt does not catch on the side rail.
5. Now repeat step #4 on the inlet end of the feeder. Again, be careful not to cut or scrape the belt on the side rail.
6. When both ends have been pulled to the outside of the side rail, you may grab the belt in the middle and slowly remove the belt. As the belt is removed, it is recommended that you mark which direction the belt was rotating. This is to allow you to re-install the belt in the same direction. Care must be taken in storing the belt to prevent kinks or other sorts of damage.
7. With the belt removed, inspect the feeder for material build up, lodged particles, and signs of wear, paying close attention to the weigh section area. Care must be taken

when cleaning the weigh section area, as only 25 lbs. of pressure or less placed on the weighbridge could cause loadcell damage.

8. Reverse steps 1-6 for re-installing the same belt.

Note:

On a new replacement belt, there may be an arrow printed on the underside of the belt. This arrow indicates what direction the belt should rotate when it is installed. If there is no arrow, rotation of the belt may be in either direction. Anytime a new belt is installed, a belt tracking procedure will need to be performed (see page 10)..

Belt Tension

The ideal belt tension for any weigh feeder is just enough tension to prevent the belt from slipping on the drive pulley. This is done to minimize the effects that the belt may have on weighing accuracy. Often times the sole cause of an inaccurate weigh feeder is that the belt tension is too high.

Due to varying applications, a specific measure of belt tension cannot be given. As a general guideline, the bottom of the belt should droop 1-2 inches for every four feet of horizontal length of the weigh feeder. Please note that this is only an approximate specification, as your application may require more or less tension due to varying belt loading and other operating characteristics.

Belt Tracking

1. Before attempting to track the belt, make certain that the belt scraper is in place. In addition, make certain that the belt tension is near the factory recommended specifications before attempting to track the belt. See the "Belt Tension" segment on page 10 for details.
2. Finally, be sure that the feeder is level and true and that the installation has not warped or twisted the frame. Check for true and square between the head and tail pulley.
3. Turn on the feeder and observe its tracking line on the head and tail pulleys.
 - a. If the belt is drifting toward one side of the feeder, then telescoper adjustment on either side of the machine will be necessary (see below).

Telescoper Adjustment

1. First, determine which side of the machine you want to adjust. Compressing the telescoper on one side will cause the belt to drift toward that side of the machine. Conversely, extending the telescoper will cause the belt to drift away from that side of the machine.
2. Adjustment is done by first loosening the jam nut, and then turning the adjusting screw in the desired direction. Often times, only a small amount of adjustment (1 turn or less) will be required.
3. Observe the results of the adjustment and then readjust, if necessary.

4. Steps two and three may need to be repeated a number of times to obtain perfect belt tracking.
5. Please be aware that as you extend or compress the telescoper, you may be changing the belt tension. If you find that the belt tension has increased (or decreased) considerably while attempting to track the belt, then both telescopers must be compressed (or extended) and the belt tracking process must be re-started. It is very important that the belt tension be maintained at a relatively low level. For this reason, it is a good idea to extend one telescoper while compressing the other to obtain proper belt tracking.
6. Don't forget to re-tighten the jam nut located on the telescoper to maintain the new telescoper position when the tracking procedure is complete.
7. If you are having problems tracking the belt, consult the factory. Common causes of belt tracking problems are: uneven or improperly distributed product loading, twisted frame, product build up on head or tail pulleys, etc...

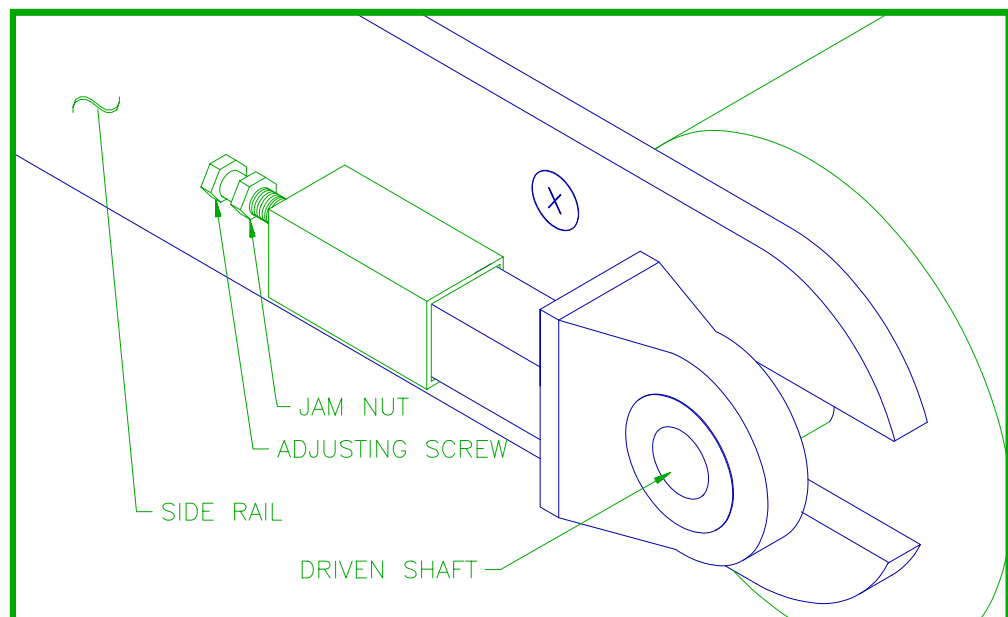

Load Cell Replacement

If a load cell on the series 600 has been damaged and is not functioning or if you are changing the capacity, you will need to replace one or all load cells.

Note:

Please read and understand all of the instructions before proceeding with the replacement. Contact the factory for assistance if you have any questions or problems.

Removing Old Load Cell

1. Confirm the new replacement load cell is correct and functional

Using a digital volt meter or ohm meter, verify that the resistance of the new load cell matches the resistance printed on the specification sheet that came with the load cell. If the resistances do not match, the load cell may be damaged. Consult the factory.

2. Disconnect the load cell being replaced from the junction box

Verify that the load cell is connected according to the interwiring diagram supplied with this manual. Disconnect the load cell from the load cell junction box. Free the load cell cable from the feeder so it is hanging free from the load cell.

3. Install the shipping screw

Install the shipping screw (1/4-20 x 1 lg) through the bottom load cell mount and into the load cell. Tighten the shipping screw until the load cell bottoms out on the overload screw.

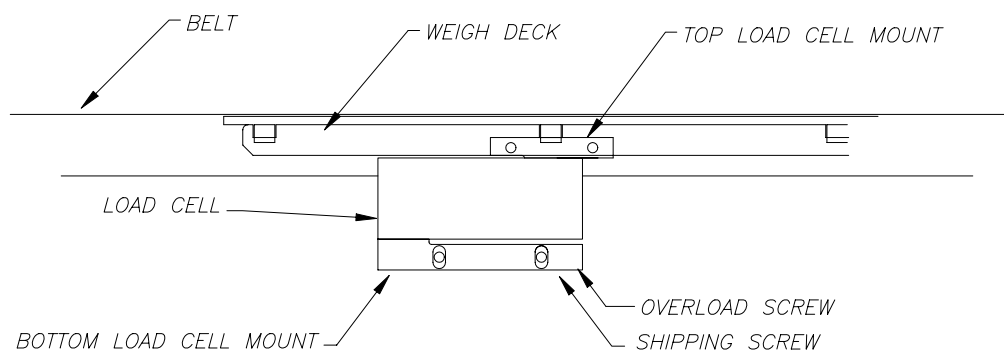

4. Remove the top load cell mount bolts

Support the scale deck and remove the two top load cell mount bolts. Be careful not to move the deck since it is still attached to the load cell on the other side of the feeder.

5. Remove the bottom load cell mount bolts

Remove the two bottom load cell mount bolts. The load cell is now held in place only by the shipping bolt.

6. Remove the shipping screw

Support the scale deck with a block of wood or have an assistant hold it. Remove the shipping screw and slide the load cell off the feeder.

Installing The New Load Cell

1. Install the shipping screw

Slide the new load cell into position and carefully screw in the load cell shipping bolt. Do not over tighten the screw.

2. Install the bottom load cell mount bolts

Install the two bottom load cell mount bolts. Tighten them by hand. Now re-tighten the shipping bolt so the load cell is resting against the overload stop.

3. Install the top load cell mount bolts

Install the two top load cell mount bolts. Tighten them by hand.

4. Tighten bolts

Start with the bottom load cell mounting bolts and tighten them to 200 in-lb torque. Now tighten the two top load cell mounting bolts to 200 in-lb torque.

5. Remove the shipping screw

6. Connect the load cell

Route the load cell cable to the junction box and connect the load cell according to the supplied interwiring diagram

Repeat for other load cells if necessary

Final Steps

1. Power up the integrator

Using the appropriate integrator menu, verify that the new load cell(s) are operating correctly.

2. Zero calibrate the unit

Refer to the integrator manual for the procedure for zero calibration. Record zero calibration procedure results.

3. Span calibrate the unit

Refer to the integrator manual for the procedure for span calibration. Record span calibration procedure results.

4. Re-check zero calibration

Run another zero calibration and record the results. Verify that the zero repeated to the same value recorded in step 2.

5. Confirm calibration with material test

Refer to the integrator manual. If possible, run material tests to verify correct calibration before placing the feeder back in operation.

Quick Start Up Overview

1. Verify that the weigh feeder is installed properly as described in the "Mechanical Installation" section on page 7 of this manual. Verify that the belt is tracking and the shear gate (if used) is properly set.
2. Verify that all associated electrical equipment is properly connected per the supplied interwiring diagram.
3. Verify data on design data sheet sent with this manual is correct and modify if required.
4. Refer to the supplied integrator/controller manual for calibration and configuration information.

Troubleshooting

Mechanical Troubleshooting

If operating errors are suspected to be caused by a mechanical problem, it is useful to review the mechanical installation procedures in the "Mechanical Installation" section on page 7 of this manual, followed by a thorough visual inspection of the system.

Review and check the common problems listed below.

Note:

If you have difficulty determining the cause of the problem you are experiencing, contact the Service Department at Milltronics, Inc. Be sure to have the Model Number and Serial Number of your system and all of the calibration and set up parameters available *before* calling. Your time spent trouble shooting the system will be minimized if you record and fax the information to Milltronics before calling or checking other parts of the system.

The following are some of the more common mechanical problems experienced with weigh feeder systems:

Zero Drift, non-repeatability, or non-linearity.

Check for these following conditions:

- Weigh deck alignment
Verify weigh deck alignment is as accurate as possible. Improper alignment is the most common mechanical problem affecting scale accuracy. Contact the factory if you find a problem.
- Material build up on weigh section or pulleys.
- Belt mis-tracking.
- Belt too tight.
- Load cell bolts loose.
- Speed sensor coupling, pulley, or deck slippage.
- Material build-up between the weigh deck and feeder frame.
- Load cell shipping bolt (orange) never removed.
- Head or tail pulley too high or low, relative to deck/slider bed alignment.
The head and tail pulleys should be at least 1/8" lower than the approach and retreat slider beds.

Preventative Maintenance

The Milltronics weigh bridge and feeder requires no routine maintenance. Periodic housekeeping and follow-up calibration on a routine schedule allows continuing high accuracy performance from the scale.

Alignment of the weigh deck with the approach and retreat sections is of paramount importance for accurate weighing. Periodic measurement to verify alignment is recommended.

Depending on accuracy expectations and operational constraints, the frequency of routine maintenance will vary from application to application. The maintenance schedule on page 18 is recommended by Milltronics, Inc. to maintain top performance and accuracy of the system. An eight (8) hour day operating schedule, moderate weather conditions, and a reasonably clean environment, are assumed for the recommended maintenance. A longer operating day, severe weather or dusty conditions will dictate a more rigorous maintenance schedule.

Note 1:

In extraordinary climatic or environmental conditions, special lubricants may be required.

Note 2:

In corrosive environments, more frequent lubrication is required to purge contaminants.

Recommended Preventative Maintenance Schedule

Item	Required maintenance	Frequency	Comments
Weigh Deck	Blow or brush off any material build-up.	Weekly	More frequently in dirty environments
Belt Tracking	Visually inspect to assure belt remains trained.	Daily	None
Calibration Span Check	Use Cal Chains or E-Cal Calibration	Monthly	See Calibration Section of Integrator Manual
Calibration Verify Belt Zero		Daily or at least once a week	See Calibration Section of Integrator Manual
Bearings	Inspect and lubricate	Every 10,000 hrs, or as required	Use #3 NLGI Grade Lithium base grease
Chain and Sprocket (if present)	Inspect, lubricate and clean as required		Solvent clean and lubricate with 30 Weight oil. Adjust Chain Tension, if necessary.
Electric Motor (DC)	Check Brushes	Every 6 months	Replace as necessary
Electric Motor (AC)	None	None	Bearings are sealed and permanently lubricated
Gear Reducer	Check oil level	Monthly	Refer to manufacturer maintenance manual
Gear Reducer	Replace Oil	Every 2,500 Hours	See note above

Maintenance

General Maintenance

The equipment should be cleaned periodically to maintain a high level of accuracy. Any excess accumulation of product should be removed to minimize potential damage to the mechanical components and scale accuracy.

When the belt is removed for cleaning, always check the weigh section area for material build up. Clean as required for proper performance. Always remember that this equipment is not just a conveyor, it is also a scale. Accuracy will not be maintained unless the equipment is properly maintained.

Abrasions, cuts, or ragged edges on the belt will create performance problems. Belt replacement is recommended if the belt becomes ragged or torn.

Lubrication

All head and tail pulley bearings are pre-greased at the factory. These bearings should be field greased periodically. The frequency of lubrication may vary due to specific operating conditions. Some dry, dusty applications may warrant weekly greasing, while other less harsh applications may need greasing only once or twice a year. In no case, however, should more than 10,000 hours elapse between regreasing operations.

If there is a gear reducer supplied with your weighfeeder, it has an initial break-in period. After the first 250 hours of operation, the gear box(es) should be drained and refilled to the proper level(s). Subsequent oil changes should be done every 2500 hours thereafter. See the gear reducer manual for further details.

Feeder Storage Recommendations

In the event that a feeder will be stored for a period of three months or more, it is recommended that the following guidelines be followed:

1. Load Cell Care

The load cell shipping bolts should be installed anytime the feeder is moved. It may be a good idea to install these shipping bolts during the storage period as an extra safety measure. Do not forget to remove the shipping bolts upon re-installation.

2. Gear Reducer/Gear Motor

The gear reducer should be uncoupled from the feeder drive shaft and the motor. After the reducer is removed, it is recommended that all shaft surfaces be liberally greased with an appropriate lubricant, such as Never-Seez. This will aid in reassembly.

In addition, the gear reducer should be filled completely with an appropriate gear oil. This is to prevent the formation of any oxidation that may occur. When the equipment is re-installed, this gear oil should be completely drained and then the reducer should be refilled to the appropriate level(s).

3. Electrical

To prevent oxidation, a desiccant or some type of moisture removal material should be placed in all electrical junction boxes component cabinets. This includes the load cell junction box, the integrator cabinet, and the SCR enclosure (if present).

4. Lubrication

All greasable deck rollers should be greased.

5. Belt Care

Finally, to prevent belt damage, the belt tension should be reduced to a minimum. **DO NOT STORE THE FEEDER IN DIRECT SUNLIGHT**, as this will cause premature breakdown of the belt. Do not forget to re-adjust the belt tension at the time of re-installation.

www.milltronics.com

MILLTRONICS

Siemens Milltronics Process Instruments Inc.
1954 Technology Drive, P.O. Box 4225
Peterborough, ON, Canada K9J 7B1
Tel: (705) 745-2431 Fax: (705) 741-0466
www.milltronics.com

© Siemens Milltronics Process Instruments Inc. 2001
Subject to change without prior notice



Printed in Canada