

The Milltronics Single Idler Belt Scale (MSI) is one of the most advanced single idler belt scales available. It provides continuous in-line weighing on a variety of products in primary and secondary industries. It is proven in a wide range of tough applications from extraction - in mines, quarries and pits - to power generation, iron and steel, food processing and chemicals. The MSI is suitable for monitoring such diverse products as sand, flour, coal or sugar.

The MSI's patented use of parallelogram style load cells results in fast reaction to vertical forces, ensuring instant response to product loading. This enables it to provide outstanding accuracy and repeatability even with uneven loading and fast belt speeds.

Operating with one of Milltronics' microprocessor-based integrators, the MSI provides indication of flow rate, totalised weight, belt load and belt speed of bulk solid materials on a belt conveyor. A Milltronics speed sensor monitors conveyor belt speed for input to the integrator.

The MSI is installed in a simple drop-in operation and may be secured with just four bolts and an existing idler set, secured to the dynamic beam. With no moving parts, maintenance is kept to a minimum, with just periodic calibration checks required.



### Product Features

- Outstanding accuracy and repeatability
- Unique parallelogram style load cell design
- Fast reaction to product loading
- Capable of monitoring fast-moving belts
- Rugged construction

## Technical Specifications

### Accuracy

- $\pm 0.5\%$  of totalization over 5 to 1 operating range

### Belt Width

- 18" to 96" in CEMA sizes, 500 to 2000 mm in metric sizes (refer to Outline Dimensions section)

### Belt Speed

- up to 4 m/s (800 fpm)

### Capacity

- up to 5000 TPH at maximum belt speed

### Conveyor Incline

- $\pm 20^\circ$  from horizontal, fixed incline
- up to  $\pm 30^\circ$  with reduced accuracy

### Conveyor Idler

- flat to  $35^\circ$
- up to  $45^\circ$  with reduced accuracy

### Idler Diameter

- 50 to 180 mm (2 to 7")

### Idler Spacing

- 0.5 to 1.5 m (1.5 to 5.0 ft)

### Load Cell

- construction: stainless steel with superior moisture protection
- excitation: 10 Vdc nominal, 15 Vdc maximum
- output: 2 mV / V excitation at rated load cell capacity
- non-linearity: 0.02% of rated output
- hysteresis: 0.02% of rated output
- non-repeatability: 0.01% of rated output
- capacity: maximum ranges: 50, 100, 250, 500, 750, 1000 lbs.
- overload: safe 150% of rated capacity
- ultimate 300% of rated capacity
- temperature:
  - 40 to 85 °C (- 40 to 185 °F) operating range
  - 18 to 65 °C (0 to 150 °F) compensated
- mounting dimensions: identical for all capacities

### Hazardous Locations

- with the use of approved intrinsically safe barrier strips

### Weight

- see chart, Outline Dimensions section

### Approvals

- CE compliant

## Mounting

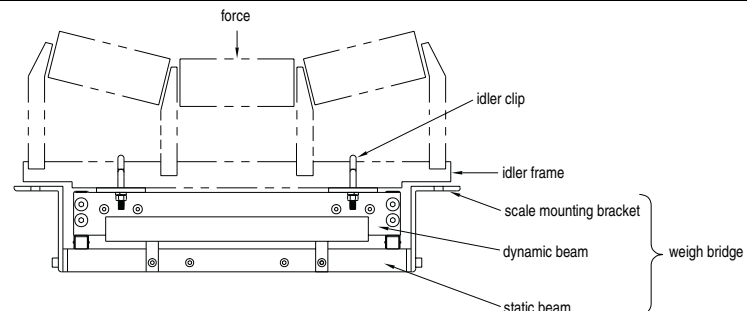
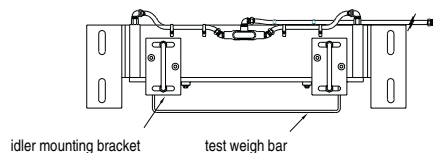

Specifications are subject to change without notice.

# Single Idler Belt Scale-MSI

## Dimensions

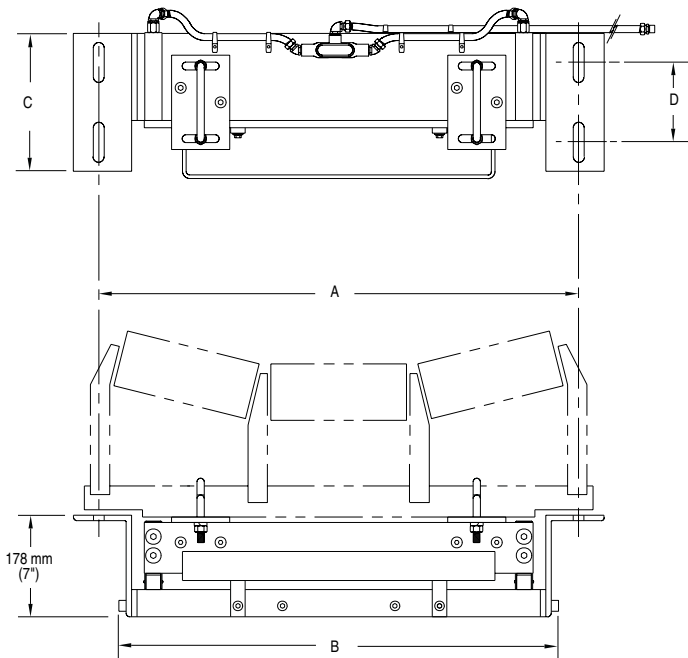

conveyor belt width	mounting scale width 'A'	minimum drop-in width 'B'	'C'	'D'	weight
18"	27"	24.5"	9.5"	5.5"	82 lbs.
20"	29"	26.5"	9.5"	5.5"	85 lbs.
24"	33"	30.5"	9.5"	5.5"	90 lbs.
30"	39"	36.5"	9.5"	5.5"	99 lbs.
36"	45"	42.5"	9.5"	5.5"	107 lbs.
42"	51"	48.5"	9.5"	5.5"	116 lbs.
48"	57"	54.5"	12"	8"	162 lbs.
54"	63"	60.5"	12"	8"	174 lbs.
60"	69"	66.5"	12"	8"	185 lbs.
72"	81"	78.75"	12"	8"	235 lbs.
84"	93"	90.75"	12"	8"	261 lbs.
96"	105"	102.75"	12"	8"	288 lbs.

conveyor belt width	mounting scale width 'A'	minimum drop-in width 'B'	'C'	'D'	weight
500 mm	740 mm	677 mm	241 mm	140 mm	37 kg
650 mm	890 mm	827 mm	241 mm	140 mm	40 kg
800 mm	1040 mm	977 mm	241 mm	140 mm	44 kg
800 mm	1090 mm	1027 mm	241 mm	140 mm	48 kg
1000 mm	1240 mm	1177 mm	241 mm	140 mm	52 kg
1000 mm	1290 mm	1227 mm	305 mm	203 mm	73 kg
1200 mm	1450 mm	1387 mm	305 mm	203 mm	78 kg
1200 mm	1540 mm	1477 mm	305 mm	203 mm	83 kg
1400 mm	1650 / 1740 mm	1587 / 1677 mm	305 mm	203 mm	88 kg
1600 mm	1900 / 1940 mm	1837 / 1877 mm	305 mm	203 mm	93 kg
1800 mm	2100 / 2140 mm	2037 / 2077 mm	305 mm	203 mm	98 kg
2000 mm	2300 / 2340 mm	2237 / 2277 mm	305 mm	203 mm	103 kg

## Wiring

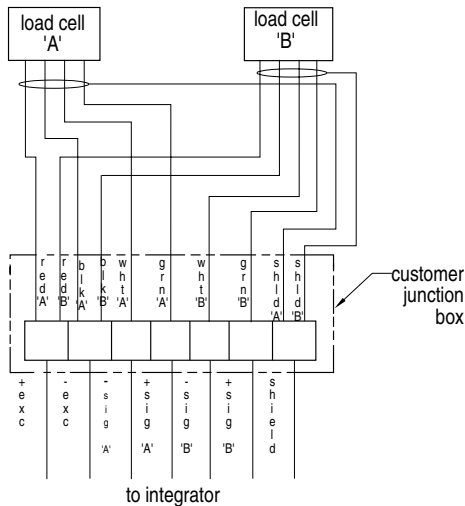
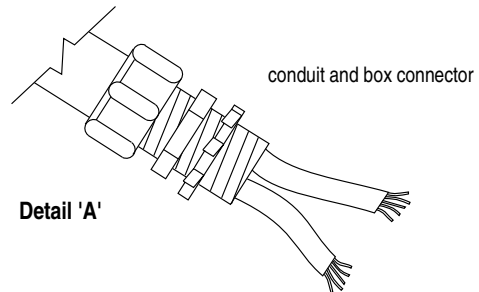
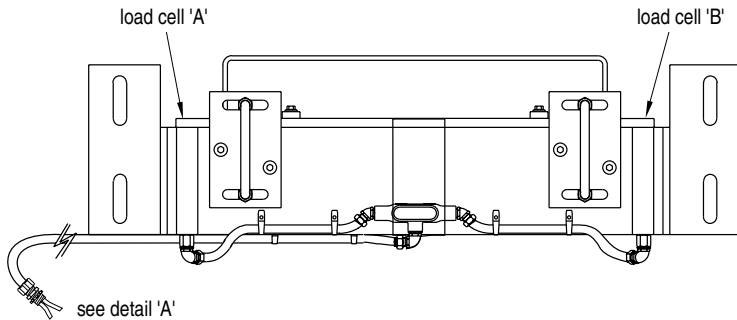

Australia	Tel.: +61 3-9695-2400	Fax: +61 3-9695-2450
Belgium	Tel.: +32(0)3326 45 54	Fax: +32(0)3326 05 25
Canada	Tel.: +1 705-745-2431	Fax: +1 705-741-0466
France	Tel.: +33 4 42 65 69 00	Fax: +33 4 42 58 63 95
Germany	Tel.: +49 721 595 4607	Fax: +49 721 595 4937
Hong Kong	Tel.: +85 2-2856-3166	Fax: +85 2-2856-2962
Mexico	Tel.: +52 5 575-27-28	Fax: +52 5 575-26-86
The Netherlands	Tel.: +31(0)76 542 7 542	Fax: +31(0)76 542 8 542
Switzerland	Tel.: +41 21 791 58 28	Fax: +41 21 791 58 40
United Kingdom	Tel.: +44 1905-450500	Fax: +44 1905-450501
United States	Tel.: +1 817-277-3543	Fax: +1 817-277-3894

[www.milltronics.com](http://www.milltronics.com)