

APX®

Nozzle-mix line burner



- Nozzle-mixing line burner for use with low pressure natural gas, propane and butane
- Eliminates leakage with its single-piece, aluminium extrusion body design
- Cooler oven walls due to deeper penetration inside the oven (wall-mounted applications)
- Independent of variable process air-flows (in-duct applications)
- Corrosion resistant main gas/air body and durable stainless steel mixing plates
- Up to 40:1 turndown
- Up to 1.4 MBtu/h per foot
- Packaged units up to 15 ft in length

Product description

MAXON APX® burners are packaged nozzle-mix line burners, especially designed for fresh or low temperature recirculating air heating applications.

The APX® burner is a value engineered design utilizing a single aluminium extrusion for both its main air and fuel manifolds. Its single-piece, seamless body design eliminates burner leakage and maximizes burner performance.

- 1) Gas/air body
- 2) Air box
- 3) Gas pipe
- 4) Mixing plate
- 5) Side plate

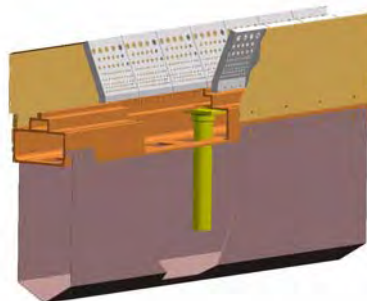
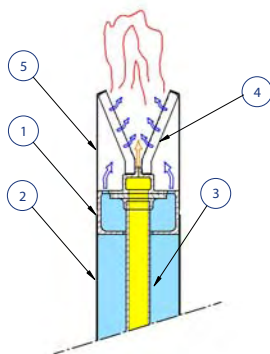

The particular drilling pattern of the air/gas-mixing body provides increased turbulence as well as uniform air distribution across the entire burner-length. This results in better gas/air mixing, shorter flames, more resistance to cross-flows and much lower emissions.

The design of the APX® burner allows for high turndown without premixing fuel and air at low firing rates. Low emissions are maintained through precise aeration of the flame along its length. This progressive aeration of the flame is achieved with the advanced mixing plate design of MAXON NP AIRFLO® line burner.

The APX® burner is built in 2 main versions, both available in lengths of 0.5 ft up to 15 ft

- A **wall-mounted APX® burner** to be externally mounted on oven- or dryer walls.
With a flame that exits the mixing chamber more than 6 in. downstream from the burner mounting flange, it is possible to penetrate oven panels up to 6 in. thickness without risking damage to oven structure from flame impingement.
- An **in-duct APX® burner** to heat-up low temperature process air flows.

For both versions, you can choose between:

- the **standard APX® burner** with 1 or more gas-and air inlet connections on the back of the burner, depending on the burner length.
- the **packaged APX® burner** equipped with one or more low horse-power paddle wheel fans, which resist possible particle build-up and provide higher air pressures.

Additionally, the APX® in-duct burner is also available as a "slide-in-unit", with a mounting plug or plate which can be easily flanged onto the duct.

A complete product overview is shown in "Specifications of APX® burners" - page 4-21.9-13.

Special grid versions or burner lengths extending 15 ft are also available. Contact MAXON for more information.

Available APX® sizes

Whatever APX®-version has been selected, the typical burner data per foot of burner are equal and shown in the below table. Note that these are typical data, which may slightly vary depending on the application and/or process design data.

Typical burner data			
Fuel: natural gas with 1000 Btu/ft ³ HHV - sg = 0.6 [1]			
Combustion air: 60° F - 21 % O ₂ - 50 % Humidity - sg = 1.0 [1]			
Stated pressures are indicative. Actual pressures are a function of air humidity, altitude, type of fuel and gas quality.			
		Fresh process air firing 21 % O ₂ - 15° C	Recirculating air firing (low O ₂ to almost inert higher upstream temperatures)
Max. capacity per foot	[2] MBtu (HHV)	1.36	1.0
Max. flame length (fresh process air - 21 % O ₂ - 60° F)	[3] ft	3 to 5	7 to 10
Turndown		40:1	30:1
Comb. air pressure at max. capacity	[4] "wc	8.4	6.4
Corresponding excess air factor	[5] n	1.1	1.3
Natural gas pressure at max. capacity (SP drillings)	[6] "wc	31.3	17.3
Natural gas pressure at max. capacity (LP drillings)	[7] "wc	16.5	9.2

[1] sg (specific gravity) = relative density to air (density air = 0.0763 lbs/ft³(st))

[2] Advised maximum capacities per ft. Overfiring is possible (up to 20 %) if special considerations are taken. Overfiring will give longer flames. Contact MAXON for more information.

[3] Typical flame lengths for shown excess air and capacity. Process oxygen levels, process velocities and air distribution may influence flame length. Contact Maxon for detailed information.

[4] Differential air pressure between burner test connection and combustion chamber for burner commissioning.

[5] Advised excess air factor for given capacity and optimal burner performance. Higher excess air factor will reduce flame length. Contact MAXON for more information.

[6] Differential natural gas pressure between burner gas test connection and combustion chamber (SP = standard pressure drillings).

[7] Differential natural gas pressure between burner gas test connection and combustion chamber (LP = low pressure drillings).

Applications

MAXON APX® burners are installed in a wide variety of applications.

The **wall-mounted APX® burner** is typically used on low temperature ovens with air recirculation (food, canning, construction materials, etc.).

The **in-duct APX® burner** is perfectly suitable for direct air heating. The clean hot air generated by the burner, meets most of the local requirements for make-up air systems, independent from possible variations of the process air flow (make-up, paint shops,...).

Besides make-up air heating and low temperature ovens, the APX® burner is widely used in all kind of drying applications, with fresh process air, or in recirculating low oxygen/ high humidity atmospheres (paper, food, gypsum, ...).

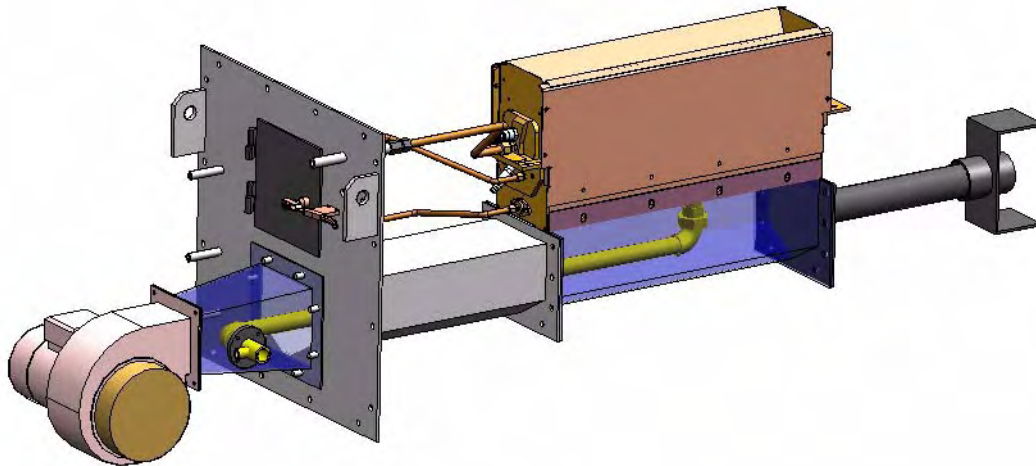

2 ft APX® burner of 300 kW for low temperature air heating in a spray booth. Slide-in-unit for easy in-duct installation. Including combustion air blower, main and pilot gas connection, gas and air test connections and electrical feed through for spark ignitor and flame rod.

Dimensions and weights

- 1) Combustion air inlet
- 2) Main gas inlet 1.1/2" NPT

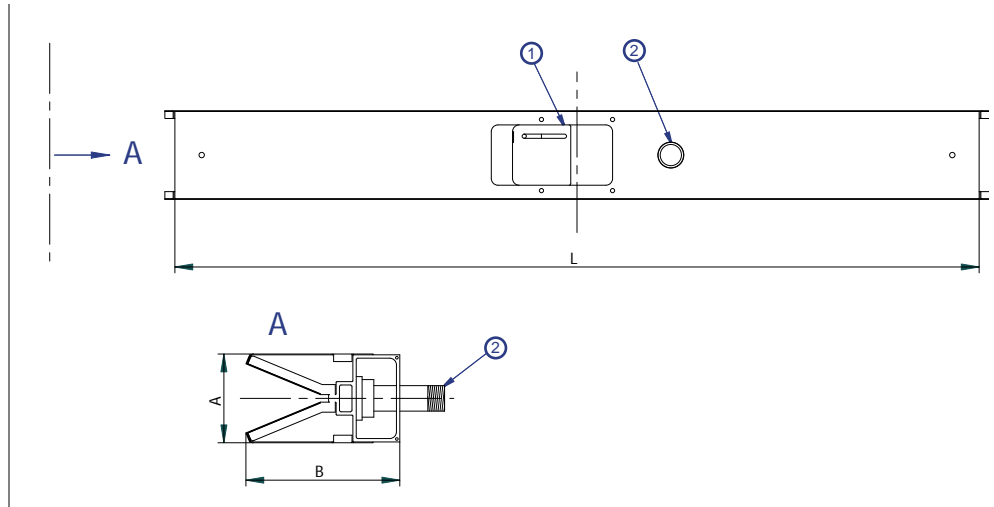

Dimensions in in. unless stated otherwise															
burner size (ft)	1	2	3	4	5	6	7	8	9	10	11	12	13	14	15
L	12	24	36	48	60	72	84	96	108	120	132	144	156	168	180
Weight (lbs)	13	26	42	55	68	81	95	108	123	137	150	163	176	192	205
A	6.6														
B	11.5														



Number and position of gas and air inlets depends on burner size. Refer to "Specifications of APX® burners" for additional details.

Typical emissions (burners only)

Thanks to the advanced mixing technology of the single-piece gas/air body, MAXON APX® burners combine excellent flexibility and turndown with very sharp emission levels on both CO and NO_x. Contact MAXON for more information.

Read "Specifications of APX® burners" for correct and complete information on APX® burners.

