

# KINEDIZER® LE

High capacity low NOx gas burners



- Field proven low emissions. State-of-the-art low NOx firing - adjustable for application flexibility
- Lower NOx and less excess air than standard KINEDIZER® burners
- Rugged design for oxidizers, process heaters, kilns, furnaces, dryers, waste incineration and other high temperature applications
- Available in a wide range of capacities, each with turndown as high as 20:1
- Burns natural gas, propane or other fuel gases
- Provides excellent stirring and mixing with its medium velocity exhaust
- Accepts preheated and vitiated combustion air

## Product description

The KINEDIZER® LE burner is a nozzle-mix, medium-velocity design. Using advanced mixing technology, the burner produces low emissions with very little excess air. Ruggedly built with a reinforced refractory block and steel burner body and nozzle, it burns natural gas, propane or other gaseous fuels. Combustion air is supplied with an external blower. Accurate air and fuel modulation can be accomplished by the MAXON MICRO-RATIO® valve or SMARTLINK® technology.

Combustion air can range from 21% down to 17% O<sub>2</sub> if preheated and from ambient temperature up to 660°F (max. 800°F) on request. Maximum chamber temperature is 2000°F .

Flame length with 30% excess air is 4 in/MBtu/h (with 5% excess air: 1 ft/MBtu/h ). Turndown up to 20:1.

Contact MAXON for correct application details.

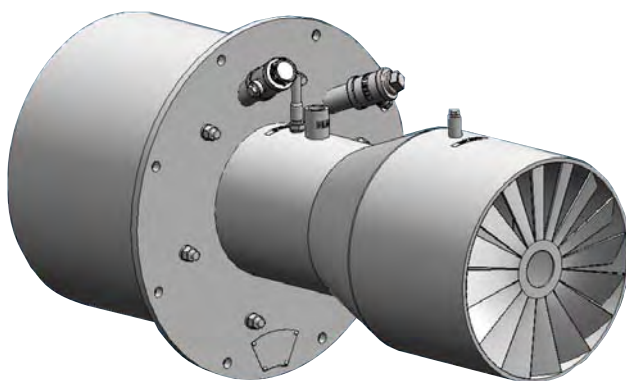

View of KINEDIZER® LE burner

## Available KINEDIZER® LE sizes

Typical burner data							
Fuel: natural gas at 60°F with 1000 Btu/ft <sup>3</sup> (st) HHV - sg = 0.6 [1]							
Combustion air: 60°F - 21% O <sub>2</sub> - 50% humidity - sg = 1.0 [1]							
Stated pressures are indicative. Actual pressures are a function of air humidity, altitude, type of fuel and gas quality.							
KINEDIZER® LE size		1-1/2"	3"	4"	6"	8"	10"
Maximum capacity @ n=1.3	MBtu/h	0.55	2.4	4.6	9.8	16	25
Air flow at maximum capacity	scfm	110	500	950	2000	3225	5000
Advised pilot capacity	MBtu/h	0.1	0.2	0.2	0.3	0.5	1.0
Combustion air pressure @ inlet [2]	"wc	28	32	32	32	32	32
Natural gas inlet pressure differential	"wc	55	52	42	64	40	75

[1] sg (specific gravity) = relative density to air (density air = 0.0763 lb/ft<sup>3</sup> (st))

[2] Combustion air pressure required at full capacity, relative to process. Add 5% safety margin + piping & control valve pressure drops for blower sizing.

## Applications

KINEDIZER® LE burners may be applied to a variety of applications for low to ultra-low emissions. The rugged design of the KINEDIZER® LE burner is ideal for oxidizers and incinerators, process heaters, kilns, furnaces, and other high temperature applications.

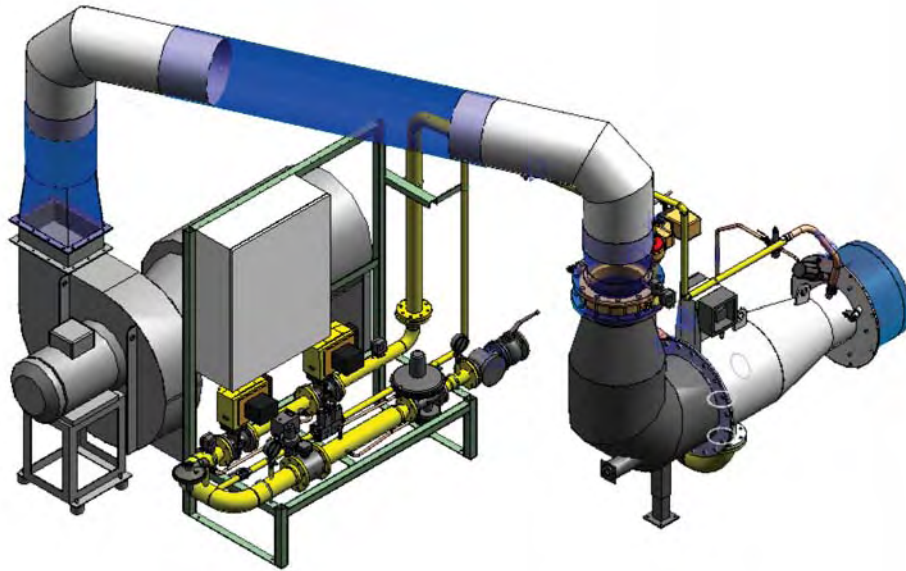

KINEDIZER® LE burner with pipe train, control panel and combustion air blower

## Dimensions and weights

- 1) Optional air inlet flange
- 2) 1/4" NPT gas test connection
- 3) Main gas inlet
- 4) Standard block or block with sleeve option

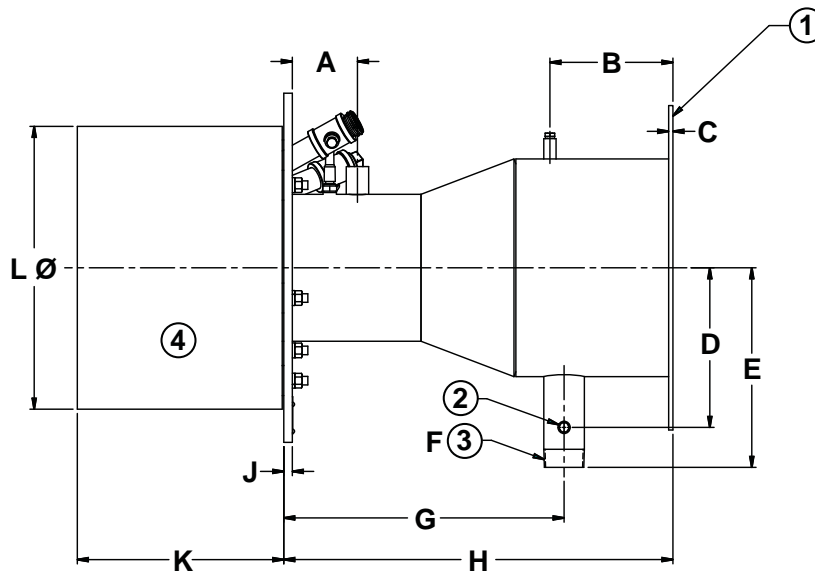

Dimensions in inches unless stated otherwise

Burner size	A	B	C	D	E	F Ø NPT	G	H	J	K	L Ø	Weight lbs
1-1/2"	2.0	1.97	0.25	3.6	4.6	1/2"	5.7	7.86	0.25	9.5	8.6	66
3"	2.99	3.12	0.25	4.69	6.25	1-1/4"	6.94	10.06	0.375	9.5	10.4	100
4"	2.31	3.84	0.25	5.94	7.5	1-1/2"	11.24	15.09	0.375	9.5	12.9	165
6"	3.3 84	5.0	0.25	7.81	9.38	1-1/2"	14.76	19.75	0.5	12.1	14.6	265
8"	3.81	7.2	0.25	9.35	11.69	2"	16.42	22.79	0.5	12.1	16.6	331
10"	3.81	7.2	0.25	11.97	14.31	2"	23.86	29.71	0.5	12.1	18.7	662

## Typical emissions

The KINEDIZER® LE burner is capable of low NO<sub>x</sub> when given excess air, typically 20-30% at high fire.

The same burner, when adjusted for on-ratio operation, will give low CO and high thermal efficiency. With flue gas recirculation, the emissions and efficiency can be further improved.

Read "Specifications of KINEDIZER® LE burners" for more detailed information on KINEDIZER® LE burners.