

# Ultrasonic flowmeters

**SITRANS FUE1010 IP65 NEMA 4X  
7ME3500**

Operating Instructions - January 2013



## SITRANS F

Answers for industry.

**SIEMENS**



# SIEMENS

## SITRANS F

### Ultrasonic Flowmeters FUE1010 IP65 NEMA 4X



#### Operating Instructions

<u>Introduction</u>	<b>1</b>
<u>Safety notes</u>	<b>2</b>
<u>Description</u>	<b>3</b>
<u>Installing/mounting</u>	<b>4</b>
<u>Connecting</u>	<b>5</b>
<u>Commissioning</u>	<b>6</b>
<u>Functions</u>	<b>7</b>
<u>Alarm, error, and system messages</u>	<b>8</b>
<u>Service and maintenance</u>	<b>9</b>
<u>Troubleshooting</u>	<b>10</b>
<u>Technical data</u>	<b>11</b>
<u>Appendix</u>	<b>A</b>
<u>Appendix</u>	<b>B</b>

## Legal information

### Warning notice system

This manual contains notices you have to observe in order to ensure your personal safety, as well as to prevent damage to property. The notices referring to your personal safety are highlighted in the manual by a safety alert symbol, notices referring only to property damage have no safety alert symbol. These notices shown below are graded according to the degree of danger.

 <b>DANGER</b>
indicates that death or severe personal injury <b>will</b> result if proper precautions are not taken.
 <b>WARNING</b>
indicates that death or severe personal injury <b>may</b> result if proper precautions are not taken.
 <b>CAUTION</b>
indicates that minor personal injury can result if proper precautions are not taken.
<b>NOTICE</b>
indicates that property damage can result if proper precautions are not taken.

If more than one degree of danger is present, the warning notice representing the highest degree of danger will be used. A notice warning of injury to persons with a safety alert symbol may also include a warning relating to property damage.

### Qualified Personnel

The product/system described in this documentation may be operated only by **personnel qualified** for the specific task in accordance with the relevant documentation, in particular its warning notices and safety instructions. Qualified personnel are those who, based on their training and experience, are capable of identifying risks and avoiding potential hazards when working with these products/systems.

### Proper use of Siemens products

Note the following:

 <b>WARNING</b>
Siemens products may only be used for the applications described in the catalog and in the relevant technical documentation. If products and components from other manufacturers are used, these must be recommended or approved by Siemens. Proper transport, storage, installation, assembly, commissioning, operation and maintenance are required to ensure that the products operate safely and without any problems. The permissible ambient conditions must be complied with. The information in the relevant documentation must be observed.

### Trademarks

All names identified by ® are registered trademarks of Siemens AG. The remaining trademarks in this publication may be trademarks whose use by third parties for their own purposes could violate the rights of the owner.

### Disclaimer of Liability

We have reviewed the contents of this publication to ensure consistency with the hardware and software described. Since variance cannot be precluded entirely, we cannot guarantee full consistency. However, the information in this publication is reviewed regularly and any necessary corrections are included in subsequent editions.



# Table of contents

<b>1</b>	<b>Introduction.....</b>	<b>9</b>
1.1	Preface.....	9
1.2	Items supplied.....	9
1.3	History.....	10
1.4	Further Information.....	10
<b>2</b>	<b>Safety notes.....</b>	<b>11</b>
2.1	General safety instructions.....	11
2.2	Warning Symbols.....	12
2.3	Laws and directives.....	12
2.4	Lithium batteries.....	13
2.5	Installation in hazardous area.....	14
2.6	Safety Notes.....	16
<b>3</b>	<b>Description.....</b>	<b>21</b>
3.1	FUE1010 features.....	21
3.2	NEMA 4X Energy Transmitter.....	21
3.3	Applications.....	22
3.4	Theory of Operation.....	23
<b>4</b>	<b>Installing/mounting.....</b>	<b>29</b>
4.1	Installation safety precautions.....	29
4.2	Determining a location.....	29
4.3	Use according to specifications.....	30
4.4	Application Guidelines.....	30
4.5	Mounting the Transmitter.....	31
<b>5</b>	<b>Connecting.....</b>	<b>33</b>
5.1	Safety notes for connecting.....	33
5.2	Transmitter Wiring.....	35
5.2.1	Connecting Power.....	35
5.2.2	Wiring Temperature Sensor to Transmitter.....	38
5.3	Navigating the Menu.....	43
5.4	Programming the Transmitter.....	45
5.5	Sensor Installation.....	50
5.5.1	Preliminary Installation Procedures.....	50

5.5.2	Sensor Identification and Selection.....	54
5.5.3	Reflect Mount.....	58
5.5.4	Direct Mount.....	61
5.5.5	1012T Mounting Tracks.....	65
5.5.6	Zero Flow Adjust Menu.....	74
5.6	Mounting Temperature Sensors.....	78
5.7	Sensor Wiring.....	80
<b>6</b>	<b>Commissioning.....</b>	<b>83</b>
6.1	General requirements.....	83
6.2	Empty Pipe Set.....	85
6.3	Installation Menus.....	87
<b>7</b>	<b>Functions.....</b>	<b>93</b>
7.1	Selecting Flow Units.....	93
7.2	Span Data.....	98
7.3	Logger Control.....	100
7.4	Operation Adjust Menu Settings.....	104
7.5	Setting Relays.....	107
7.6	Memory Control.....	109
7.7	Analog Out Setup.....	110
7.8	Analog Input Setup.....	113
7.9	Energy AnCal.....	117
7.10	Analog Output Trim.....	117
7.11	RTD Calibration.....	121
7.12	Reflexor.....	124
<b>8</b>	<b>Alarm, error, and system messages.....</b>	<b>137</b>
<b>9</b>	<b>Service and maintenance.....</b>	<b>139</b>
9.1	Maintenance.....	139
9.2	Technical support.....	139
9.3	Return procedures.....	140
9.4	Battery disposal.....	141
<b>10</b>	<b>Troubleshooting.....</b>	<b>143</b>
10.1	Troubleshooting.....	143
10.2	F4 Reset Procedure.....	146
10.3	Test Facilities Graph Screen.....	147
10.4	Site Setup Data.....	157
10.5	Force Transmit.....	161

<b>11</b>	<b>Technical data</b> .....	<b>165</b>
11.1	Technical Data .....	165
<b>A</b>	<b>Appendix</b> .....	<b>167</b>
A.1	Certificates .....	167
A.2	Ordering .....	167
A.3	I/O Connections and Wiring .....	167
A.4	RS-232 Connection.....	188
A.5	Flowrate Calibration and Calibration Tables.....	199
<b>B</b>	<b>Appendix</b> .....	<b>203</b>
B.1	Installation/Outline Drawings .....	203
	<b>Glossary</b> .....	<b>205</b>
	<b>Index</b> .....	<b>211</b>

**Tables**

Table 5- 1	TB3 and TB4 Wiring.....	41
Table 5- 2	Keypad Function Chart .....	43
Table 5- 3	Pipe Configuration Option List Definitions .....	49
Table 5- 4	Temperature Sensors .....	78
Table 7- 1	Totalizer Modes .....	94
Table 7- 2	Totalizer Controls (the "n" in <Fn> = channel number)* .....	97
Table 7- 3	Logger Control Menu Option List.....	101
Table 7- 4	Relay Option List.....	108
Table 7- 5	Memory Control Menu .....	109
Table 7- 6	Analog Outputs .....	110
Table 7- 7	Analog Out Setup Data Categories .....	110
Table 7- 8	Analog Out Trim Menu Structure .....	118
Table 7- 9	RTD Calibrate Menu Structure.....	122
Table 7- 10	Inline Metal and Plastic Pipe Cable Connections .....	127
Table 7- 11	Cursor Definitions .....	132
Table 7- 12	Diagnostic Data.....	134
Table 8- 1	Alarm Codes .....	137
Table 10- 1	Troubleshooting Tips .....	143
Table 10- 2	Description of Graph Screen Text Display Parameters.....	155
Table 10- 3	Hot Key Summary.....	156
Table 10- 4	Site Setup Menu Items.....	157

Table 11- 1	Performance Specifications .....	165
Table A- 1	Connection Diagrams and Part Numbers .....	167
Table A- 2	Input/Output Wiring (TB2) - 7ME39400AL00 and 7ME39400AL01 I/O Module (for 7ME3500 or 7ME3530 only) .....	168
Table A- 3	Input/Output Wiring (TB3) - 7ME39400AL00 and 7ME39400AL01 I/O Module .....	170
Table A- 4	Connection Diagrams and Part Numbers .....	171
Table A- 5	Input/Output Wiring (TB2) - 7ME39400AL03 and 7ME39400AL04 Expanded I/O Module .....	173
Table A- 6	Input/Output Wiring (TB3) - 7ME39400AL03 and 7ME39400AL04 Expanded I/O Module .....	174
Table A- 7	Input/Output Wiring (TB4) - 7ME39400AL03 and 7ME39400AL04 Expanded I/O Module .....	175
Table A- 8	Connection Diagrams and Part Numbers .....	176
Table A- 9	Input/Output Wiring (TB2) - 7ME39400AL04 Expanded I/O Module .....	178
Table A- 10	Open Collector User Resistor Recommendations .....	179
Table A- 11	Input/Output Wiring (TB3) - 7ME39400AL04 Expanded I/O Module .....	180
Table A- 12	Input/Output Wiring (TB4) - 7ME39400AL04 Expanded I/O Module .....	181
Table A- 13	Input/Output Wiring (TB3) - 7ME39406ML00 I/O Module (4-Channel) .....	182
Table A- 14	Connection Diagrams and Part Numbers .....	183
Table A- 15	Input/Output Wiring TB1 7ME39404SB00 - Analog Input Module (2 Chan/Dual Path) .....	184
Table A- 16	Input/Output Wiring TB2 7ME39404SB00 - Analog Input Module (2 Chan/Dual Path) .....	184
Table A- 17	Input/Output Wiring TB3 7ME39404SB00 - Analog Input Module (2 Chan/Dual Path) .....	184
Table A- 18	Input/Output Wiring TB4 7ME39404SB00 - Analog Input Module (2 Chan/Dual Path) .....	184
Table A- 19	Input/Output Wiring TB5 7ME39404SB00 - Analog Input Module (2 Chan/Dual Path) .....	185
Table A- 20	Connection Diagrams and Part Numbers .....	186
Table A- 21	Input/Output Wiring TB1 7ME39400SA00 - Analog Input Module .....	186
Table A- 22	Input/Output Wiring TB2 7ME39400SA00 - Analog Input Module .....	187
Table A- 23	Input/Output Wiring TB3 and TB4 7ME39400SA00 - Analog Input Module .....	187

## Figures

Figure 3-1	Typical Transmitter Label .....	22
Figure 3-2	NEMA 4X Transmitter Case .....	22
Figure 4-1	Pipe Mounting and Mounting Locations for Transmitter .....	32
Figure 5-1	Input Power (J10) Wiring .....	36
Figure 5-2	Analog Input Module Access .....	39
Figure 5-3	Single Channel Temperature Sensor Inputs .....	39
Figure 5-4	Dual Channel Temperature Sensor .....	41

Figure 5-5	KeyPad.....	43
Figure 5-6	Typical Installation Menu Screen.....	44
Figure 5-7	Reflect Mount (Pipe shown from above in 12 o'clock position).....	51
Figure 5-8	Direct Mount (Pipe shown from above in 12 o'clock position).....	52
Figure 5-9	Sensor Alignment (Horizontal Plane).....	53
Figure 5-10	Pipe Surface Preparation.....	54
Figure 5-11	Universal Sensor Label.....	55
Figure 5-12	Hi Precision Sensor Label.....	56
Figure 5-13	Reflect Mount with Mounting Frames and Spacer Bar.....	58
Figure 5-14	Sensor.....	60
Figure 5-15	Sensor Installation.....	60
Figure 5-16	Mylar Spacing Guide.....	61
Figure 5-17	Wrap Strap Under Pipe and Attach to Adjusting Screw.....	62
Figure 5-18	Wrapping the Mylar Spacing Guide around the pipe (End View).....	63
Figure 5-19	Finding the Halfway Distance.....	64
Figure 5-20	Aligning the Sensors for Direct Mode operation (End View).....	64
Figure 5-21	Reflect Mount with Model 1012TN Mounting Track (Side View).....	67
Figure 5-22	Direct Mount 180° opposed with Mounting Tracks.....	69
Figure 5-23	Wrapping the Mylar Spacing Guide around the pipe (End View).....	71
Figure 5-24	Finding the Halfway Distance.....	71
Figure 5-25	Track Rail Alignment.....	72
Figure 5-26	REF and Number Index Pin Locations.....	73
Figure 5-27	Clamp-on Temperature Sensor.....	79
Figure 5-28	Insert Temperature Sensor.....	80
Figure 5-29	Sensor Cable Connections.....	81
Figure 6-1	Final Setup.....	83
Figure 6-2	Measuring Flow.....	84
Figure 7-1	Sensor Mounting Examples.....	126
Figure 7-2	Adjacent Sensor Mounting.....	127
Figure 7-3	In-Line Sensor Mounting.....	128
Figure 7-4	Spectra Graph Display Screen.....	131
Figure 10-1	Test Facilities Graph Screen.....	148
Figure 10-2	Setting Digital Damping Factor.....	151
Figure 10-3	Setting the MinDamp Factor.....	152
Figure 10-4	Envelope Threshold Adjustment.....	154
Figure A-1	7ME39400AL00 and 7ME39400AL01 I/O Module.....	168

*Table of contents*

---

Figure A-2	7ME39400AL03 and 7ME39400AL04 Expanded I/O Module .....	172
Figure A-3	7ME39400AL04 Expanded I/O Module .....	177
Figure A-4	7ME39404SB00 Analog Input Module .....	183
Figure A-5	Temperature Sensor Inputs .....	185
Figure A-6	7ME39400SA00 - Analog Input Module.....	186
Figure A-7	1015CPC-N Serial Interface Cable .....	189

# Introduction

## 1.1 Preface

These instructions contain all the information you need for using the device.

The instructions are aimed at persons mechanically installing the device, connecting it electronically, configuring the parameters and commissioning it as well as service and maintenance engineers.

---

### Note

It is the responsibility of the customer that the instructions and directions provided in the manual are read, understood and followed by the relevant personnel before installing the device.

---

## 1.2 Items supplied

- SITRANS F Transmitter
- SITRANS F literature CD
- For additional items refer to your packing slip.

## Inspection

1. Check for mechanical damage due to possible improper handling during shipment. All claims for damage are to be made promptly to the shipper.
2. Make sure the scope of delivery, and the information on the type plate corresponds to the ordering information.

## 1.3 History

The contents of these instructions are regularly reviewed and corrections are included in subsequent editions. We welcome all suggestions for improvement.

The following table shows the most important changes in the documentation compared to each previous edition.

Edition	Remarks
09/2010	First Edition of Operating Instructions for SITRANS FUE1010 IP65 NEMA 4X energy flowmeter.
01/2013	Second Edition of Operating Instructions for SITRANS FUE1010 IP65 NEMA 4X energy flowmeter. This document replaces all previous instructions for use. The most important changes are as follows: <ul style="list-style-type: none"><li>• To use Si-Ware download the program at [<a href="http://s13.me/ns/cv">http://s13.me/ns/cv</a>]</li><li>• Expanded I/O Module Installation Wiring Diagram 1010N-7-7 has been updated to Revision 08.</li><li>• I/O Module Installation Wiring Diagram 1010N-2-7 has been updated to Revision 05.</li><li>• Analog Input Module Installation Drawing 1010N-5DS2-7 has been updated to Revision 06. Appendix I/O Connection and Wiring chapter has been updated.</li></ul>

## 1.4 Further Information

### Product information on the Internet

The Operating Instructions are available on the CD-ROM shipped with the device and on the Internet on the Siemens homepage, where further information on the range of SITRANS F flow meters may also be found: Product information on SITRANS F in the Internet (<http://www.siemens.com/sitransf>)

### Worldwide contact person

If you need more information or have particular problems not covered sufficiently by the operating instructions, please get in touch with your contact person. You can find contact information for your local contact person on the Internet: [www.siemens.com](http://www.siemens.com) Local contact person (<http://www.automation.siemens.com/partner>)



## Safety notes

### 2.1 General safety instructions

 <b>CAUTION</b>
Correct, reliable operation of the product requires proper transport, storage, positioning and assembly as well as careful operation and maintenance. Only qualified personnel should install or operate this instrument.

---









**Note**

Alterations to the product, including opening or improper repairs of the product, are not permitted.

If this requirement is not observed, the CE mark and the manufacturer's warranty will expire.

---

## 2.2 Warning Symbols

Symbol	Explanation
	Consult operating instructions
	Hot surface
	Dangerous electrical voltage
	Corrosive materials
	Toxic materials
	Isolate the device from power using a circuit-breaker
	Protect the device from impact otherwise loss of degree of protection
	Protective insulation; device in protection class II

## 2.3 Laws and directives

### General requirements

Installation of the equipment must comply with national regulations. For example, the National Electrical Codes.

## Instrument safety standards

The device has been tested at the factory, based on the safety requirements. In order to maintain this condition over the expected life of the device the requirements described in these Operating Instructions must be observed.

### NOTICE

#### Material compatibility

Siemens can provide assistance with the selection of sensor parts. However, the full responsibility for the selection rests with the customer and Siemens can take no responsibility for any failure due to material incompatibility.

## CE marked equipment

The CE-mark symbolizes the compliance of the device with the following Directives:

- EMC-Directive 2004/108/EC
- Low voltage Directive 2006/95/EC
- ATEX Directive 94/9/EC

## 2.4 Lithium batteries

Lithium batteries are primary power sources with high energy content designed to represent the highest possible degree of safety.

### WARNING

#### Potential hazard

Lithium batteries may present a potential hazard if they are abused electrically or mechanically. This is in most circumstances associated with the generation of excessive heat where internal pressure may cause the cell to rupture.

Thus the following basic precautions should be observed when handling and using lithium batteries:

- Do not short-circuit, recharge or connect with false polarity.
- Do not expose to temperature beyond the specified temperature range or incinerate the battery.
- Do not crush, puncture or open cells or disassemble battery packs.
- Do not weld or solder to the battery's body.
- Do not expose contents to water.

## 2.5 Installation in hazardous area

 <b>WARNING</b>
<b>Explosion Hazard</b> Equipment used in hazardous areas must be Ex-approved and marked accordingly. It is required that the special conditions for safe use provided in the manual and in the Ex certificate are followed!

### Hazardous area approvals

The device is approved for use in hazardous area and has the following approval:

- FM and CSA certified
- Class I, Division 1, Groups ABCD
- Class II, Division 1, Groups EFG
- ATEX

 <b>WARNING</b>
<b>Explosion Hazard</b> Devices without the correct hazardous area approval create dangerous environments. Make sure the hazardous area approval is suitable for the environment in which the device will be installed.



### Intrinsically safe data

 <b>WARNING</b>
<b>Explosion Hazard</b> User must install unit with Siemens drawings. With intrinsically safe circuits, use only certified meters appropriate for the transmitter. If a non-conforming supply unit is used, the "fail-safe" type of protection will no longer be effective and the approval certification will be invalid.

## Hazardous area safety requirements

It is required that:

- Electrical connections are in accordance with EN60079-14 (Installing Electrical Systems in Explosion Hazardous Areas).
- The protective cover over the power supply is properly installed. For intrinsically safe circuits the connection area can be opened.
- Appropriate cable connectors are used for the output circuits:
  - Intrinsically safe: blue
  - Non-intrinsically safe: black
- Sensor and transmitter are connected to the potential equalization. For intrinsically safe output circuits potential equalization must be maintained along the entire connection path.
- When protective earth (PE) is connected, no potential difference between the protective earth (PE) and the potential equalization (PA) can exist, even during a fault condition.

<p> <b>WARNING</b></p> <p><b>Explosion Hazard</b></p> <p><b>"Flameproof enclosure" type of protection</b></p> <p>Only open devices with type of protection "Flameproof enclosure" (e.g. FUT1010 NEMA 7) in hazardous areas when the power to the device is turned off, otherwise there is a risk of explosion.</p>
<p> <b>WARNING</b></p> <p><b>Explosion Hazard</b></p> <p><b>Laying Cables</b></p> <p>Cable for use in zone 1 and 2 must satisfy the requirements for having a proof voltage &lt; AC 500 V applied between the conductor/ground, conductor/shield and shield/ground.</p> <p>Connect the devices that are operated in hazardous areas as per the stipulations applicable in the country of operation, e.g. for Ex "d" and "nA", permanent cables must be laid.</p>
<p> <b>WARNING</b></p> <p><b>Explosion Hazard</b></p> <p><b>Devices with the common approval "Intrinsically safe" and "Flameproof"</b></p> <p>The following is applicable for devices with the common approval "Intrinsically safe" and "Flameproof" (Ex ia + Ex d): Before commissioning, make sure that the type of protection that is not suitable is permanently defaced on the nameplate to avoid improper use.</p> <p>If a non-conforming infeed is used, the "fail-safe" type of protection will no longer be effective.</p>

## 2.6 Safety Notes

### Safety Information for Hazardous Areas



**! DANGER**

**Explosion Hazard**

**Will Cause Death, Serious Injury or Property Damage.**

Restrict use and repair to qualified personnel.

**! DANGER**

**Explosion Hazard**

Death or severe personal injury and/or equipment and property damage will result if proper Hazardous (Classified) Locations installation precautions are not taken.

Restrict use and repair to qualified personnel.

**! DANGER**

**Explosion Hazard**

The use of unauthorized parts in the repair of the equipment, tampering by unqualified personnel, or operation with the cover open in a Hazardous (Classified) Location will result in dangerous conditions which will cause death, serious injury, and/or equipment and property damage.

Restrict use and repair to qualified personnel.

Follow all safety instructions contained or referenced herein.

**! DANGER**

**Explosion Hazard**

Death or severe personal injury and/or equipment and property damage will result due to improper installation or use of this equipment when located in a Hazardous (Classified) Location.

- Install as directed.
- Disconnect power source before servicing.
- Keep cover closed when equipment is operating.

**⚠ WARNING****Qualified personnel**

This flowmeter system may only be set up and used in conjunction with this document and the instructions on the electronic media provided. Installation, maintenance and operation of the flowmeter system may only be performed by qualified personnel. Within the context of this Document, qualified persons are defined as persons who have the skills and knowledge related to the construction and operation of the electrical equipment and installations and have received safety training to recognize and avoid the potentially explosive hazards involved.

**Qualified personnel possess the following qualifications**

1. Is trained and authorized to energize, de-energize, clear, ground and tag circuits and equipment in accordance with established safety practices.
2. Is trained in the proper care and use of protective equipment such as rubber gloves, hard hat, safety glasses or face shields, flash clothing, etc., in accordance with established safety practices.
3. Is trained in rendering first aid.

**Note**

This document does not purport to cover all details or variations in equipment, or to provide for every possible contingency to be met in connection with installation, operation or maintenance. Should further information be desired or should particular problems arise, which are not covered sufficiently for the purchaser's purposes, the matter should be referred to the local Siemens sales office ([www.automation.siemens.com/partner](http://www.automation.siemens.com/partner)). The contents of this Document shall not become part of or modify any prior or existing agreement, commitment or relationship. The sales contract contains the entire obligation of Siemens. The warranty contained in the contact between the parties is the sole warranty of Siemens. Any statements contained herein do not create new warranties or modify the existing warranty.

**Safety Information for Hazardous Areas****Note**

**Ratings under this heading apply to specific model families.**

Check Your Model Number: FUE1010, 7ME3500

**FM-CSA installation**

Read, understand and follow all safety instructions on the electronic media provided. This equipment is rated for use in hazardous (classified) locations as stated below and must be installed according to the 1010-304 installation drawing provided on the media. Failure to install the equipment in the prescribed manner will result in unsafe operation. Follow all local jurisdictional safety codes when operating this equipment. When properly installed the equipment meets the following FM – CSA ratings.

### Transmitter

- Intrinsically safe connections Class I and II, Division 1, Groups A, B, C, D, E, F and G;
- Nonincendive for Class I, Division 2, Groups A, B, C and D;
- Suitable for Class II, Division 2, Groups E, F and G outdoor (Type 4X), Class III (CSA only)
- Temperature code T5 at an ambient of 40°C



### Sensors

- Intrinsically safe Class I and II, Division 1, Groups A, B, C, D, E, F and G;
- Nonincendive for Class I, Division 2, Groups A, B, C and D;
- Suitable for Class II, Division 2, Groups E, F and G outdoor (Type 4X), Class III (CSA only)
- Temperature code T6 at an ambient of 40°C

### ATEX installation

Read, understand and follow all safety instruction on the electronic media provided. This equipment complies with Directive 94/9/EC and is rated for use in potentially explosive atmospheres. The equipment markings are shown and explained below. Equipment must be installed according to the 1010-389 installation drawing provided on the media. Failure to install the equipment in the prescribed manner will result in unsafe operation. Follow all regional safety laws when operating this equipment. When properly installed the equipment meets the following ATEX ratings as stated in EC-Type Examination Certificate KEMA03ATEX1134

### Transmitter Markings and Explanations

-  II (1) G [Ex ia] IIC – Transmitter located in the non-hazardous area with intrinsically safe circuits of category Ex ia, which can be connected to Category 1 Sensors
-  II 3 (1) G Ex nC [ia] IIC T5 – Category 3 Transmitter located in Zone 2 explosion atmosphere with intrinsically safe circuits of category Ex ia, which can be connected to Category 1 Sensors in Zone 0
- IP65 – Ingress protection against solid bodies, rating of dust-tight and against liquid, rating of water jets

### Sensor Markings and Explanations

-  II 1 G Ex ia IIC T5 – Category 1 Sensors located in Zone 0 explosive atmosphere with intrinsically safe circuits of category Ex ia for use in potentially explosive atmosphere containing gases
- IP65 – Ingress protection against solid bodies, rating of dust-tight and against liquid, rating of water jets



## Safety Information for Hazardous Areas

---

### **Note**

**Ratings under this heading apply to specific model families.**

Check Your Model Number: FUE1010, 7ME3500

---

### **FM-CSA installation**

Read, understand and follow all safety instruction on the electronic media provided. This equipment is rated for use in hazardous (classified) locations as stated below and must be installed according to the 1010-443 installation drawing provided on the media. Failure to install the equipment in the prescribed manner will result in unsafe operation. Follow all local jurisdictional safety codes when operating this equipment. When properly installed the equipment meets the following FM – CSA ratings:

#### **Transmitter**

- Explosionproof for Class I, Division 1, Groups B, C, D;
- Dust-ignitionproof for Class II, Division 1, Groups E, F and G
- Intrinsically safe connections for Class I and II, Division 1, Groups A, B, C, D, E, F and G;
- Nonincendive for Class I, Division 2, Groups A, B, C and D;
- Suitable for Class II, Division 2, Groups E, F and G outdoor (Type 4X), Class III (CSA only)

#### **Sensors**

- Intrinsically safe Class I and II, Division 1, Groups A, B, C, D, E, F and G;
- Nonincendive for Class I, Division 2, Groups A, B, C and D;
- Suitable for Class II, Division 2, Groups E, F and G outdoor (Type 4X), Class III (CSA only)
- Temperature code T6 at an ambient of 40°C

### **ATEX installation**

Read, understand and follow all safety instruction on the electronic media provided. This equipment is rated for use in explosive atmospheres as stated below and must be installed according to the 1010-464 installation drawing provided on the media. Failure to install the equipment in the prescribed manner will result in unsafe operation. Follow all regional safety laws when operating this equipment. When properly installed the equipment meets the following ATEX ratings as stated in EC-Type Examination Certificate KEMA03ATEX1134

### Transmitter Markings and Explanations

- $\text{Ex}$ II (1) G [Ex ia] IIC – Transmitter located in the non-hazardous area with intrinsically safe circuits of category Ex ia, which can be connected to Category 1 Sensors for use in potentially explosive atmosphere containing gases
- $\text{Ex}$ II 3 (1) G Ex nC [ia] IIC T5 (Tamb = 0° To + 60°C) – Category 3 Transmitter located in Zone 2 explosive atmosphere with intrinsically safe circuits of category Ex ia, which can be connected to Category 1 Sensors in Zone 0 for use in potentially explosive atmosphere containing gases
- $\text{Ex}$ II 2 (1) G Ex d [ia IIC] IIB T5 (Tamb = 0° To + 50°C) – Category 2 Transmitter located in Zone 1 explosive atmosphere with intrinsically safe circuits of category Ex ia, which can be connected to Category 1 Sensors for use in potentially explosive atmosphere containing gases
- $\text{Ex}$ II 2 (1) G Ex d [ia IIC] IIB+H2 T5 (Tamb = 0° To + 50°C) – Category 2 Transmitter located in Zone 1 explosive atmosphere with intrinsically safe circuits of category Ex ia, which can be connected to Category 1 Sensors for use in potentially explosive atmosphere containing gases
- IP66 – Ingress protection against solid bodies, rating of dust-tight and against liquid, rating of heavy seas

### Sensor Markings and Explanations

- $\text{Ex}$ II 1 G Ex ia IIC T5 – Category 1 Sensors located in Zone 0 explosive atmosphere with intrinsically safe circuits of category Ex ia for use in potentially explosive atmosphere containing gases
- IP65 – Ingress protection against solid bodies, rating of dust-tight and against liquid, rating of water jets

## Description

### 3.1 FUE1010 features

#### Description

The Siemens SITRANS FUE1010 IP65 (NEMA 4X) energy flow meters achieve highly accurate flow measurement owing to the WideBeam ultrasonic transit-time technology. The sensors are mounted on the outside of the pipe, preventing contact with the medium.

The sensor construction makes installation and commissioning of even the largest sizes very straight forward and easy. The sensors deliver true multi-parameter measurements i.e. volume flow, density and temperature.

---

#### Note

This operating Instructions manual applies to the following FUE1010 IP65 (NEMA 4X) operating systems: Version 3.02.00 and later and version 5.03.00 and later.

---

### 3.2 NEMA 4X Energy Transmitter

#### SITRANS FUE1010 Transmitters

The SITRANS FUE1010 IP65 NEMA 4X series transmitters are available in Dual Channel and Dual Path versions. The transmitters include a graphic display providing flow rate, diagnostics data and keypad interface to access on-screen software setup menus. Safety agency approved SITRANS FUE1010 series transmitters have hazardous area certification as indicated in the label examples below.

### SITRANS FUE1010 NEMA 4X Transmitter Labels

The transmitter label is located on the right side panel of the unit. The illustration shows a typical label but labels vary depending upon model and installation location.



Figure 3-1 Typical Transmitter Label

### SITRANS FUE1010 Model Numbers

The SITRANS FUE1010 IP65 NEMA 4X model number:

- 2 Channel / 2 Path - 7ME3500-2

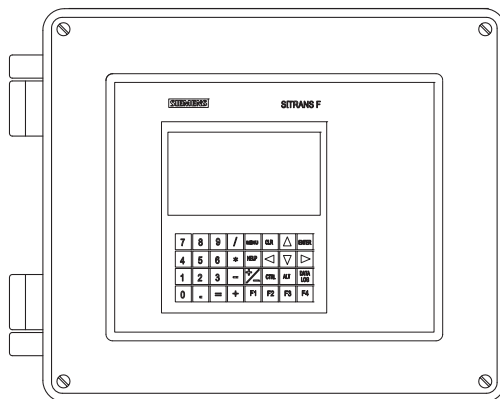

Figure 3-2 NEMA 4X Transmitter Case

## 3.3 Applications

### Measurement of liquids

SITRANS F flow meters are designed for measurement of a variety of liquids. The transmitters are multi-parameter devices offering accurate measurement of volume flow and temperature.

### Typical Applications

The typical applications of the flow meter for heat energy flow include:

- Chilled water
- Hot water
- Condenser water
- Lake source cooling
- Thermal storage
- Chemical feed flow

### Typical Industries Served

- HVAC (Hotels, Airports, Government, District heating)
- Power Generation (Nuclear, Fossil, and Hydro)
- Chemical Processing
- Food and Pharmaceutical
- Aircraft Avionics and Ground Support
- Water and Wastewater
- Aerospace
- Automobile Manufacturing
- Hydrocarbon Industries

## 3.4 Theory of Operation

The liquid flow meter relies on the MultiPulse transit-time. Two WideBeam ultrasonic sensors per measuring path, alternating as transmitter and receiver, are used to interrogate the liquid flowing within the metering section. The resulting time of arrival for each direction of transmit (upstream and downstream) is then measured using a highly accurate and stable digital signal processing method.

Using this detection scheme, the flow meter is capable of resolving the relative transit-time difference ( $\Delta T$ ) to within  $\pm 100$  psec. Considering typical liquid flow transit-time differences ranging from  $1 \times 10^4$  to  $1 \times 10^6$  psec, the flow meter is capable of providing an exceptional turn-down ratio. The flow meter also incorporates a correlation technique which enables the system to detect very high flow velocities with the same high degree of resolution. The ultrasonic sensors are designed with sufficient beam divergence characteristics to insure that the receive sensors will always have sufficient signal to maintain operation under conditions of high beam blowing, a condition that occurs under very high flow velocities where the path of the ultrasonic beam is actually blown past the receivable area of the sensors.

With accurate signal arrival time available, the flow meter can compute the raw flow velocity from the measured upstream and downstream transit times.

3.4 Theory of Operation

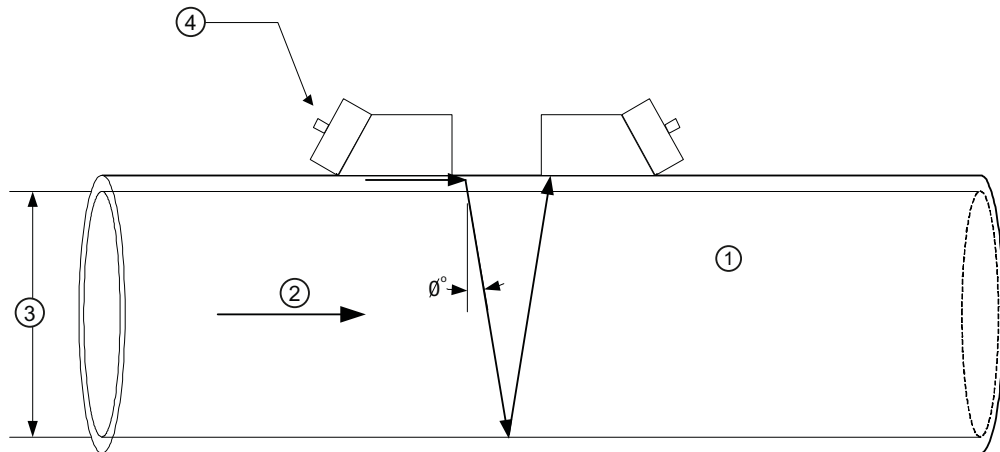

- ① Velocity of Sound
- ② Flow Vector
- ③ Pipe ID
- ④ Wide Beam Sensors

$$\theta = \sin^{-1} (VOS / V_{\text{phase}})$$

Where:

VOS = Velocity of sound in liquid

V<sub>phase</sub> = Phase velocity of sensor

ID = Pipe inside diameter

T<sub>L</sub> = Transit time in liquid

DT = Measured Transit-Time difference

V<sub>F</sub> = Flow Velocity

$$T_L = 2 * ID / (VOS * \cos \theta)$$

$$V_F = V_{\text{phase}} * DT / (2 * T_L)$$

**Flow Profile Compensation**

The flow equation shown above is only valid for "plug" flow, where the flow velocity is uniform across the entire cross-section of the pipe. Frictional forces between the fluid and the pipe wall cause the flow velocity to be nearly zero at the pipe wall and peaked toward the center of the pipe (as shown in the diagram below).

The acoustic beam traverses the center of the pipe and therefore must account for the influence that flow profile has on the line integration through a round pipe. The shape of this flow profile (for fully developed flow) is defined by the Reynolds number.

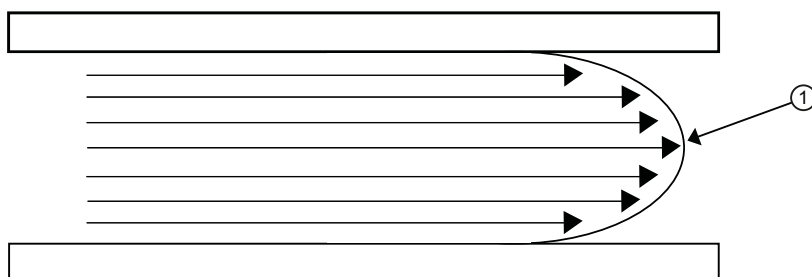

- ① Fluid velocity near the axis of the flow stream tends to be greater.

The Reynolds number is then computed as follows:

$$Rn = \frac{645 * \text{Pipe ID} * V_F}{\text{Viscosity}}$$

where:

viscosity = cS = cP/density

Pipe ID = inches

$V_F$  = inches/sec

cS = kinematic viscosity

cP = absolute viscosity

The flow meter then uses this computation of Reynolds number to compensate the raw flow velocity for conditions of laminar or turbulent flow profile as defined by an internal Reynolds compensation table. The flow meter then converts the compensated flow velocity to volumetric flow rate.

$$\text{Rate} = V_F * \text{Comp}(Rn) * \text{Pipe area}$$

## Flow meter Types

The meter automatically conditions Installation Menu choices to suit the selected meter type. The following paragraphs introduce the available flow meter types that include:

- 2-Channel
- 2-Path
- Channel 1+2
- Channel 1-2
- Reflexor

2-Channel

Dual Channel provides two independent measurement channels that operate simultaneously. Depending on the specific model, Dual Channel supports: Clamp-on Transit-time, In-line Transit-time and Reflexor.

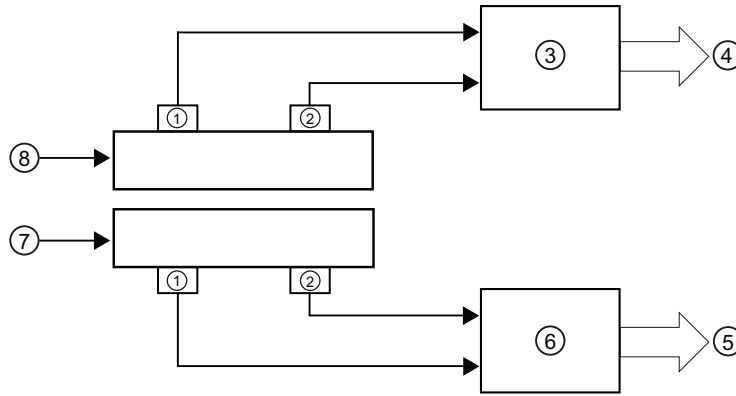

- |                        |                        |
|------------------------|------------------------|
| ① Upstream Sensors     | ⑤ Pipe B Output Flow   |
| ② Downstream Sensors   | ⑥ Channel 2 for Pipe B |
| ③ Channel 1 for Pipe A | ⑦ Pipe B               |
| ④ Pipe A Output Flow   | ⑧ Pipe A               |

2-Path

2-Path flow meters use two measurement channels to achieve a single output via a "virtual" third channel. The resultant data is the average of the two channels. Only clamp-on or in-line transit-time operation is allowed. Benefits include highest available precision and enhanced immunity to distorted flow profile conditions.

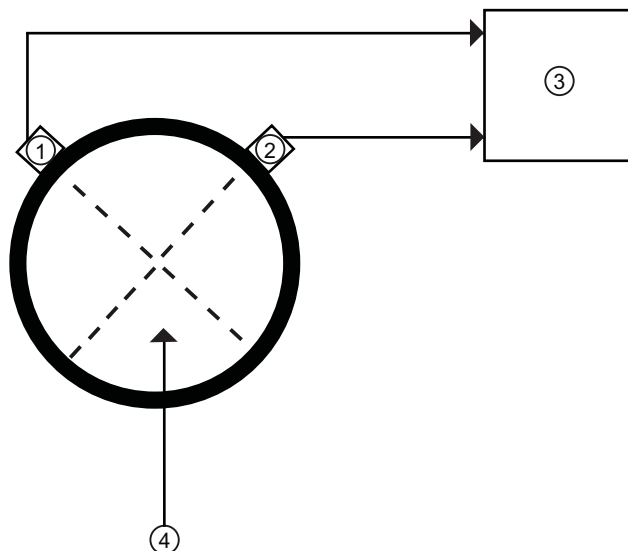

- |                 |                                  |
|-----------------|----------------------------------|
| ① Sensor Path 1 | ③ Average= (Path 1 + Path 2) / 2 |
| ② Sensor Path 2 | ④ Pipe (front view)              |



## Channel 1+2 and Channel 1-2

Arithmetic operation produces data output via a virtual Channel 3, proportional to the sum or difference of the liquid and energy flow of two independent pipes. This requires setting the two channels to operate independently. Only clamp-on or in-line transit-time operation is supported.

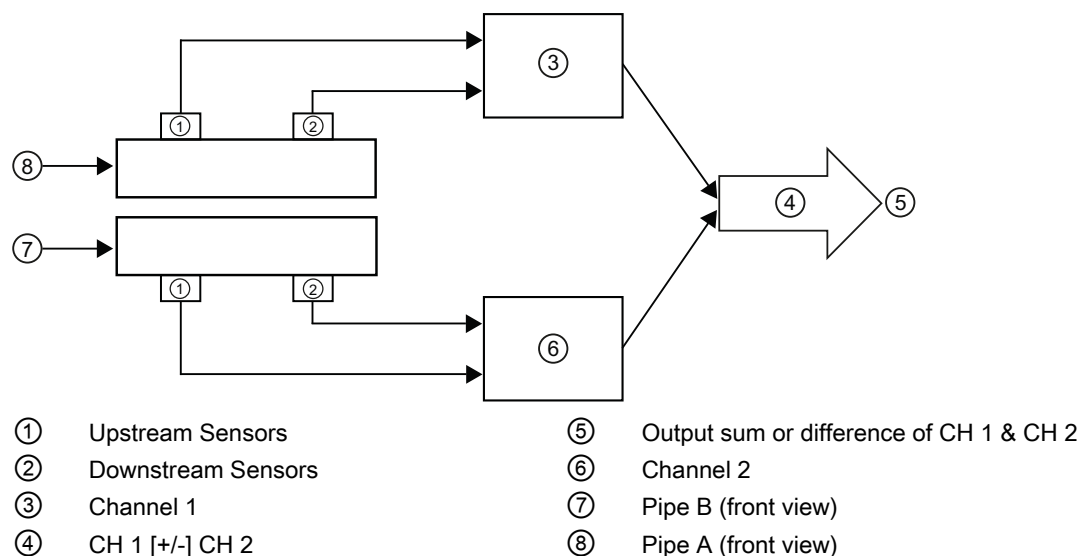

Channel 1+2 produces a data output via a virtual Channel 3, proportional to the sum of the liquid and energy flow of two independent pipes. You have to set-up two channels independently. Only clamp-on or in-line transit-time operation is supported.

Channel 1-2 produces a data output via a virtual Channel 3, proportional to the difference of the liquid and energy flow of two independent pipes. You have to set-up two channels independently. Only clamp-on or in-line transit-time operation is supported.

## WideBeam Transmission

As shown in the figure above, an ultrasonic sensor induces an axial sonic beam within the wall of the pipe. These vibrations spread along the pipe wall and then enter the liquid in the form of a Wide Beam wave front traveling at an angle to the main pipe axis. The wide beam "rains" over the receiving sensor. The wide coverage of the receiver is necessary because the angle of the sonic beam is related to the liquid's sonic propagation velocity by Snell's Law.

$$\text{Beam Angle} = \text{Arc Sine} \left( \frac{\text{Liquid Sonic Propagation Velocity}}{\text{Transducer Phase Velocity}} \right)$$

According to this formula, it can be stated that as the liquid sonic propagation velocity changes so will the angle between the sonic beam and the flow stream.

Therefore, a significant liquid sonic velocity shift could deflect a "narrow" beam transmission away from the receiving sensors entirely. The upstream vs. downstream transit-time difference will also be affected by the changing (or refracting) beam angle. This makes it necessary for flow meter systems to continuously compute this angle, since it is subject to varying degrees of refraction. The flow meter derives the angle by knowing the fixed position of the sensors, the dimensions of the pipe and the measured transit-time.

### Flow Calibration Factor

Normally, the flow stream is parallel to the axis of the pipe. On this basis, the calibration factor of a clamp-on ultrasonic flow meter is proportional to the cosine of the beam angle relative to the pipe axis. However, this reveals that if the angle of flow stream is not in line with the pipe axis, the flow calibration factor could be compromised. This most often occurs when the sensors mounting location is within close proximity of a bend or other pipe obstruction.

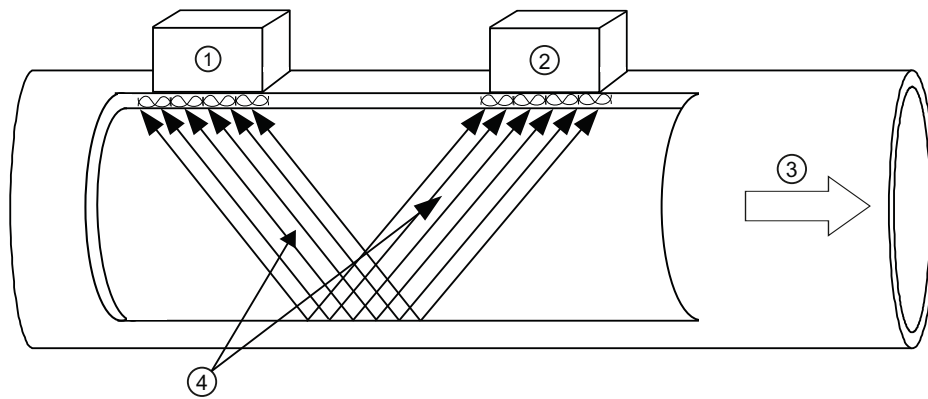

- ① Upstream Sensor
- ② Downstream Sensor
- ③ Flow Direction
- ④ Wide Beam transmissions exchanged between the Upstream and Downstream sensors

Reflect mounting automatically corrects for non-axial flow or cross flow since the 2 vectors in a reflected beam are affected in opposite directions, such that the individual cross flow errors cancel each other.

## Installing/mounting

### 4.1 Installation safety precautions

 **WARNING**

In applications with working pressures/media that can be dangerous to people, surroundings, equipment or others in case of pipe fracture, we recommend that special precautions such as special placement, shielding or installation of a security guard or a security valve are taken when the sensor is mounted.

- Ensure that stresses and loading caused by e.g. earthquakes, traffic, high winds and fire damage if appropriate are taken into account during installation.
- Ensure that the flowmeter is installed such that it does not act as a focus for pipeline stresses. External loadings are not taken into account in the flowmeter design.
- Provide adequate protection to minimise any risk of contact with hot surfaces.

 **WARNING**

Prevent personal injuries by assuring that operation below pressure guards cannot take place, if working with vacuum or fluids boiling readily.

### 4.2 Determining a location

 **WARNING**

**Electrical Shock Hazard**

May cause death or serious personal injury.

Disconnect power before working on this product.

#### Upstream / Downstream

- Avoid long drop lines downstream from the sensor to prevent the meter pipe from draining.
- Avoid installing the sensor upstream of a free discharge in a drop line where possible.

### 4.3 Use according to specifications

#### Sensor Location in piping system

The optimum location in the system depends on the application

- For liquid applications the presence of excessive gas or air bubbles in the fluid may result in erroneous measurements. Therefore, it is preferred not to install the sensor at the highest point in the system, where gas / air bubbles will be trapped. For liquids it is advantageous to install the sensor in low pipeline sections, at the bottom of a U-section in the pipeline.

### 4.3 Use according to specifications

"Use according to specifications" covers:

- Use within technical limits.
- Consideration of liquid specifications and references.
- Consideration of specifications as to installation, commissioning and maintenance.

Do NOT:

- Use the sensors as a footboard for installation purposes.
- Change the flow meter in any way. For e.g. decomposition of material in connection with processing, welding and use of accessories and spare parts not approved by Siemens.

---

#### Note

If the flowmeter is not used according to the specifications, the manufacturer cannot be held responsible for any resulting damage.

---

### 4.4 Application Guidelines

#### Basic Requirements

- Determine pipe material and dimensions.
- Avoid vertical pipes flowing in a downward direction.
- Avoid installation of sensors on the top and bottom of horizontal pipes, if possible.
- Select a location with the longest straight run of pipe.
- Identify upstream piping configuration (elbow, reducer, etc.).
- Pipe surface should be smooth and, if necessary, free of paint.
- Avoid pressure reduction components upstream.

- Avoid mounting on or near weld seams.
- Pipe must be full to achieve proper operation.

## 4.5 Mounting the Transmitter

 <b>WARNING</b>
<b>Hazardous Voltage</b> May cause death or serious personal injury. Disconnect power before working on this product.

### Wall Mounting

The transmitter can be mounted on any wall surface including wood, metal or concrete. Use the appropriate bolts and screws as needed for your mounting application and adhere to local codes. (See figure below for mounting bracket locations.)

### Pipe Mounting

For installation on 2-inch (6 cm) mounting pipe use Pipe Mount Kit CQO:1012NMB-1 (optional - see catalog). See figure below.

---

#### **Note**

Pipe mounting kit CQO:1012NMB-1 is not available for IP66 NEMA 7 enclosures.

---

4.5 Mounting the Transmitter

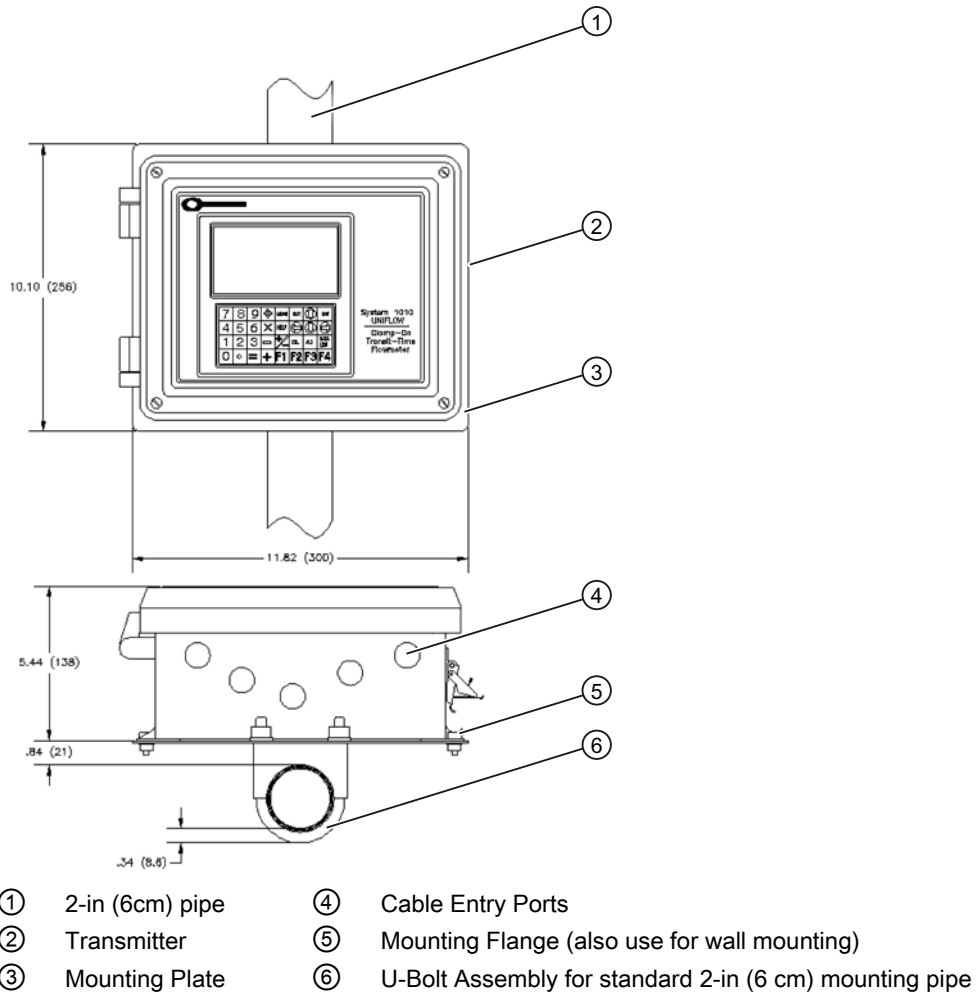

Figure 4-1 Pipe Mounting and Mounting Locations for Transmitter

**Note**

Use conduit fittings or cable glands on all cables.

**NOTICE**

**Weather Seal Malfunctions**

Incorrect installation of weather seals may result in failure to meet to IP65 standards and damage to the equipment.

Install weather tight seals at all unused holes using proper cable conduit and close additional holes to IP65 standards.

# Connecting

## 5.1 Safety notes for connecting

### Use in hazardous locations

 <b>DANGER</b>
<b>Explosion Hazard</b>
Death or severe personal injury and/or equipment and property damage will result if proper Hazardous (Classified) Locations installation precautions are not taken.
Restrict use and repair to qualified personnel. Only qualified personnel may carry out work on the electrical connections.

Before opening the terminal box check that:

- No explosion hazard exists
- Local safety codes and policy requirements have been followed
- All connection leads are potential free

<p><b>! DANGER</b></p> <p><b>Explosion Hazard</b></p> <p><b>"Flameproof enclosure" type of protection</b></p> <p>Only open devices with type of protection "Flameproof enclosure" (e.g. FUT1010 NEMA 7) in hazardous areas when the power to the device is turned off, otherwise there is a risk of explosion.</p>
<p><b>! DANGER</b></p> <p><b>Explosion Hazard</b></p> <p><b>Hazardous areas</b></p> <p>Observe the type examination certificates or the test certifications applicable in your country if you use transmitters as category 1/2 equipment, otherwise there is a risk of explosion.</p>
<p><b>! DANGER</b></p> <p><b>Explosion Hazard</b></p> <p><b>Intrinsically safe circuits</b></p> <p>If a non-conforming supply unit is used, the "fail-safe" type of protection will no longer be effective and the approval certification will be invalid, otherwise there is a risk of explosion.</p> <p>With intrinsically safe circuits, use only certified meters appropriate for the transmitter.</p>
<p><b>! DANGER</b></p> <p><b>Explosion Hazard</b></p> <p><b>Laying Cables</b></p> <p>Cable for use in zone 1 and 2 must satisfy the requirements for having a proof voltage &lt; AC 500 V applied between the conductor/ground, conductor/shield and shield/ground, otherwise there is a risk of explosion.</p> <p>Connect the devices that are operated in hazardous areas as per the stipulations applicable in the country of operation, e.g. for Ex "d" and "nA", permanent cables must be laid.</p>
<p><b>! DANGER</b></p> <p><b>Explosion Hazard</b></p> <p><b>Devices with the common approval "Intrinsically safe" and "Flameproof"</b></p> <p>The following is applicable for devices with the common approval "Intrinsically safe" and "Flameproof" (Ex ia + Ex d): Before commissioning, make sure that the type of protection that is not suitable is permanently defaced on the nameplate to avoid improper use, otherwise there is a risk of explosion.</p> <p>If a non-conforming infeed is used, the "fail-safe" type of protection will no longer be effective.</p>



 **WARNING**

**Electrical Voltage Hazard**

Incorrect device connections may result in death or severe personal injury and/or equipment and property damage.

Only commission the device after the device has been properly connected and, if required, closed.

## 5.2 Transmitter Wiring

### 5.2.1 Connecting Power

---

**Note**

If the transmitter is not already mounted and cabling has not been run, proceed to Mounting the Transmitter (Page 31) before connecting power.

---

 **DANGER**

**Electrical Shock Hazard**

Contact with exposed wiring will lead to fire, electric shock, or serious personal injury.

Turn off main power before installing AC connections to the transmitter.

1. Open the transmitter top cover by releasing the cover latch (for IP66 NEMA 7, remove bolts).
2. Unscrew the two power supply access cover fasteners and remove access cover.
3. Locate power supply connector J10. Using a flat blade screwdriver, remove plug from connector J10. Set aside.

5.2 Transmitter Wiring

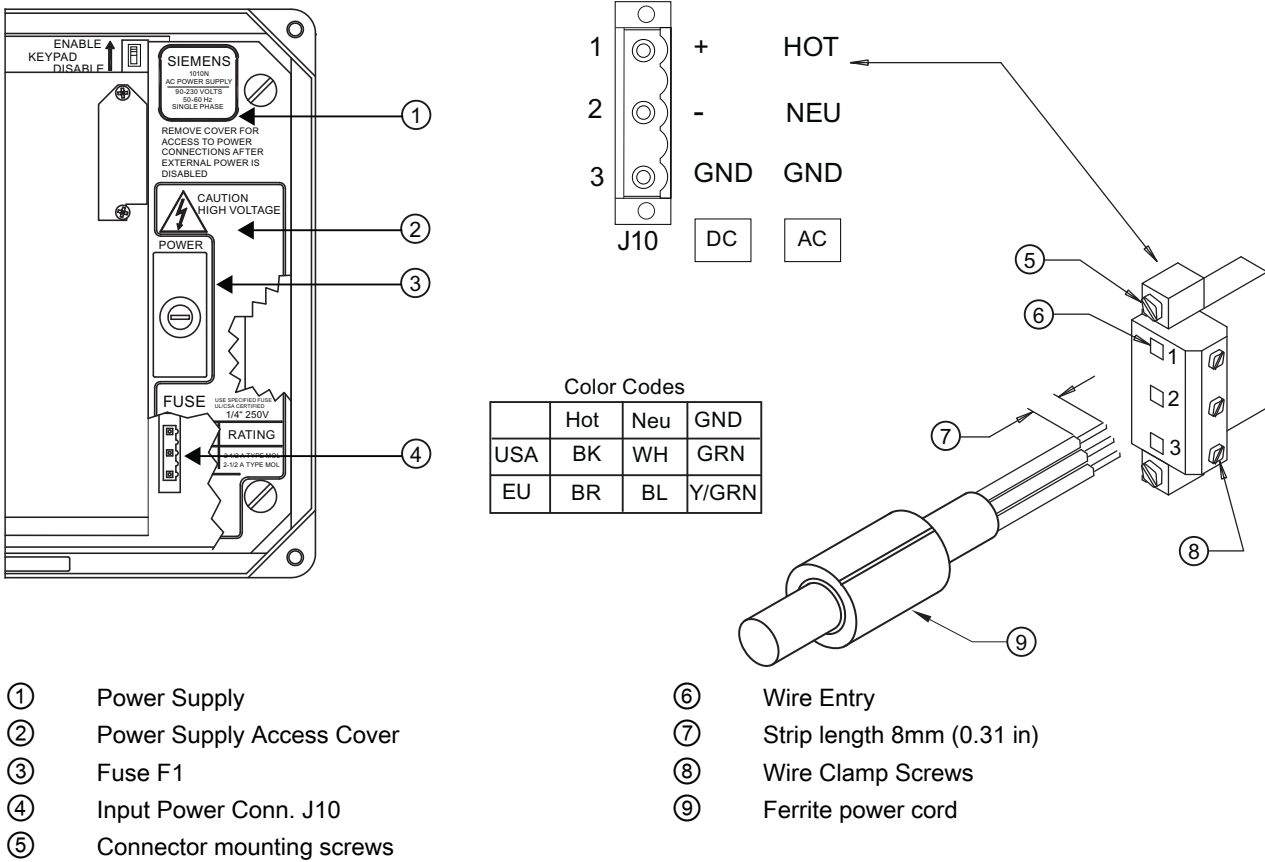

Figure 5-1 Input Power (J10) Wiring

4. Pull the desired length of input power wires through a cable gland and into transmitter case.
5. Wire input power connector for AC or DC power depending on power supply provided.

**Note**

Dress cables and make sure cable length is not excessive as to impede proper replacement of access cover.

6. Insert wires into wire entry holes and secure by tightening wire clamp screws (see figure above).

**Note**

Power Supply connector wires should be stripped AWG 12 - 18 stranded wire or solid conductors.

7. Plug input power plug into connector J10 and secure using two captive connector mounting screws.

8. Replace access cover. Make sure Keypad Enable switch is in the "Enable" position (see below).

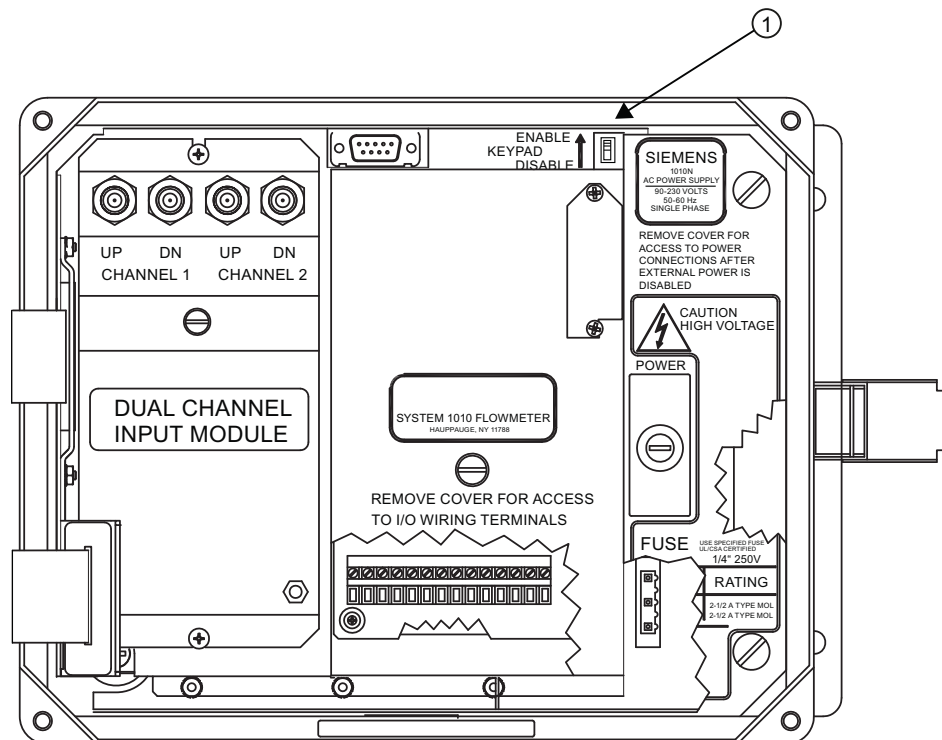

① Keypad Enable Switch

9. If installing a Temperature Sensor board, go to Wiring Temperature Sensor to Transmitter (Page 38). If not, go to step 10.

<b>⚠ CAUTION</b>
<b>Power Supply Damage</b>
Improper power connections will damage power supply.
Ensure that all AC or DC power supply connections are properly connected to the appropriate power source (100-250 VAC @ 50/60 Hz or 9-36 VDC).

<b>⚠ WARNING</b>
<b>Electrical Shock Hazard</b>
Certain parts inside the device carry dangerous high voltage and contact may lead to fire, electric shock, or serious personal injury.
The transmitter must be grounded and the top cover closed before applying power to the device.

10. Connect the power cables to the appropriate power source (100-240 VAC @ 50/60 Hz or 9-36 VDC). Close top cover.
11. Apply power.

12. Within 10 seconds of power-up the main display will become active and a typical Siemens graphic will appear. The screen also identifies the software version of the unit as shown below.



① Software Version (xx.xx.xx)

13. Press the <MENU> key and the Main Menu will appear. (Language selection is not on Version 3 op system.)

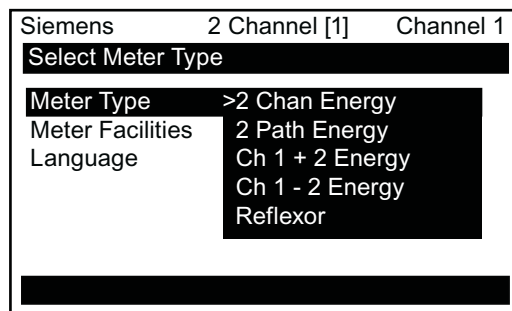

## 5.2.2 Wiring Temperature Sensor to Transmitter

### Wiring Temperature Sensor to Transmitter

**⚠ DANGER**

**Hazardous Live Voltage**

Death or severe personal injury will result if proper precautions are not taken

Set transmitter and instrumentation power to OFF when inserting or removing the Analog Input Module or when making connections to TB1, TB2, TB3 and TB4.

1. Disconnect power to the transmitter,
2. Open the transmitter top cover by releasing the cover latch.
3. Loosen the captive thumbscrew securing the Access Cover and remove Access Cover.
4. Using a flat-blade screwdriver, remove four captive screws securing the I/O board. Remove board and set it aside.

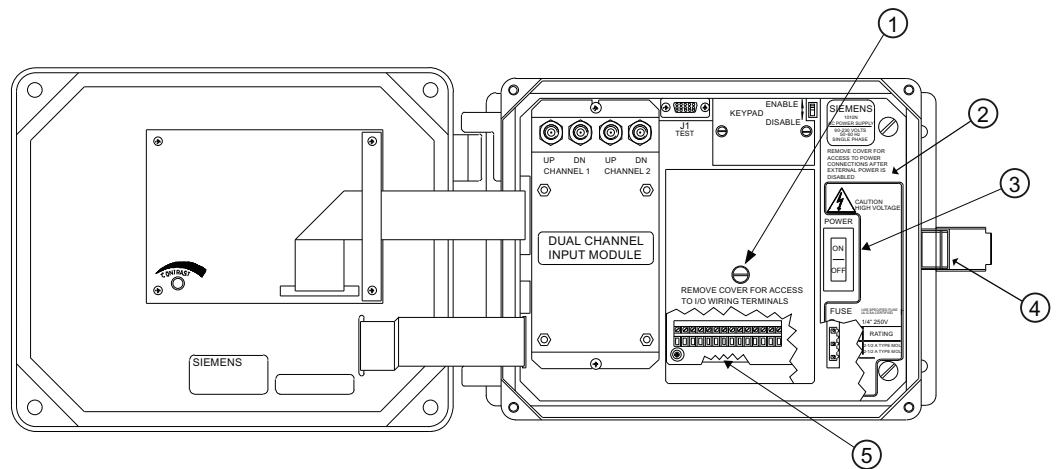

- ① Access Cover Screw
- ② Transmitter
- ③ Power Switch
- ④ Latch
- ⑤ Access to Analog Input Module

Figure 5-2 Analog Input Module Access

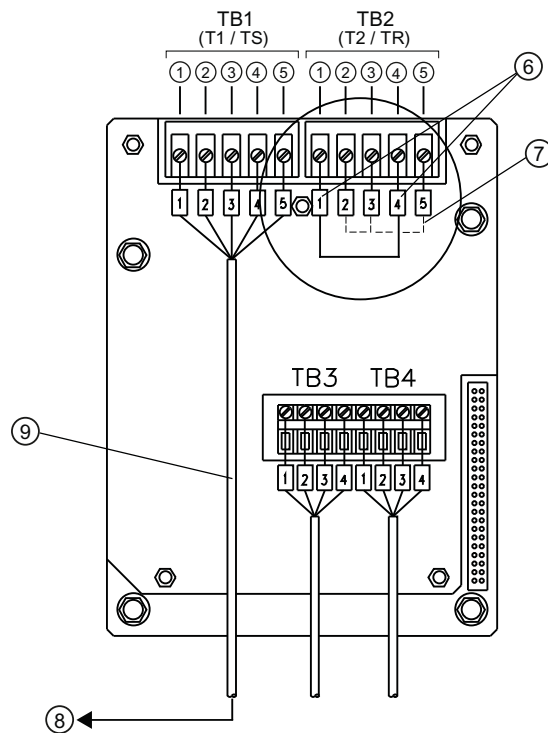

- ① Black
- ② Orange
- ③ Brown
- ④ Red
- ⑤ Blue
- ⑥ Short Terminals 1 and 4 (For FUE1010-TB2 is used for another Temperature sensor.)
- ⑦ Ground Terminals 2 and 3 to Terminal 5
- ⑧ To Sensor
- ⑨ 7ME39600CR (992EC) Series Cable

Figure 5-3 Single Channel Temperature Sensor Inputs

### Wiring Temperature Sensor Board

1. Using a flat-blade screwdriver, loosen Terminal Block TB1 and TB2 screws.
2. Wire the RTD liquid 992EC temperature cable as shown in the table below:

992EC Series Cable	Terminal TB1
Wire #1 (Black)	To TB1--1
Wire #2 (Orange)	To TB1--2
Wire #3 (Brown)	To TB1--3
Wire #4 (Red)	To TB1--4
Wire #5 GND/SHLD (Blue)	*To TB1--5

---

**Note**

\*For cathodically protected pipes, do not attach blue #5 wire at RTD end of cable.

---

3. For single channel use, wire TB2 as shown in figure above.
4. For dual channel use, connect Channel 2 temperature sensor to TB2.
5. Replace I/O Board and secure with four captive screws paying careful attention to pin alignment.
6. Replace Access Cover and finger tighten captive thumbscrew.
7. Connect power cables to the appropriate power source (90-240 VAC @ 50-60 Hz or 9-36 VDC). Close cover

---

**Note**

TB3 and TB4 are also active analog inputs. See wiring table below.

---

### Supply and Return Connections

Terminals for the supply and return sensor connections are located on the Analog Input Module as previously shown. For other terminal locations on Single Channel and Dual Channel units, refer to drawings 1010N-5-7 or 1010N-5D-7, respectively. For terminal locations on Multi-Channel units, refer to drawing 1010N-8M-7.

### Notes on Clamp-on RTD Installation

The Clamp-On RTD sensors of the flow meter are extremely sensitive and precise. Their contribution to the performance of your meter is every bit as important as that of the liquid flow sensors. Please consult the installation drawings in Appendix B (Page 203) for details on physical installation and wiring of the RTDs.

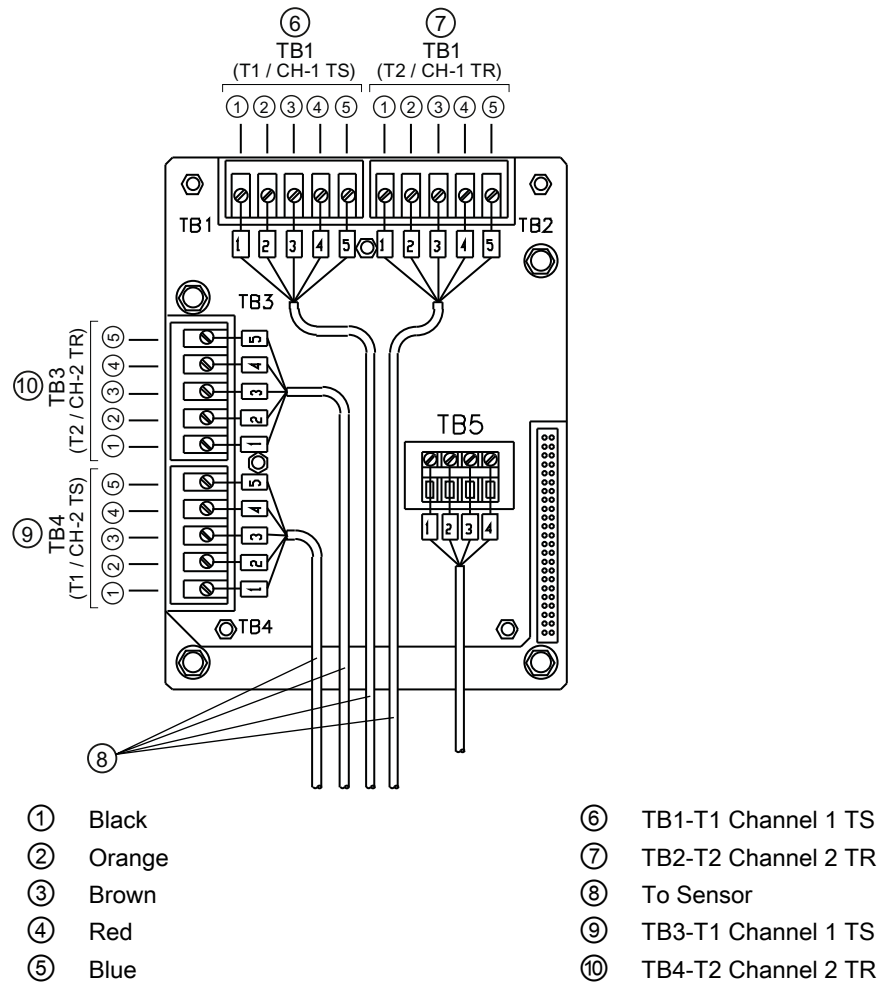

Figure 5-4 Dual Channel Temperature Sensor

Table 5- 1 TB3 and TB4 Wiring

Pin	TB3 Function	TB4 Function	Use	Description	Behavior	Load	Wiring
1	AUX. 1 IN	AUX. 3 IN	lin1 Input	Analog current input referenced to meter ground.	4 to 20mA	200Ω	1000 ft. Max w/o factory approval
2	AUX. 1 COM	AUX. 3 COM	lin1 Common				
3	AUX. 2 IN	AUX. 4 IN	lin2 Input				
4	AUX. 2 COM	AUX. 4 COM	lin2 Common				

In order to produce the best possible tracking of the true liquid temperature difference, try to make your installation conform to the notes on the installation drawing and the following:

- Prepare the pipe surface by removing paint to expose bare metal and smoothing any remaining rough spots.
- Use the thermal couplant (CC#117) between the face of the RTD element and the pipe surface to improve the conductivity of the metal-to-metal contact.
- Keep the RTDs out of direct sunlight or other non-pipe sources of heat or cold that may affect their temperature sensing. The foam insulator that is supplied helps in this regard, but consider using additional pipe insulation for all installations exposed to extreme ambient conditions. Consider mounting the RTDs under the pipes in order to keep them out of direct sunlight.
- In installations where the RTD elements are exposed to harsh conditions such as condensation, salt spray, etc., use C110 couplant to coat the connection between the cable and the RTD sensor. Consult drawing 991TN-7 for details.

### Paralleling RTD Inputs for Dual Channel Energy Measurement

To measure liquid flow in the same pipe twice (e.g. at the supply and return location of the line) but not redundantly, you have to measure the temperature. The following information may be helpful:

- Connect terminal #2 of terminal blocks TB1 and TB3 together and terminal #3 of TB1 and TB3. You can use any available hookup wire to do this. By doing this, you are not shorting terminals 2 and 3; just interconnecting 2/2 and 3/3 of each terminal block.
- Connect terminal #2 terminal blocks of TB2 and TB4 as well as Terminal #3 of TB2 and TB4. This hookup will result in the same temperature being reported for Tr and Ts for channels 1 and 2 of the meter. It probably is a good idea to check the temperature to ensure that they do indeed match. Of course, Td will be similarly identical. These temperatures can be checked in the [Diagnostics] / [Energy Data] menu.
- Be sure to accurately indicate where the flow is being measured in the [Location] item of the menu; either supply or return.

### Dual Path Models

Notes on Analog Input Modules:

- All units use T1 to report liquid temperature.
- The Analog Input of temperature takes priority over the built-in RTD (Resistive Temperature Device) measurement of temperature.



## 5.3 Navigating the Menu

### Installation Menu Navigation

The Installation Menu Chart is a multi-level structure divided into three columns from left to right		
<b>Level A</b> - lists the major menu categories.		
<b>Level B</b> - list the menu cells associated with Level A. You can enter data into Level B menu cells that are display parameters in a column at the right of the screen.		
<b>Level C</b> - lists the Level B data		
<b>Level A</b>	<b>Level B</b>	<b>Level C</b>
	Recall Site Setup	Pump 1 Pump 2
	Channel Enable	
	Create/Name Site	
	Site Security	
	Delete Site Setup	
Save/Rename Site		

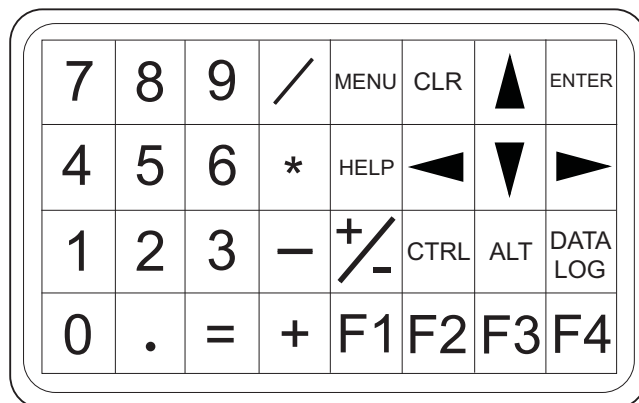

Figure 5-5 Keypad

#### Note

Use <Left Arrow> key to return to previous menus.

Table 5- 2 Keypad Function Chart

Keys	Description
MENU	Press to activate the Installation Menu.
ENTER	Store numeric data, select from option lists, etc.
Left / Right Arrows	Menu navigation keys move cursor.

Keys	Description
Up / Down Arrows	Same as <Left> and <Right> arrows. Scrolls option lists and graphic display screen.
CLR	Erases data or selects list options.
Numbers 0 - 9	Use to type numeric data.
Decimal Point	Use for decimal points in numeric data.
Math Operators	4-function math operations in numeric entry cells.
"F" Keys 1, 2, and 3	Used to start/stop/reset Totalizer.
F4	Caution: used during power up for system reset.
CTRL and ALT	Used as shift keys for alternative key functions.
DATALOG	Triggers immediate Datalogger report.
Plus and Minus [+ / -]	Changes the sign of numeric data.

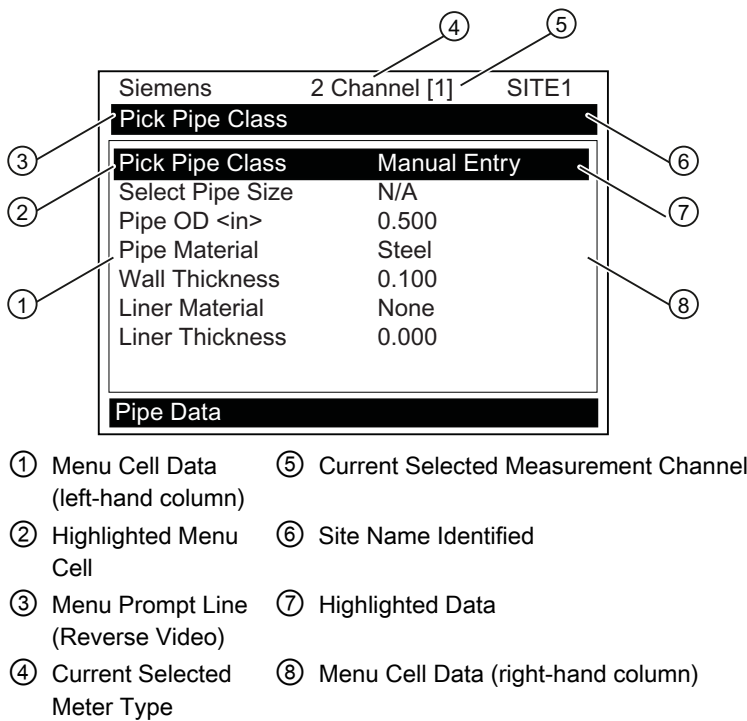

Figure 5-6 Typical Installation Menu Screen

## 5.4 Programming the Transmitter

### Select Language and Units

---

**Note**

Before creating a site select a language and then English or Metric units from the Meter Facilities menu.

---

**Note**

To set English or Metric units: In the Meter Type menu, scroll to Meter Facilities Menu. Press <Right Arrow> and select desired units. Press <ENTER> to select. Press <Left Arrow> and <Up Arrow> to return to Meter Type menu.

---

### Select a Meter Type

1. Press the <MENU> key and select the Meter Type.
2. Press the Right Arrow> and scroll to [2 Chan Energy]

---

**Note**

Select [2 Chan Energy] if measuring two different pipes and [2 Path Energy] if sensors are mounted on the same pipe.

---

3. Press <ENTER> to select.
4. Press <Right Arrow> to select meter function. Press <ENTER>.

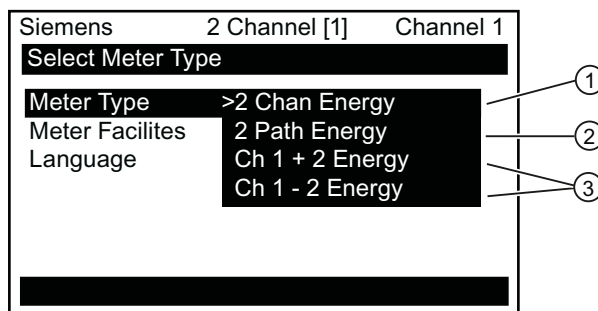

- ① Select for measuring two different pipes. (Not available for all models.)
- ② Select if two sensors are mounted on the same pipe.
- ③ Select for summing or subtracting flow from two different pipes.

### Create a Site

1. At the [Channel Setup] menu press <Right Arrow>.

---

**Note**

Before proceeding make sure that English or Metric units have been selected.

---

2. Press <Down Arrow> to select [Create/Name Site] menu and enter a Site name.
3. Press <Right Arrow> To create Site name.
4. Press <ENTER> to create Site name (e.g., ABC). (See figure below.)

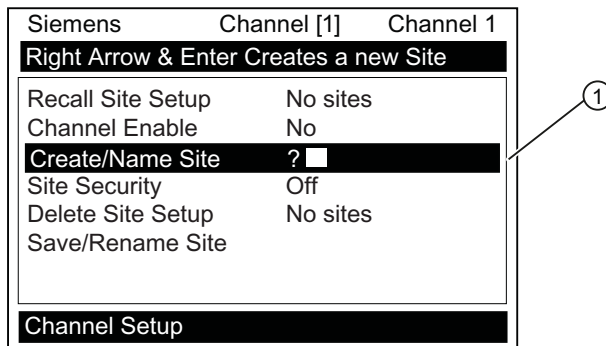

- ① Insert desired name (8 characters max.)
- 

**Note**

To select letters: Press <Right Arrow> to cursor and then press <Up/Down Arrow> to select letters and numbers. Press <ENTER> when done.

---

5. Press the <Left Arrow> and return to the [Channel Setup] menu.

## Selecting Pipe Data

Pipe Class is a pre-loaded set of default pipe sizes for various ASA and metric pipes. If the intended pipe is standard the user may select this function to pre-load necessary pipe data, otherwise enter data manually using [Pipe O.D.], [Pipe Material] and [Wall Thickness].

1. Press the <Right Arrow> to select [Select Pipe Class]. Press <Right Arrow> again and scroll to desired Pipe Class.
2. Press <ENTER> to select.

Siemens	2 Channel [1]	ABC
<b>Select Pipe Class</b>		
<b>Select Pipe Class</b>	<b>ASA Carb. Steel</b>	
Select Pipe Size	8CS40	
Pipe OD <in>	8.625	
Pipe Material	Steel	
Wall Thickness	0.322	
Liner Material	None	
Linear Thickness	0.000	
<b>Pipe Data</b>		

3. Pre-programmed Pipe Size and relevant pipe parameters will appear in menu cells. Press <Right Arrow> and scroll to desired pipe size. Press <ENTER>. Enter dimensions manually if pre-programmed dimensions do not match application.

### Note

The DN sizes listed in the [Select Pipe Size] menu option list are referenced to DIN Table 2448. After selecting pipe size, check pipe OD and wall thickness for correct dimensions.

4. Press the <Left Arrow> and return to the [Channel Setup] menu.

## Select Liquid Class

1. Press the <Down Arrow> and scroll to [Application Data].
2. Press the <Right Arrow> to select [Liquid Class].
3. Press the <Right Arrow> again and scroll to desired liquid.
4. Press <ENTER> to save selection.

Siemens	2 Channel [1]	ABC
<b>Select Liquid Class from Liquid Table</b>		
<b>Liquid Class</b>	<b>Water 20C/68F</b>	
Location	Return	
Service	Heating	
Temp. Range	-40F to 250F	
Pipe Config	Fully Developed	
Anomaly Diams	10	
<b>Application Data</b>		

- ① Select from list.

**Select Location and Service**

1. Scroll down to [Location] and press <Right Arrow>.
2. Press <Right Arrow> to select Location option list.

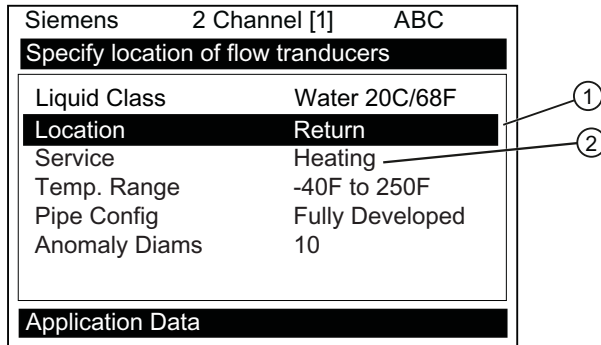

- ① Location option list.- where the sensors will be located, i.e. at the Supply (source) or Return of the fluid.
- ② Service option list

3. Press <Right Arrow > again and scroll to desired selection.
4. Press <ENTER> to save selection.
5. Cursor will move down and highlight [Service].
6. Press <Right Arrow> to highlight Service option list.
7. Press <Right Arrow> again and scroll to desired selection.
8. Press <ENTER> to save selection.

**Select Pipe Configuration**

1. Scroll down to [Pipe Config] and press the <Right Arrow>.
2. Select a configuration that approximates the conditions upstream of your sensor mounting location. (Refer to the definitions below.)
3. Press <ENTER> to save selection.

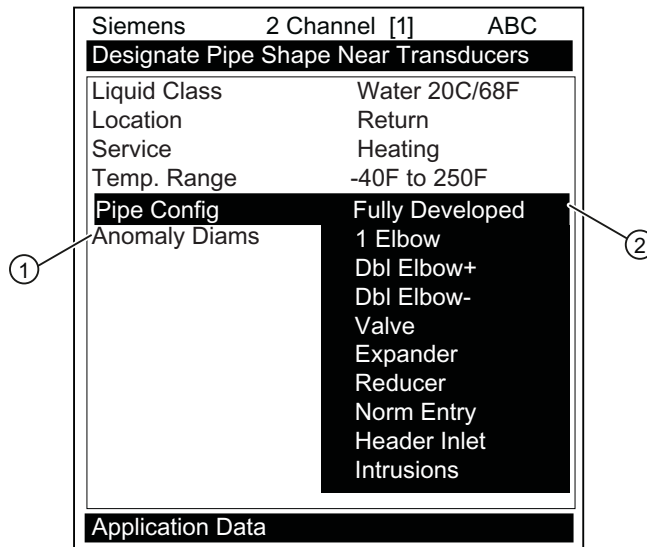

- ① Use this menu cell to enter the number of pipe diameters between the upstream configuration and the sensor installation.
- ② Use this menu cell to select the pipe configuration that most accurately represents the upstream pipe condition.

4. Press the <Left Arrow> and return to the main menu.

Table 5- 3 Pipe Configuration Option List Definitions

Options	Definitions
<b>Fully Developed</b>	Fully developed flow, as would be expected for very long straight pipe runs or installation downstream of a flow condition.
<b>1 Elbow</b>	Single 90 degree Elbow upstream of sensor installation.
<b>Dble Elbow+</b>	Double out-of-plane Elbows upstream of sensor installation.
<b>Dble Elbow-</b>	Double in-plane Elbows upstream of sensor installation.
<b>Valve</b>	Not available at this time.
<b>Expander</b>	Pipe expansion upstream of sensor installation.
<b>Reducer</b>	Pipe reduction upstream of sensor installation.
<b>Norm Entry</b>	Not available at this time.
<b>Header Inlet</b>	Header or pipe manifold upstream of sensor installation.
<b>Intrusions</b>	Not available at this time.

### Save/Rename Site procedure

Whenever new site configurations are added to an existing site that site must be saved again to retain the new site changes.

1. To save all programmed data to site, press <Left Arrow> and then scroll up to [Channel Setup].
2. Press <Right Arrow> and scroll to [Save/Rename Site].

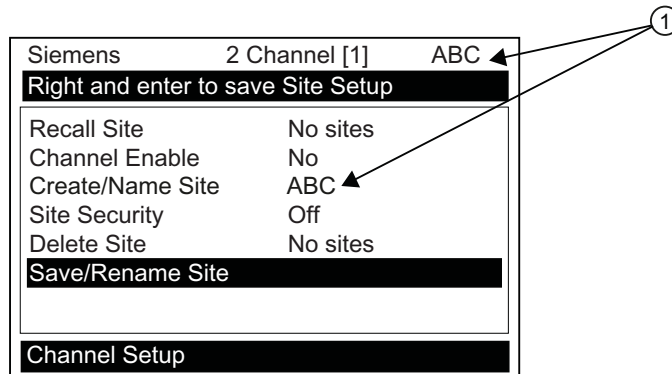

① The saved site name now appears in the menu screen.

3. Press <Right Arrow> and then <ENTER> to save all programmed data to site.
4. To return to the top menu level, continue to press the <Left Arrow> key.

## 5.5 Sensor Installation

### 5.5.1 Preliminary Installation Procedures

#### Reflect and Direct Sensor Mounting

Reflect and Direct mounting modes are supported for clamp-on sensors. The flow meter recommends a mounting mode after analyzing your pipe and liquid data entries.

---

#### Note

When installing sensors, do not key in the V/M (Version/Modification) label number as the Sensor Size.

---



### Clamp-on Sensor Mounting Modes

The transmitter recommends a mounting mode after analyzing your pipe and liquid data entries. However, you can install clamp-on sensors in the way that best suits your application and the sensor type you have purchased.

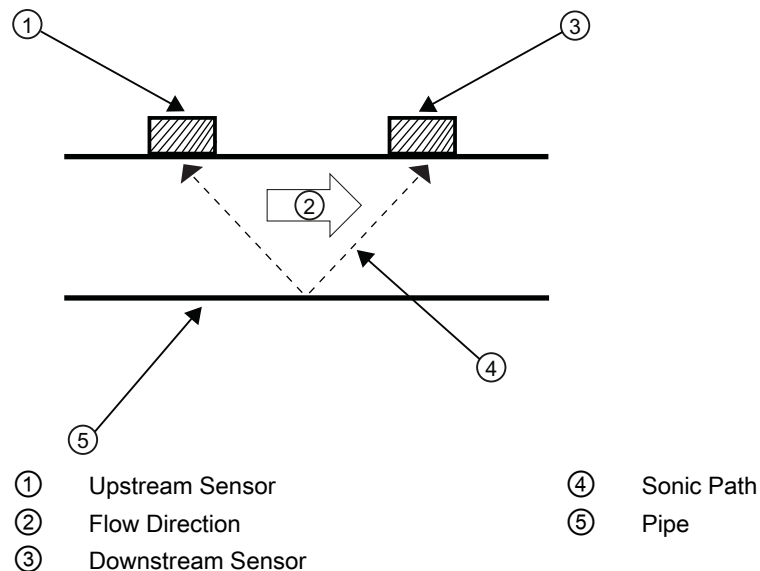

Figure 5-7 Reflect Mount (Pipe shown from above in 12 o'clock position)

Reflect mount is recommended whenever possible. This is the simplest way to mount the sensors. Also, Reflect mount resists abnormal flow profile conditions such as cross-flow within the flow stream. Reflect mount supports the AutoZero function, which zeroes the flow meter automatically without user-participation. In addition, Reflect mount may be the only possibility if conditions do not allow access to the opposite side of the pipe.

Direct mount provides a shorter sonic beam path. This usually improves performance with sonically attenuative liquids or pipe materials. Direct mount is recommended for plastic pipes. Compared to Direct mounting, Reflect mount requires almost double the amount of mounting length. Therefore, Direct mount may be the only option if the availability of mounting space is limited.

5.5 Sensor Installation

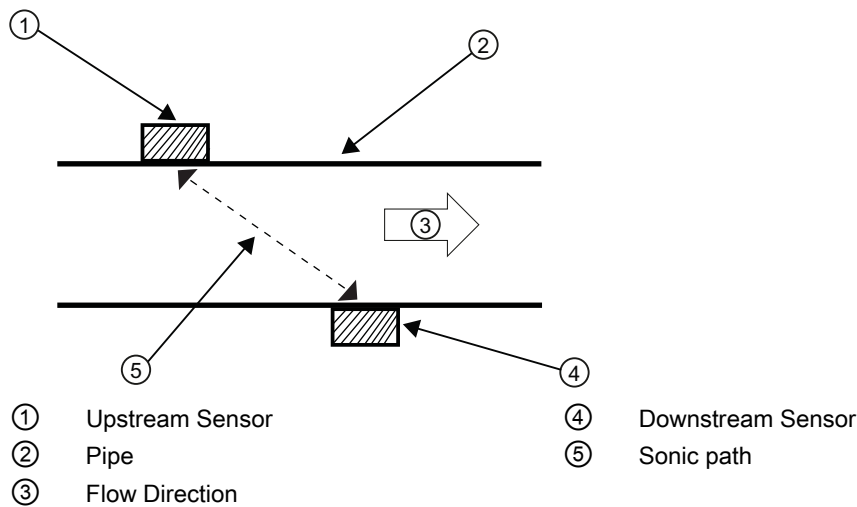

Figure 5-8 Direct Mount (Pipe shown from above in 12 o'clock position)

Mounting Supplies

The following items will be needed to mount the sensors (most are supplied):

- Flat blade screwdriver
- Mounting Frames or Mounting tracks
- Tape, chalk and a ruler or measuring tape
- Mounting Straps
- Spacer Bar
- Mounting Guide (for Direct Mount)
- Ultrasonic coupling compound and/or coupling pads
- Sensors (matched set)

Mounting Strap Kits

The available Mounting Strap kits are listed below. Each kit comes with up to two band sizes to cover its designated pipe diameter range and a spacing guide for Direct Mount.

Mounting Strap Kits	Pipe Diameter	SAE Band Sizes (Qty.)
7ME396000SM00	50.8mm (2-inch) to 177.8mm (7-inch)	#88 (2) #128 (2)
7ME396000SM10	50.8mm (2-inch) to 330.2mm (13-inch)	#88 (2) #152 (2)
7ME396000SM20	330.2mm (13-inch) to 609.6mm (24-inch)	#188 (2) #280 (2)
7ME396000SM30	609.6mm (24-inch) to 1219.2mm (48-inch)	#152 (4) #312 (4)

### Selecting a location for the sensors

1. Locate the sensors downstream from the center of the longest available straight run. A location ten pipe diameters or greater downstream from the nearest bend will provide adequate flow profile conditions.
2. Do not, if possible, install the sensors downstream from a throttling valve, a mixing tank, the discharge of a positive displacement pump or any other equipment that could possibly aerate the liquid. The best location will be as free as possible from flow disturbances, vibration, sources of heat, noise, or radiated energy.
3. Avoid mounting the sensors on a section of pipe with any external scale. Remove all scale, rust, loose paint, etc., from the location.
4. Do not mount the sensors on a surface aberration (pipe seam, etc.)
5. Do not mount sensors from different ultrasonic flow meters on the same pipe. Also, do not run the sensor cables in common bundles with cables from other instrumentation. You can run these cables through a common conduit ONLY if they originate at the same flow meter.
6. Never mount sensors under water, unless you order submersible units and you install them in accordance with factory instructions.
7. Avoid mounting sensors on the top or bottom of a horizontal pipe. The best placement on a horizontal pipe is either the ten o'clock and two o'clock position for Reflect Mode, or one sensor at nine o'clock and one sensor at three o'clock for Direct Mode. Mounting on a vertical pipe is recommended only if flow is in the upward direction. When mounting on a vertical pipe flowing in a downward direction make sure there is sufficient back pressure in the system to maintain a full pipe.

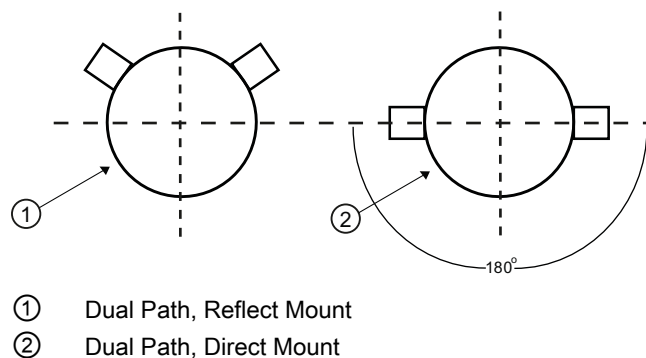

Figure 5-9 Sensor Alignment (Horizontal Plane)

### Preparing the Pipe

1. Pick a mounting location with the longest straight run. You must have easy access to at least one side of your pipe. The pipe at the mounting location must remain full, even at zero flow.
2. Decide on your mounting mode (Direct or Reflect). Always use Reflect Mode whenever possible. You may only need to use Direct Mode if your pipe is plastic.

- After receiving the spacing dimensions from the Installation Menu, prepare the pipe surface. De-grease the surface, if necessary, and remove any grit, corrosion, rust, loose paint, etc. Use abrasive material provided to provide a clean contact surface for the sensors.

**Note**

Please note that the instructions show vertical mounting for clarity purposes only. Do not install sensors on the top of a pipe.

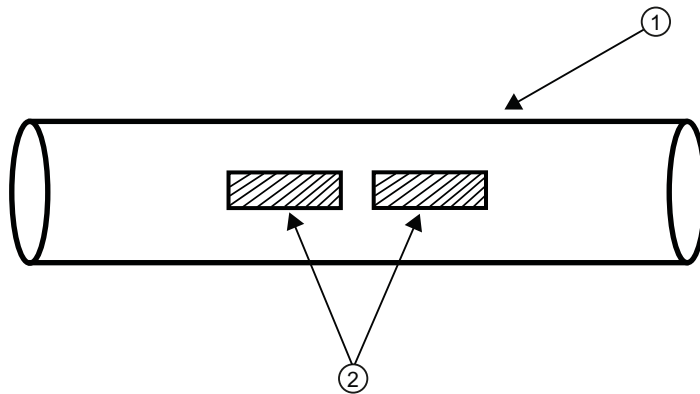

- ① Pipe
- ② Cleaned Areas

Figure 5-10 Pipe Surface Preparation

- Clean an area 13 mm (1/2-inch) on either side of the sensors.
- Clean an additional 13 mm (1/2-inch) along the length of the sensors.

### 5.5.2 Sensor Identification and Selection

#### Sensor identification

The sensor part number located on the front face provides a detailed identification. For example, the Part Number: 1011HNS-D1T1-S2 means:

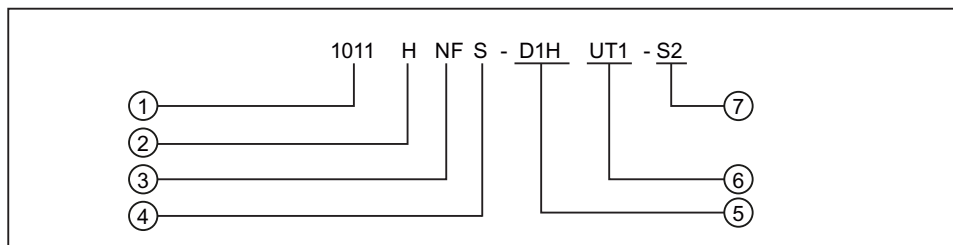

- ① Model
- ② Hi Precision
- ③ NEMA w/F-Conn
- ④ Pipe Material
- ⑤ Size
- ⑥ Temperature
- ⑦ Agency Approved

**Note**

Check to make sure that the sensors are a matched set with the same serial numbers and marked with an "A" and "B" (e.g., 19256A and 19256B).

**Note**

Sensor Model names for Version 3 op systems are as follows: 1011H Hi Precision, 1011 Universal and 991 Universal

**Typical Sensor Labels**

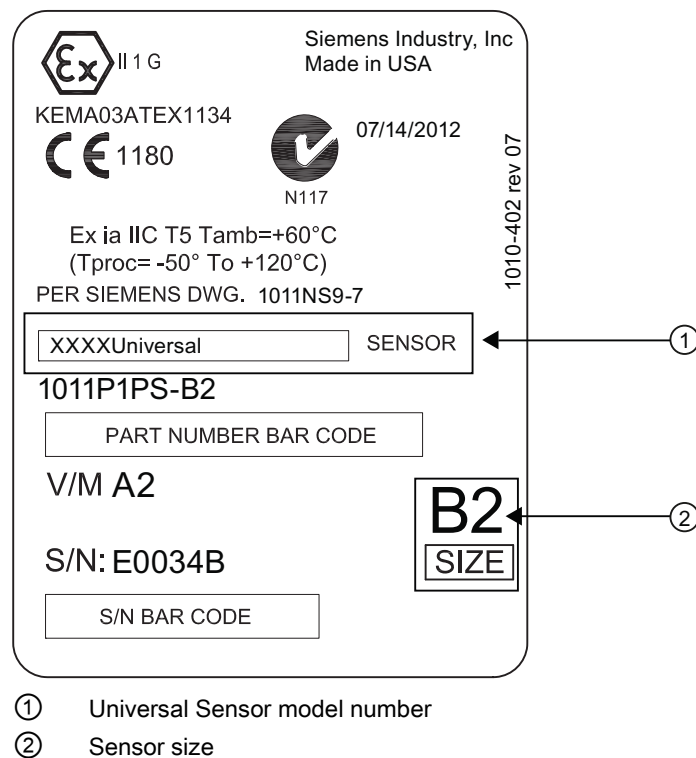
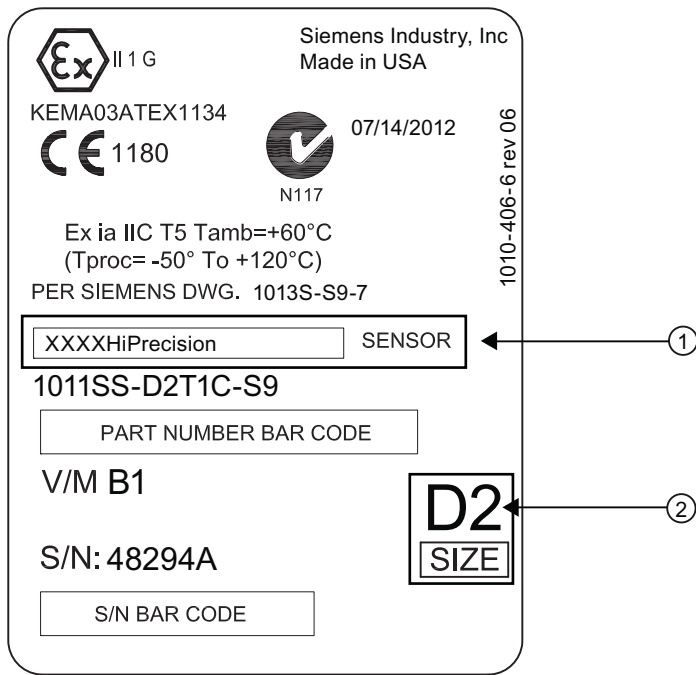

Figure 5-11 Universal Sensor Label



- ① Hi Precision sensor model number
- ② Sensor size

Figure 5-12 Hi Precision Sensor Label

### Sensor Selection

The following is a typical sensor selection procedure.

---

#### Note

The transmitter must be powered up before you can select a sensor model. Refer to Transmitter Wiring (Page 35).

---

1. Press <Left Arrow> to return to main menu. At [Meter Type], press the <Right Arrow> and then <ENTER>.
2. The [Channel Setup] menu will appear.
3. Press the <Down Arrow> to select [install Sensor].
4. Press the <Right Arrow> to [Sensor Model]. Press <Right Arrow> and scroll to select the sensor model number on the sensor label.

5. The drop down menu lists the following sensor selections:
  - 1011 Universal
  - 1011HP-T1 - Usable -40 to 120°C, recommended for Ø Temperature <40°C; Standard.
  - 1011HP-T2 - Usable -40 to 120°C, recommended for Ø Temperature >40°C - <80°C; Named as high temperature.
  - 1011HP-T3 - Usable -40 to 120°C, recommended for Ø Temperature >80°C <120°C; special request.
  - 991 Universal

**Note**

The meter will automatically recommend a sensor depending on the application data that has been entered.

6. For this example, select the sensor model that appears on the sensor label then press <ENTER>.

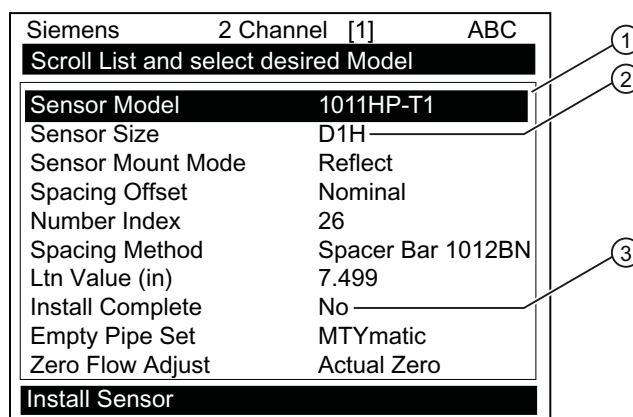

①	Select based on type
②	Select based on size
③	After sensor is mounted select "Install."

7. To select Sensor Size, press <Right Arrow>. Scroll to select the sensor size that matches the size indicated on the sensor label. Press <ENTER>.
8. At [Sensor Mount Mode], press the <Right Arrow>. Scroll to select [Reflect] or [Direct] mount and then press <ENTER>.
9. **IMPORTANT: Record Spacing Method and Number Index. This data will be used to mount the sensors.**
10. Sensors can now be mounted. Refer to Sensor Installation mounting procedures and select the mounting mode desired.
11. **After sensors are mounted scroll to [Install Complete] and select [Install].**

### 5.5.3 Reflect Mount

#### Reflect Mount - Sensor Installation using Mounting Frames and Spacer Bar

1. After receiving the spacing index from the Installation Menu, prepare the pipe surface area where the sensors will be mounted.
2. Degrease the surface and remove any grit, corrosion, rust, loose paint, etc.

Before beginning refer to the Reflect Mount Installation diagram example below.

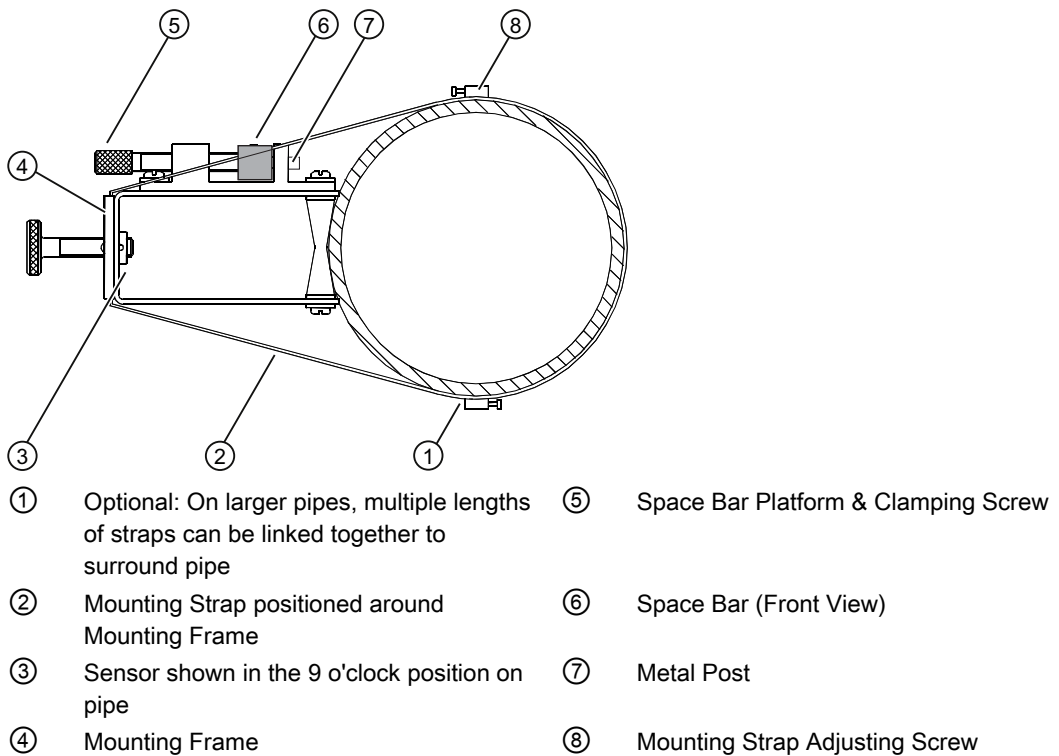

Figure 5-13 Reflect Mount with Mounting Frames and Spacer Bar

---

#### Note

Minimum Ltn 18 mm (0.75 in).

---

#### Ltn Menu Cell

This view only menu cell shows the distance in inches or millimeters between the front faces of the sensors along the axis of the pipe. If you are mounting the sensors without a track or spacer bar, you have to space them according to this value. Note that Ltn may be a negative number for direct mount on very small pipes where the sensor spacing overlaps.



## Preparing the Pipe

1. On a flat surface, attach the Spacer Bar to a Mounting Frame so that the Reference Hole on the Spacer Bar fits over the metal post on the platform of the frame. Tighten the clamping screw.
2. Slide the second Mounting Frame onto the other end of the Spacer Bar and align the Number Index Hole with the metal post on the platform. Then tighten the clamping screw. *Ensure that the angled sides of both frames face away from each other.*
3. Wrap a Mounting Strap around the pipe. Make sure to position it so there is easy access to the Mounting Strap Adjusting Screw.
4. At the mounting location, place the Mounting Frame/Spacer Bar Assembly on the pipe so that it rests on the top of the pipe.
5. Engage the end of the Mounting Strap with the Mounting Strap Adjusting Screw.
6. Slide strap under the spring clip of one of the Mounting Frames.
7. Tighten the Mounting Strap Screw enough to take up all of the slack, but not enough to prevent rotation of the assembly. *Repeat procedure for the other Mounting Frame.*
8. Rotate the assembly on the pipe to the final conditioned location, ensuring that it is straight along the pipe axis. (Refer to the sensor orientation diagram)
9. Tighten the mounting straps to seat the assembly firmly on the pipe. Do not over tighten.

Installing the Sensor

1. Take either sensor and apply a continuous lengthwise 3mm (1/8-inch) bead of coupling compound across the center of the sensor emitting surface.

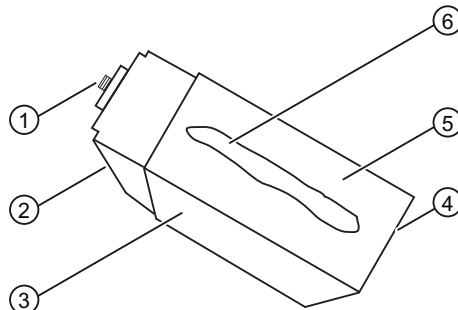

- |               |                     |
|---------------|---------------------|
| ① F-Connector | ④ Front Face        |
| ② Angled Edge | ⑤ Emitting Surface  |
| ③ Sensor      | ⑥ Coupling Compound |

Figure 5-14 Sensor

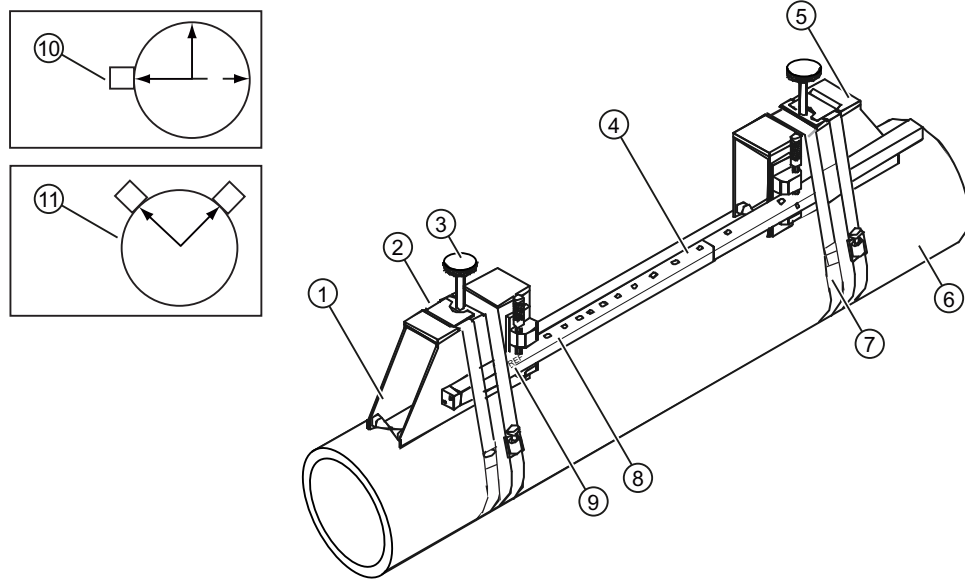

- |  |  |
|--|--|
| ① Front View                               | ⑥ Pipe   |
| ② Spring Clip (Not present on some models) | ⑦ Mounting Strap Note: Optional 2nd Mounting Strap shown. Larger pipes over 76cm (30 inches) may need an additional support. |
| ③ Sensor Clamping Screw                    | ⑧ Spacer Bar Platform and Clamping Screw   |
| ④ Spacer Bar                               | ⑨ Spacer Bar Reference Hole  |
| ⑤ 7ME39600M Mounting Frame                 | ⑩ Orientation for Single Beam Sensor at 9 o'clock position   |
|  | ⑪ Orientation for Dual Beam Sensor at 10 & 2 o'clock positions   |

Figure 5-15 Sensor Installation

2. Slide sensor into a mounting frame back end first aligning the angled edge of the sensor with the angled edge of the mounting frame. Keep sensor from making contact with the pipe until it butts up against the mounting frame stop. Push sensor down to mate with pipe.
3. Tighten the sensor clamping screws to hold the sensor firmly in place. *Repeat procedure for the other sensor.*
4. If installing a temperature sensor proceed to Mounting Temperature Sensor (Page 31). If not, proceed to Sensor Wiring (Page 80).

## 5.5.4 Direct Mount

### Sensor Installation using Mounting Frames, Spacer Bar and Spacing Guides

The combination of mounting frames, spacer bar and spacing guides is the recommended way to mount Direct Mode sensors. The mounting frame establishes the axial alignment of the sensors and allows you to remove and replace either sensor while preserving their exact mounting location.

For Direct Mode mounting, a spacer bar is used to establish the distance between sensors and a spacing guide to locate the sensors at the nine o'clock and three o'clock positions. Should the distance between sensors be beyond the span of a spacer bar, a measuring tape can be used. The Mylar spacing guide comes in various lengths and widths to accommodate most pipe sizes.

Spacing Guide Sizes	
Metric	English
5.08cm x 66.04cm	2" x 26"
5.08cm x 114.3cm	2" x 45"
10.16cm x 393.7cm	4" x 155"
15.2cm x 497.8cm	6" x 196"

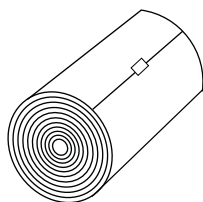

Figure 5-16 Mylar Spacing Guide

1. After receiving the spacing index from the Installation Menu, prepare the pipe surface area where the sensors will be mounted.
2. Degrease the surface and remove any grit, corrosion, rust, loose paint, etc.
3. Make a note of the Number Index displayed in the [Install] menu. Check to ensure that you have a matched set of sensors. They both should have the same S/N number but marked with either an "A" or "B" (e.g., 100A and 100B).

4. Temporarily position one of the frames on the pipe where you will be mounting it. Ensure that this is a smooth area without any raised areas (seams, etc.) With a pencil or chalk, mark a generous area of 13 mm (1/2") all around the frame. Remove the assembly.
5. Prepare the area you marked by de-greasing surface, if needed, and removing any grit, corrosion, rust, loose paint or surface irregularities with the abrasive material provided
6. Put a mounting strap around the pipe and engage an end into adjusting screw (screw should be pointing up). Position frame in the middle of area you have cleaned and centered on the pipe with its angled end facing away from where the other frame will sit.

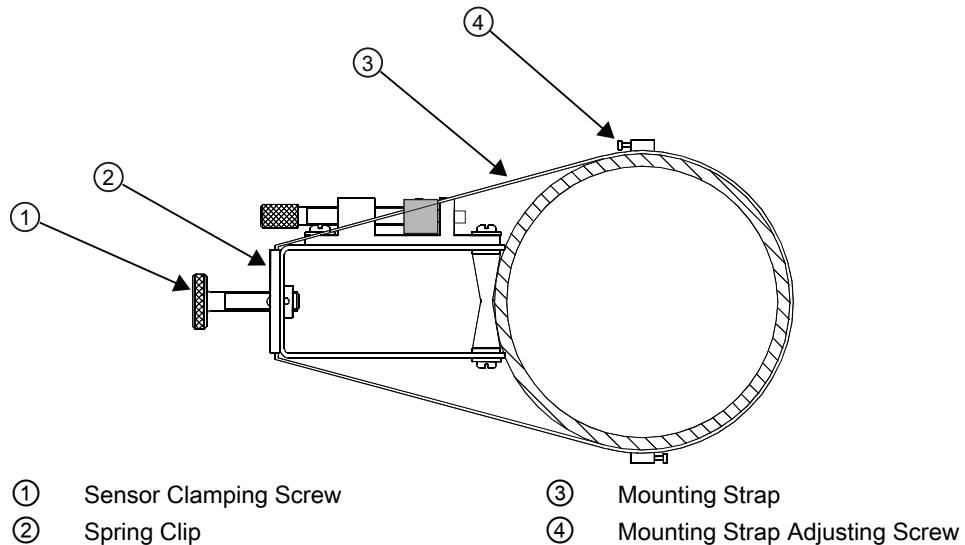
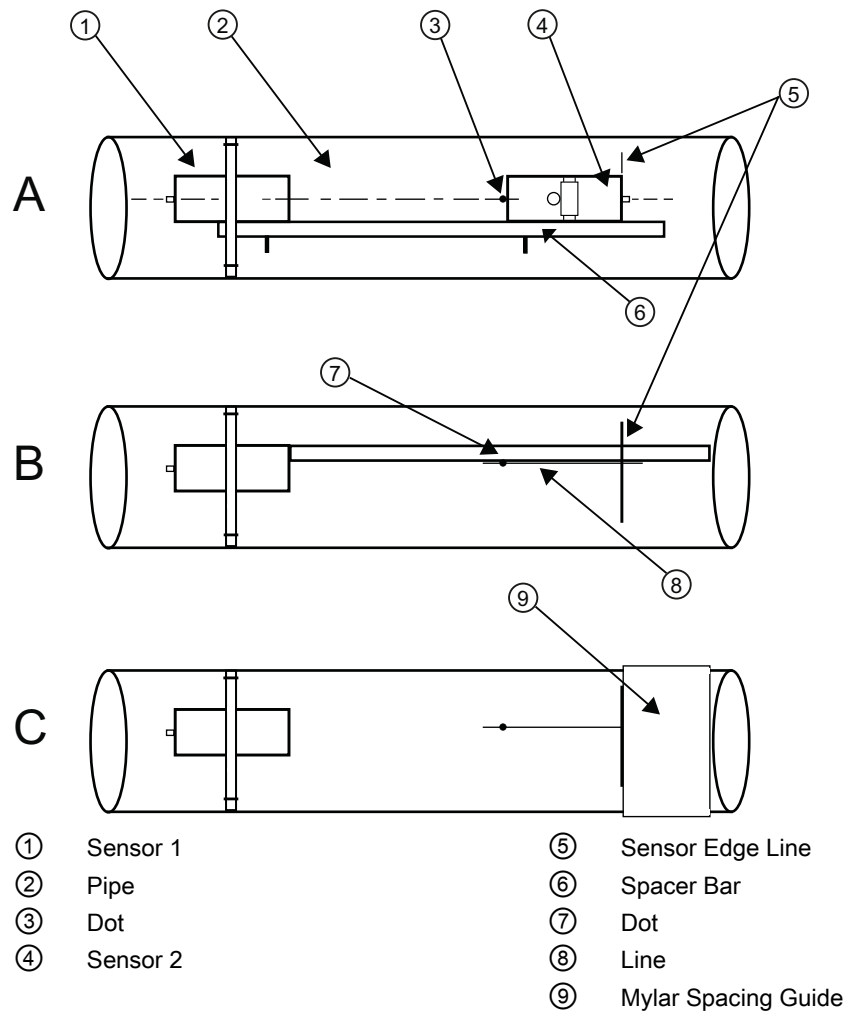

Figure 5-17 Wrap Strap Under Pipe and Attach to Adjusting Screw

7. Slide the mounting strap over it (and under the clip if there is one) and tighten with a screwdriver. While tightening, check to ensure that the center of the tapered roller is centered on the pipe.
8. Attach the second frame to the spacer bar with an index spacer screw into the index hole specified in Step 1. The angle on the frame should be facing away from the direction that the length of the bar is going.
9. Now attach the free end of the spacer bar by inserting an index spacer screw through the REF hole on the spacer bar and then into the hole on the mounted frame. Tighten. Sight to ensure that this frame is lined up in center of pipe and while holding alignment, place a dot (with pencil or chalk) in the center of the tapered roller at the bottom of the frame (see A below). While holding, also mark along the front edge of the frame with pencil or fine chalk line (see B below).



10. Disassemble the spacer bar and the unmounted frame. Use the bar as a straight edge and, with one edge against the mounted frames tapered roller center and the other crossing the dot you drew, draw a line crossing the dot (see "B" above). Set the bar aside.

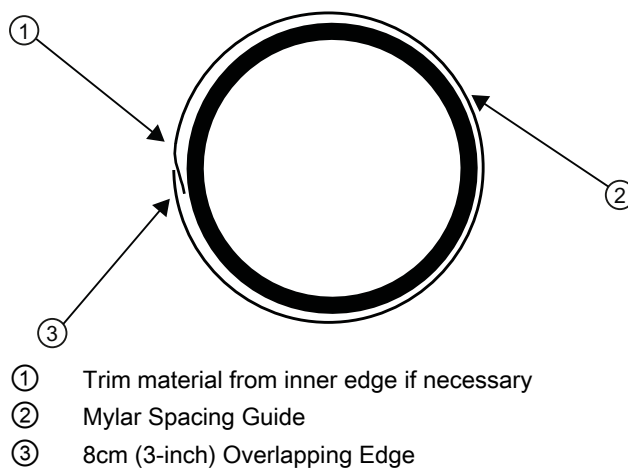

Figure 5-18 Wrapping the Mylar Spacing Guide around the pipe (End View)



16. Prepare the area you marked by de-greasing the surface, if needed, and removing any grit, corrosion, rust, loose paint or surface irregularities with the abrasive pipe conditioning material provided. Clean the pipe of any debris and abrasive particles.
17. Replace the Mylar guide back in the same position it was in and retape it to the pipe
18. Put a mounting strap around the pipe and engage an end into adjusting screw (screw should be pointing up).
19. Position frame in the middle of area you have cleaned and centered on the pipe with its angled end facing away from where the other frame will sit and aligned with the edge and center marks on the guide. Slide the mounting strap over it (and under the clip if there is one) and tighten with a screwdriver. While tightening, check to ensure that the center of the tapered roller is centered on the pipe.
20. Take either sensor and apply a continuous lengthwise 3 mm (1/8-inch) bead of coupling compound across the center of the sensor emitting surface.
21. Tighten the sensor clamping screws to hold the sensor firmly in place. *Repeat procedure for the other sensor.*
22. Slide sensor into a mounting frame back end first aligning the angled edge of the sensor with the angled edge of the mounting frame. Keep sensor from making contact with the pipe until it butts up against the mounting frame stop. Push sensor down to mate with pipe.
23. Open the transmitter top cover. Using a flat blade screwdriver, remove the Cable Strain Relief bracket.
24. Observing the upstream and downstream orientation, attach the UP (upstream) and DN (downstream) cables to the sensors and make snug. Attach the other ends to the UP and DN terminals of the transmitter.
25. Replace the Cable Strain Relief bracket. Close top cover.
26. Proceed to Commissioning (Page 83).

## 5.5.5 1012T Mounting Tracks

### Using 1012T Sensor Mounting Tracks

The 1012TN and 1012TNH Mounting Tracks provide a rigid mounting platform for Series 1011 Universal or high precision size A or B sensors. The mounting tracks service pipe sizes up to a maximum of 140mm (5.00") outer diameter. The 1012T mounting tracks support both Direct and Reflect mounting modes. The transmitter recommends the appropriate sensors, mounting track and mounting mode, based on the pipe data entries.

### Installing a 1012T Mounting Track in Reflect Mode

The Sensor Installation procedures show how the automatic selection of sensors, mounting mode and spacing method are established. Examine the figure below, which illustrates a typical [Install Sensor] menu screen. Note the automatic assignment of mounting track part number, plus the designation of the number index.

Siemens	2 Channel [1]	SITE1
<b>Install Complete?</b>		
Sensor Model	1011HP-T1	①
Sensor Size	B3	①
Sensor Mount Mode	Reflect	①
Spacing Offset	Minimum	
Number Index	6	②
Spacing Method	Track 1012TN	②
Ltn Value (in)	0.581	
<b>Install Complete</b>		
Empty Pipe Set	Channel Not Setup	
Zero Flow Adjust	Channel Not Setup	
<b>Install Sensor</b>		

- ① Sensor type, size and mounting mode selection.
- ② Automatic selection of mounting track part number and number index.



1. Perform all required menu steps up until the point where you respond to the [Install Complete] prompt.
2. Make note of the Number Index. Check to ensure that you have a matched set of sensors. They both should have the same serial number but marked with either an "A" or "B" (e.g. 100A and 100B).

**Note**

Index pins are used as stops against each sensor inserted at the reference hole for one sensor and the Number Index hole for the other sensor (see ⑪ in figure below).

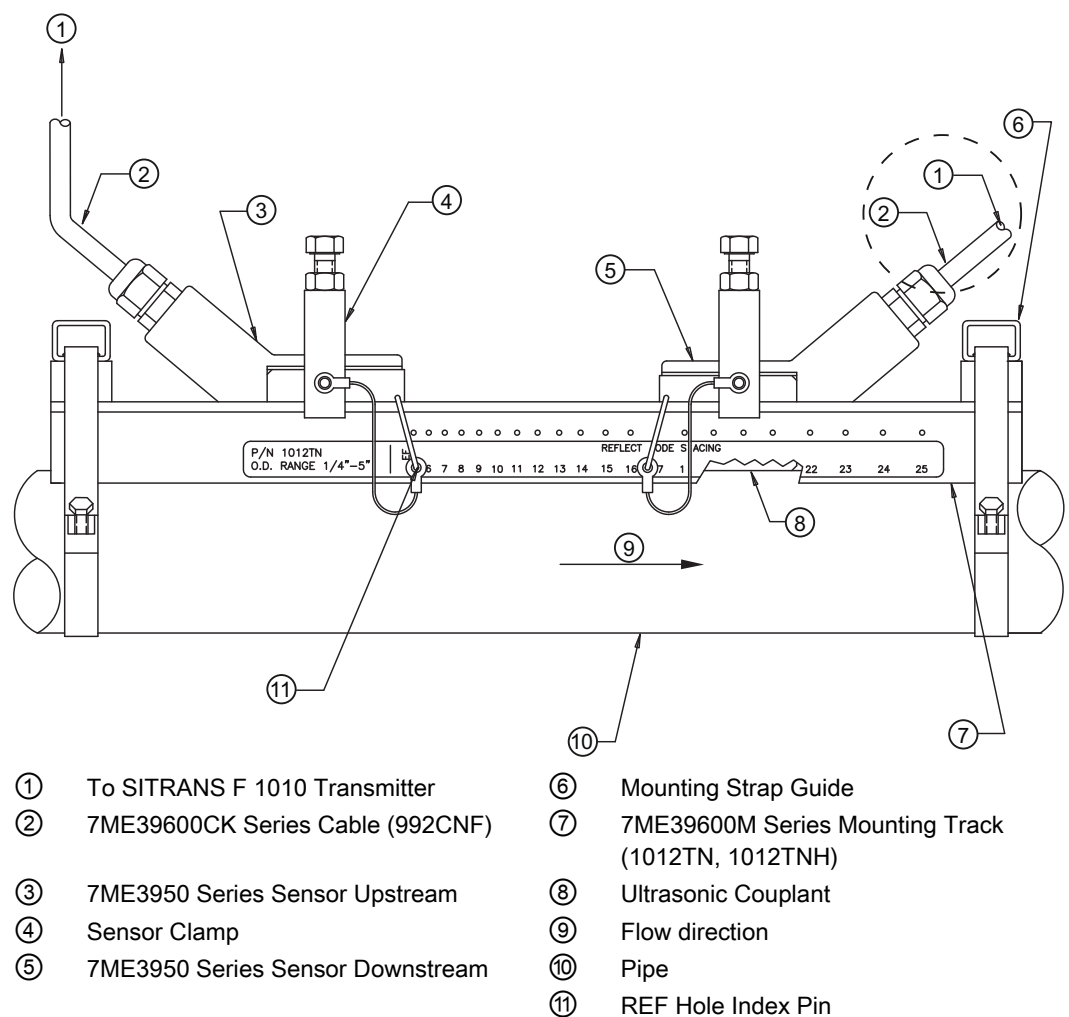

Figure 5-21 Reflect Mount with Model 1012TN Mounting Track (Side View)

3. Place the track rail assembly on the top surface of the pipe at the location where you have determined it would be mounted. Ensure that it is a smooth area without any raised spots or seams.
4. Holding the mounting track assembly in place, loop one of the strap clamps under the pipe, pull it around and maintain tension while slipping a link over the tension screw hook. Tighten the tension screw enough to hold the assembly on the pipe, but still allow rotation. Repeat for the other mounting strap.

5. Rotate the track rail assembly to the intended mounting position on the pipe, then tighten both tension screws just enough to prevent rotation. Do not over tighten.
6. With a pencil or chalk mark a generous area around the perimeter of the track assembly. Loosen and move the assembly away from marked area.
7. Prepare the area you marked by degreasing the surface, if needed, and removing any grit, corrosion, rust, loose paint or surface irregularities with the abrasive pipe conditioning material provided. Clean the pipe of all debris and abrasive particles.
8. Rotate the track into the position that was just cleaned. Insert the index pin into the REF hole.
9. Insert the index pin into the reference hole.
10. Select a sensor and apply a thin band of couplant compound to the sensor's emitting surface.
11. Place the sensor between the track rails, slightly behind the pin and under the clamping screw assembly. Slide it forward until it butts up firmly against the reference pin.
12. Once the sensor is in place secure it with the sensor clamping screw. Do not over tighten.
13. Repeat the procedure for the Number Index sensor making sure to insert an index pin into the correct Number Index hole. Refer to the Model 1012TN Mounting Track (side view) figure above.
14. Observing the upstream and downstream orientation, attach the UP (upstream) and DN (downstream) cables to the sensors and make snug. Attach the other ends to the UP and DN terminals of the flow meter.

### Installing a 1012T Mounting Track in Direct Mode

The Sensor Installation procedures show how the automatic selection of sensors, mounting mode and spacing method are established. Examine the figure below, which illustrates a typical [Install Sensor] menu screen. Note the automatic assignment of model numbers for the sensor and mounting track, plus the designation of the number index.

Siemens 2 Channel [1] SITE 1	
<b>Install Complete?</b>	
Sensor Model	1011HP-T1
Sensor Size	B3
Sensor Mount Mode	Direct
Spacing Offset	Minimum
Number Index	4
Spacing Method	Track 1012TN
Ltn Value (in)	0.217
<b>Install Complete</b>	<b>No</b>
Empty Pipe Set	Channel Not Setup
Zero Flow Adjust	Channel Not Setup
<b>Install Sensor</b>	

① Automatic selection of mounting track part number , mount mode and number index

The combination of two Model 1012TN Mounting Tracks and a spacer guide is the recommended way to mount sensors in the Direct Mode. This method ensures that sensors will align exactly 180° from each other and remain spaced the proper distance apart.

The Direct Mount configuration uses a set of two track rail assemblies; one for each sensor, installed 180° apart on the pipe. The set includes:

- Reflect Mode Track Assembly - This track rail includes the Tension Screw and REF hole to position one sensor.
- Direct Mode Track Assembly - This track rail has number index holes for inserting an index pin to position the other sensor.

**Note**

A pin will be inserted into the hole designated by the Number Index on the Direct Mode track rail to position one of the sensors (see ⑩ in figure below).

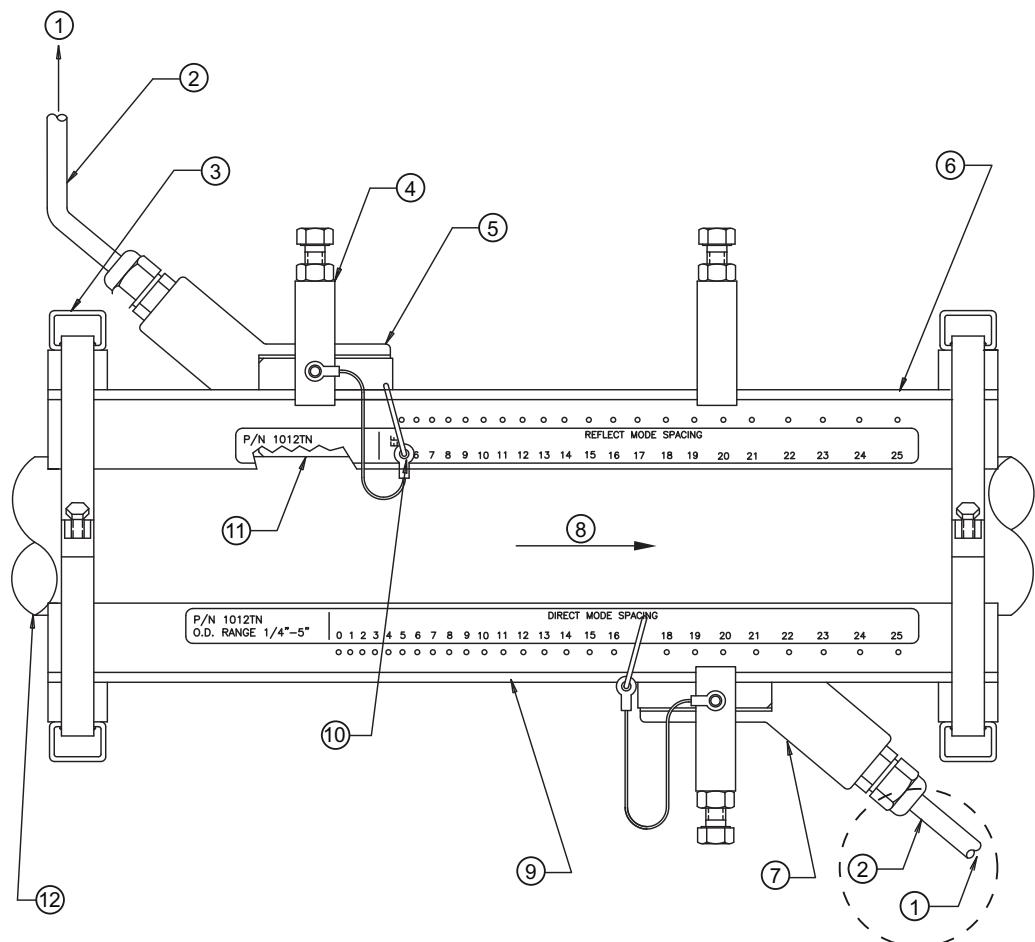

- |   |   |
|---|---|
| ① To SITRANS F Transmitter                          | ⑦ 7ME3950 Series Sensor Downstream                  |
| ② 7ME39600CK Series Cable (992CNF)                  | ⑧ Flow direction                                    |
| ③ Mounting Strap Guide                              | ⑨ 7ME39600M Series Mounting Track (1012TN, 1012TNH) |
| ④ Sensor Clamp                                      | ⑩ REF Hole Index Pin                                |
| ⑤ 7ME3950 Series Sensor Upstream                    | ⑪ Ultrasonic Couplant                               |
| ⑥ 7ME39600M Series Mounting Track (1012TN, 1012TNH) | ⑫ Pipe  |

Figure 5-22 Direct Mount 180° opposed with Mounting Tracks

1. Perform all required menu programming steps up until the point where you respond to the [Install Complete?] prompt.
2. Make a note of the reported Number Index displayed in the [Install Sensor] menu. Check to ensure that you have a matched set of sensors. They both should have the same serial number but marked with either an "A" or "B" (e.g. 100A and 100B).

---

**Note**

Some sensors require a right-angle adapter. This adapter should be installed before placing the sensors in the tracks.

---

3. Prepare pipe for the track mounts by degreasing the surface, if needed, and removing any grit, corrosion, rust, loose paint or surface irregularities with the abrasive pipe conditioning material provided.
4. If this is a horizontal pipe, place the track rail assembly against the pipe. While holding track, place second track on pipe directly underneath (180°) and hold together in place.
5. Wrap the mounting strap around the pipe and through the strap guide.

---

**Note**

For a vertical pipe installation, use a tie, tape or bungee cord to hold the two tracks in place while mounting.

---

6. Finger-tighten the chain Tension Screw to secure the strap and tracks to the pipe.

## Positioning Track Assemblies

1. Wrap a length of the Mylar spacing guide around the pipe and against the end of the track assemblies. Ensure that the spacer guide edges on both sides align. Arrange so that one end overlaps the other by at least 8 cm (3 inches). Trim to fit if necessary, but in order to keep the end square, be sure not to trim at the overlapping end.

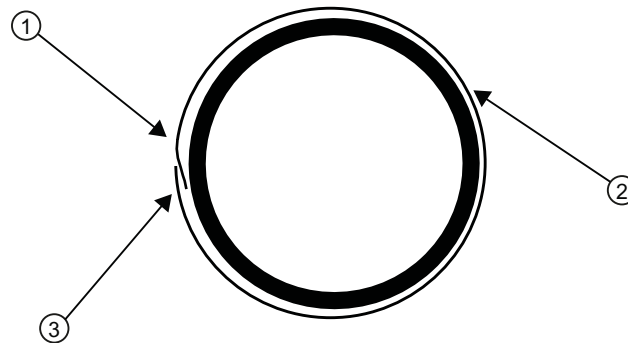

- ① Trim material from inner edge if necessary
- ② Mylar Spacing Guide
- ③ 8 cm (3-inches) Overlapping Edge

Figure 5-23 Wrapping the Mylar Spacing Guide around the pipe (End View)

2. Remove the spacer guide. Measure or fold spacer guide to find its halfway distance. Mark a center line and then tape spacer guide to pipe.

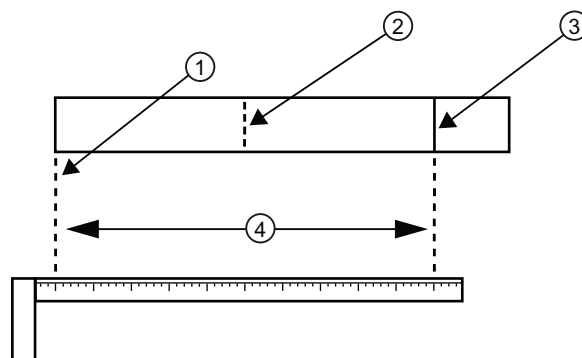

- ① Overlap Edge
- ② Mark (or fold) exactly at half-way point
- ③ Mark on Spacing Guide
- ④ Circumference

Figure 5-24 Finding the Halfway Distance

3. Use the edge of the Spacer Guide as a stop for both tracks to keep them parallel. Adjust tracks as necessary.

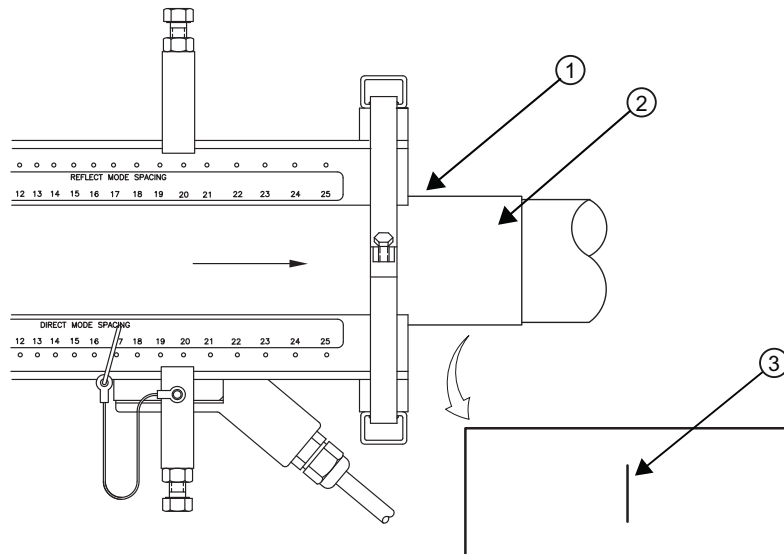

- ① Align tracks with Spacer Guide edge
- ② Mylar Spacer Guide
- ③ Halfway distance of Spacer Guide

Figure 5-25 Track Rail Alignment

4. Loosen the mounting straps enough to allow you to rotate the track assembly until the center of one track aligns with the center line on the Spacer Guide and the center of the other track aligns at the point where the Spacer Guide ends meet. The tracks should now be 180° apart. Tighten both chains but not too tight.

## Sensor Installation

1. Insert an index pin into the REF hole of the track marked "Reflect Mode Spacing."
2. Take one of the sensors and insert it between the track rails and to the left of the index pin with the cable connector pointing away from the pin. Move the sensor until the pin stops it. Hold sensor in place. Move sensor clamping screw over the sensor and tighten.

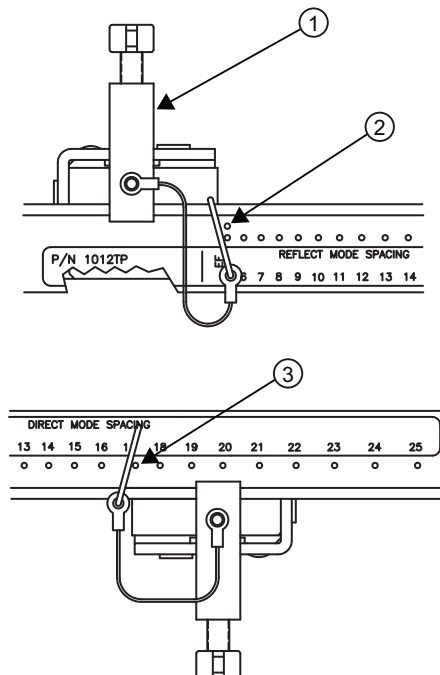

- ① Sensor Clamping Screw
- ② REF hole
- ③ Number Index hole

Figure 5-26 REF and Number Index Pin Locations

3. Insert the other index pin into the correct Number Index hole on the other track marked "Direct Mode Spacing."
4. Insert the second sensor into the track rail with its cable connector pointing away from the pin. Move the sensor until it's stopped by the pin. Move sensor clamping screw over the sensor and tighten.
5. Using a pencil or chalk, mark a generous area around where the sensors contact the pipe.
6. Release the tension on the sensors and remove them.
7. Loosen the mounting straps and rotate the track assembly on the pipe so you can gain access to the areas marked.
8. Prepare the areas you marked by degreasing the surface, if needed, and removing any grit, corrosion, rust, loose paint or surface irregularities with the abrasive pipe conditioning material provided.
9. Rotate the track assemblies into their original position on the pipe. Use the edge of the Mylar guide as a stop for both tracks and keep them parallel. Align each track with the "center line" you previously marked on the Spacing Guide. Tighten tracks securely.

10. This time, before installing each sensor, apply a 3mm (1/8-inch) continuous bead of couplant compound along the center (the long way) of the contact surface of the sensor. Also, keep the sensors lifted slightly from the pipe when installing until the sensor is against the pin; then push down against the pipe.

---

**Note**

Remember to install the sensors with the cable connectors facing away from each other.

---

11. Once the sensors are in place, secure with its clamping screws. Do not over tighten.
12. Observing the upstream and downstream orientation, attach the UP (upstream) and DN (downstream) cables to the sensors and make snug. Attach the other ends to the UP and DN terminals of the flow meter.
13. Proceed to Commissioning (Page 83).

## 5.5.6 Zero Flow Adjust Menu

### Zero Flow Compensation Methods

Unlike turbine flow meters ultrasonic transit-time flow meters provide active flow measurement right down to zero flow, however, the measurement of the transit-time delta is dependent on the similarity or "match" of the electronics, cables and ultrasonic sensors. Consequently some flow offset (or zero offset) may be present in any installation. To eliminate this residual zero offset Siemens has developed several different methods to insure proper zero flow compensation. The following paragraphs describe each method and when they should be used.

#### AutoZero

When the 1011HP sensors are mounted in the Reflect Mode configuration the AutoZero routine is automatically invoked at the end of the Initial Makeup. Flow does not have to be stopped to perform AutoZero since only the pipe wall signal is used in determining the zero offset and not the liquid component. The AutoZero routine performs a one-time analysis of the pipe wall component of the ultrasound signal to quantify any residual mismatch in the hardware. Once the AutoZero routine is complete, the system memorizes this measured zero offset and subtracts this value from the flow reading.

#### Actual Zero

The Actual Zero function simply averages the indicated "zero flow" readings (over a user defined time period) then stores this average value in memory. Under normal operation the indicated flow reading is zero compensated by simply subtracting this memorized value from the uncompensated flow reading. Actual Zero is the most positive method for zeroing the system; however, flow must be stopped with the line blocked (if possible) before invoking this function. If stopping flow is not possible then an alternate zeroing method should be selected.



## ReversaMatic

This routine involves swapping the Up and Down sensors on the pipe (while keeping the cables attached) such that the difference in the transit-time change represents the zero offset. The fixed zero offset value is stored in memory in the same manner as described in Actual Zero. This routine would generally be used whenever flow cannot be stopped and the sensors cannot be mounted in the Reflect Mode configuration. Flow must be stable during the entire process.

## ZeroMatic

When ZeroMatic is invoked the flow meter first performs the same analysis as described above in the AutoZero routine. However, after this analysis is complete the flow meter continues to interrogate the pipe wall signal and update the zero offset value under normal operation, such that the flow meter dynamically compensates for changing conditions which would normally result in zero drift. ZeroMatic will only operate with the sensors mounted in the Reflect Mode configuration and is recommended for applications which experience large temperature extremes.

---

### Note

Invoking ZeroMatic will clear any existing "fixed" or memorized zero offset. If any zero offset remains after flow is stopped, an Actual Zero can be performed without interrupting ZeroMatic operation. To disable ZeroMatic, invoke it again, but then press <Left Arrow> to abort the installation.

---

### Note

The ZeroClr command only resets the memorized zero offset registers not those set when the AutoZero routine is invoked.

---

## Using Actual Zero

---

### Note

Flow must be stopped with the line blocked (if possible) before invoking this function.

---

**To invoke Actual Zero:**

1. Access the [Zero Flow Adjust] option list by pressing <Right Arrow>.
2. Press <ENTER>. A pop-up window prompts you to set the current flow rate (in selected rate units) to equal zero (0.000).

---

**Note**

If a flow offset is desired (i.e., to test analog outputs) then press <Right Arrow> to enable numeric entry.

---

3. Press <ENTER> to start the Actual Zero process.

When you send the command, the flow meter analyzes the current flow rate for up to sixty seconds, integrating (averaging) the data for the best zero correlation. During this time, the menu prompt at the top of the display screen shows a timer that counts from zero to sixty. You can allow zero averaging for the entire period, or cancel the process at any time by pressing the <ENTER> key. This controls the amount of data the flow meter averages to obtain a zero level.

**Using ReversaMatic**

If site conditions do not permit stopping the flow rate at the mounting location, and you do not know the current flow rate, then you can use the ReversaMatic routine to establish the zero flow level. You should perform the ReversaMatic procedure as quickly as possible to ensure that the flow rate remains constant throughout the procedure.

**To invoke ReversaMatic:**

1. To access the [Zero Flow Adjust] option list press <Right Arrow>.
2. Move the cursor to [ReversaMatic]. Press <ENTER> to invoke the routine.
3. The flow meter begins to measure the positive flow rate. "Positive" flow refers to flow moving from upstream sensor location to the downstream sensor location. Note top prompt line shows: **Reversamatic Action**
4. Upon completion, the flow meter beeps and the display screen shows: **Reverse Sensors / Press <ENTER>**
5. Now remove then remount the upstream and downstream sensors in their reversed positions. Mount the Up sensor (without removing its cable) in the Down sensor/cable location. Mount Down sensor with its cable in the Up sensor/cable location. When remounting the sensors, couple them to the pipe properly. Press <ENTER> (after re-installing the sensors).
6. The flow meter measures the negative flow rate briefly, then beeps and repeats the prompt:
7. Now remount the sensors for normal operation (in their original orientation). When remounting sensors, couple them to the pipe properly. Press <ENTER> (after re-installing the sensors).

This completes the ReversaMatic procedure. The system's zero accuracy will be very close to that obtainable using the Actual Zero method, providing flow remained constant during this procedure.

<b>NOTICE</b>
---------------

<b>Preventing Flow Mis-Registration</b>
---

A caution on the use of upper and lower flow limits (used to prevent flow mis-registration) prior to using the Reversal Zero technique (ReversaMatic): If the negative flow rate that the flow meter reads in the step during which the sensors are reversed is more negative than the lower flow limit, the meter will re-register positive and the Reversal Zero cycle will thus be corrupted.
--

Therefore, postpone the installation of upper and lower flow limits until the reversal zero procedure is executed successfully. For pipes that combine large diameters with very high flow velocities, it may be necessary to move the upper and lower flow limits out of the way until the reversal zero is completed. Moreover, pipes of this size frequently have excellent intrinsic zero performance and may not even need zeroing.

### ZeroMatic (optional function)

---

**Note**

ZeroMatic is used in the Reflect Mode only. Invoking ZeroMatic clears any existing fixed zero offset.

---

Use this menu cell to select the ZeroMatic option. If conditions permit the use of the Auto Zero function then the ZeroMatic option can be used as well.

#### To select and enable the ZeroMatic option:

1. In the Install Sensor menu, press <Up Arrow> to scroll to the [Zero Flow Adjust] menu cell.
2. To access the [Zero Flow Adjust] option list press <Right Arrow>.

---

**Note**

If ZeroMatic is not running, the [Actual Zero] menu item will be displayed next to the [Zero Flow Adjust] menu cell.

---

3. Select the [ZeroMatic] menu cell by pressing <Up/Down Arrow> then press <ENTER>.

When the Initial Makeup of ZeroMatic is complete the screen will return to the [Install Sensor] menu and automatically highlight [Operation Adjust], which is the next menu cell.

**To disable the ZeroMatic function:**

1. Select the [Install Sensor] menu cell from the [Dual Path Flow] menu.
2. Scroll down to the [Zero Flow Adjust] menu cell by pressing <Up/Down Arrow>.

---

**Note**

The highlighted [ZeroMatic] menu item is the only indication that ZeroMatic is functioning.

---

3. Invoke the ZeroMatic initial makeup procedure as previously described above.
4. While ZeroMatic initial makeup is running, press <Left Arrow> to abort the process thereby disabling the function.
5. The screen will return to the [Dual Path Flow] menu and highlight the [Operation Adjust] menu cell.

## 5.6 Mounting Temperature Sensors

Temperature is used to normalize the liquids sonic velocity in order to properly determine interfaces and for density determination. Temperature sensors are available in clamp-on style or in insert (Thermowell) style. Refer to the table below. Both styles incorporate 1000 ohm platinum RTD's for high precision.

Table 5- 4 Temperature Sensors

Description	Part Number
Standard clamp-on RTD	7ME39501TA00
Submersible clamp-on RTD (not for FUP1010 or FUE1010)	7ME39501TB00
Standard clamp-on RTD pair for FUE1010 energy system	7ME39501TA10
Insertion style RTD (size 1): 140mm (5.5 in)	7ME39501TJ00
Insertion style RTD (size 2): 216mm (8.5 in)	7ME39501TJ01
Insertion style RTD (size 3): 292mm (11.5 in)	7ME39501TJ02
Insertion style RTD (size 4): 368mm (14.5 in)	7ME39501TJ03
Insertion style RTD pair (size 1) for FUE1010, 140mm (5.5 in)	7ME39501TJ10
Insertion style RTD pair (size 2) for FUE1010, 216mm (8.5 in)	7ME39501TJ11
Insertion style RTD pair (size 3) for FUE1010, 292mm (11.5 in)	7ME39501TJ12
Insertion style RTD pair (size 4) for FUE1010, 368mm (14.5 in)	7ME39501TJ13

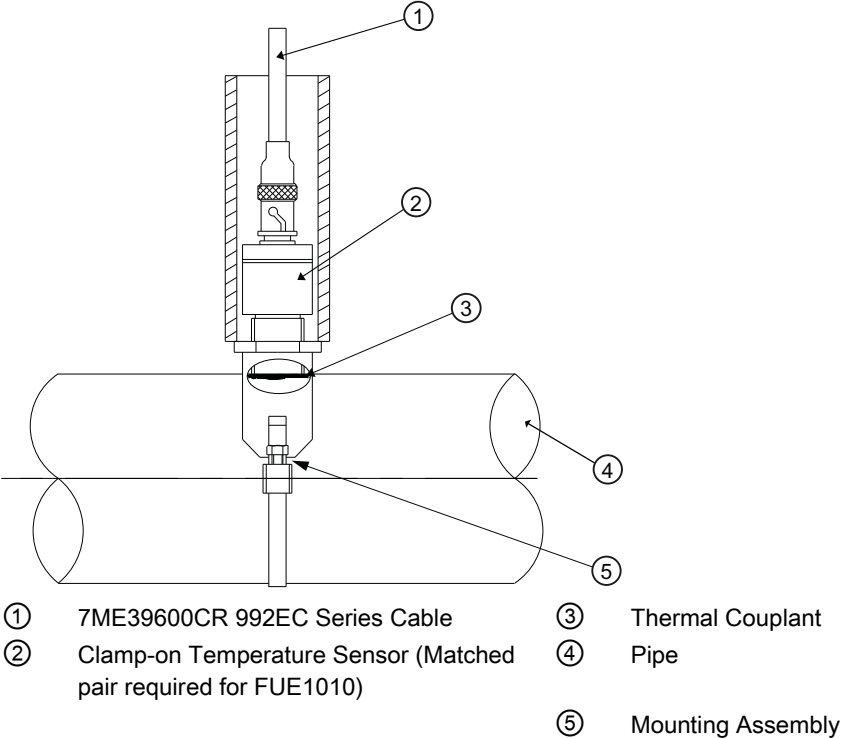
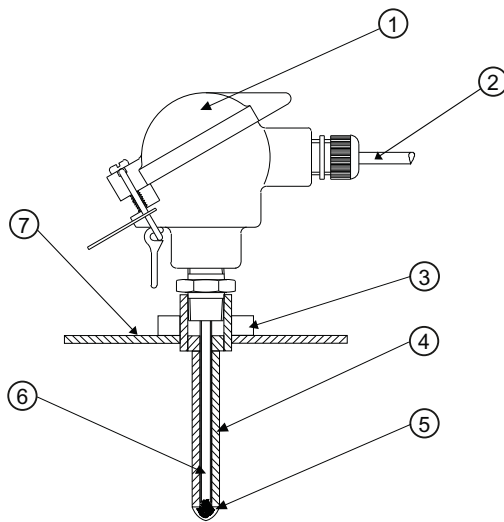

Figure 5-27 Clamp-on Temperature Sensor

### Clamp-on Sensors

Clamp-on style sensors are mounted on the surface of the monitored pipe using series mounting assemblies. Apply a generous quantity of the thermal couplant provided to the tip of the sensor and attach it securely to the cleaned pipe surface with the proper mounting assembly. Temperature measurement anomalies resulting from variations in the ambient conditions can be minimized by insulating the pipe and sensor after installation.



- |  |                                 |
|--|---------------------------------|
| ① Temperature Sensor Connector Head Assembly | ⑤ Thermal Couplant              |
| ② 7ME39600CR 992EC Series Cable              | ⑥ Spring Loaded Sensing Element |
| ③ Threaded Pipe Fitting                      | ⑦ Pipe Wall                     |
| ④ Thermowell                                 |                                 |

Figure 5-28 Insert Temperature Sensor

Insert sensors are designed to be used in pipes equipped with Thermowells. These are spring-loaded, 1/4" diameter sensors with 1/2" NPT integral connection heads, available in several lengths to accommodate a range of pipe sizes.

Proceed to Commissioning (Page 83).

## 5.7 Sensor Wiring

### Connecting Sensors to the Transmitter

1. Open the transmitter top cover. Using a flat blade screwdriver, remove the Cable Strain Relief bracket (see figure below).
2. Observing the upstream and downstream orientation, attach the UP (upstream) and DN (downstream) cables to the sensors and make snug. Attach the other ends to the UP and DN terminals of the flow meter (see figure below).

3. Replace the Cable Strain Relief bracket. Close top cover.
4. Proceed to Commissioning (Page 83).

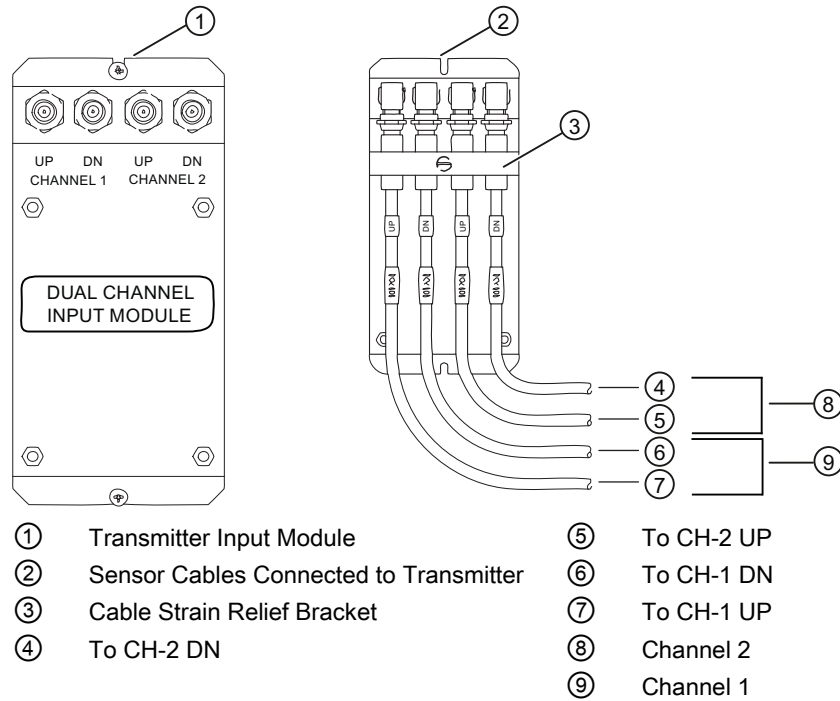

Figure 5-29 Sensor Cable Connections





## Commissioning

### 6.1 General requirements

Before commissioning it must be checked that:

- The device has been installed and connected in accordance with the guidelines provided in chapter 4 "Installing/mounting (Page 29)" and chapter 5 "Connecting (Page 33)"
- Device installed in hazardous location meets the requirements described in "Installation in hazardous location (Page 14)"

### Commissioning

---

**Note**

Refer to Programming the Transmitter (Page 45) if needed.

---

1. Scroll down to [Install Sensor] and press <Right Arrow>.
2. Scroll down to [Install Complete]. Press the <Right Arrow> and select [Install]. Press <ENTER>. The flow meter will go through its drives.

Siemens	2 Channel [1]	SITE1
<b>Install Complete?</b>		
Sensor Model	1011HP-T1	
Sensor Size	D1H	
Sensor Mount Mode	Reflect	
Spacing Offset	Nominal	
Number Index	26	
Spacing Method	Spacer Bar 1012BN	
Ltn Value (in)	7.499	
<b>Install Complete</b>	<b>Yes</b>	
Empty Pipe Set	Channel Not Setup	
Zero Flow Adjust	Channel Not Setup	
<b>Install Sensor</b>		

Figure 6-1 Final Setup

6.1 General requirements

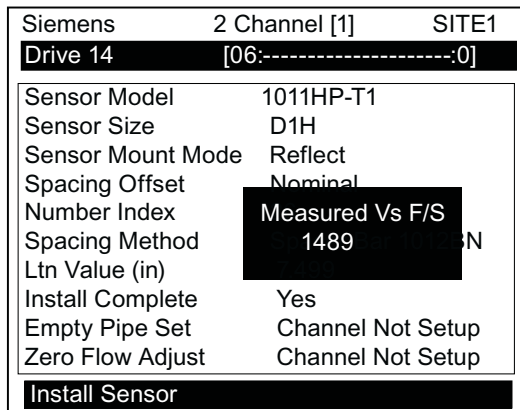
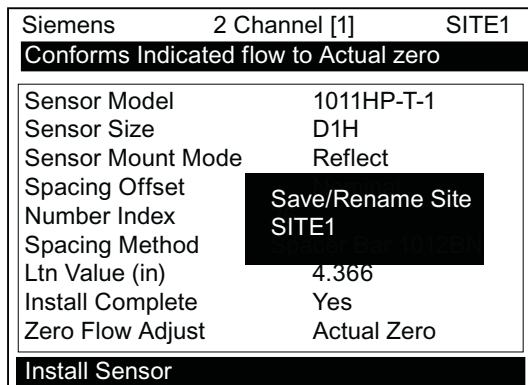
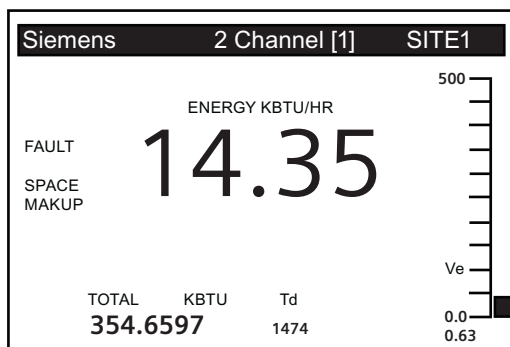

Figure 6-2 Measuring Flow

3. Observe the Measured Vs window and verify a correct sound velocity measurement (if known).
4. Press the <Down Arrow> to accept sound velocity value.
5. Press the <MENU> key.



6. Press the <Right Arrow> and then <ENTER> to save the site data.
7. **The flow meter is now ready to report flow.**



**Note**

Refer to Appendix A I/O Connections and Wiring (Page 167) tables for input/output wiring for data spanning procedures.

## 6.2 Empty Pipe Set

The flow meter performs the MTYmatic routine automatically during its Initial Make-up to establish a standard setting for the Empty Pipe alarm. This process is normally sufficient for setting this parameter. The [Empty Pipe Set] option list allows you to re-invoke MTYmatic, use an Actual MTY routine (if application conditions allow you to empty and refill the pipe) or use the Set Empty routine to set the empty pipe threshold by direct numeric entry.

### Actual MTY Command

If application conditions allow you to empty and refill the pipe, then you may choose to perform the Actual Empty procedure; however, it is not required to do so.

<b>NOTICE</b>
<b>IMPORTANT</b>
NEVER perform the Actual MTY procedure if the pipe can not be emptied.

### To use the Actual MTY command:

1. From [Channel Setup] scroll down to [Install Sensor].
2. Press the <Right Arrow> to access the [Empty Pipe Set] option list.
3. Press the <Down Arrow> to [Actual MTY] then press <ENTER>.
  - **Empty Pipe Press [ENT]** appears on the menu prompt line.

Siemens	2 Channel [1]	ABC
<b>Empty Pipe Press [ENT]</b>		
Sensor Model	1011HP-T1	
Sensor Size	D1H	
Sensor Mount Mode	Reflect	
Spacing Offset	Normal	
Number Index	26	
Spacing Method	Spacer Bar 1012BN	
Ltn Value (in)	7.499	
Install Complete	Set Empty	
<b>Empty Pipe Set</b>	MTYmatic	
Zero Flow Adjust	>Actual MTY	
<b>Install Sensor</b>		

4. Empty the pipe completely, then press <ENTER>.
  - **Fill Pipe Press [ENT]** appears on the menu prompt line.

Siemens	2 Channel [1]	ABC
<b>Fill Pipe</b>	<b>Press [ENT]</b>	
Sensor Model	1011HP-T1	
Sensor Size	D1H	
Sensor Mount Mode	Reflect	
Spacing Offset	Normal	
Number Index	26	
Spacing Method	Spacer Bar 1012BN	
Ltn Value (in)	7.499	
Install Complete	<b>Set Empty</b>	
<b>Empty Pipe Set</b>	MTYmatic	
Zero Flow Adjust	>Actual MTY	
<b>Install Sensor</b>		

5. Refill the pipe completely, then press <ENTER>.

### Using the MTYmatic command

You can repeat MTYmatic (performed during the Initial Makeup) to correct an inaccurate Actual MTY setting if conditions do not allow you to repeat the Actual Empty procedure.

---

#### Note

#### IMPORTANT

Only use the MTYmatic procedure when the pipe is full.

---

### To start MTYmatic:

1. From [Channel Setup] scroll down to [Install Sensor].
2. Press the <Right Arrow> to access the [Empty Pipe Set] option list.

Siemens	2 Channel [1]	ABC
<b>Set Empty Pipe Detection Threshold</b>		
Sensor Model	1011HP-T1	
Sensor Size	D1H	
Sensor Mount Mode	Reflect	
Spacing Offset	Normal	
Number Index	26	
Spacing Method	Spacer Bar 1012BN	
Ltn Value (in)	7.499	
Install Complete	<b>Set Empty</b>	
<b>Empty Pipe Set</b>	>MTYmatic	
Zero Flow Adjust	Actual MTY	
<b>Install Sensor</b>		

3. Move the cursor next to [MTYmatic] press the <Right Arrow>.
4. To invoke MTYmatic press <ENTER>.

### Using the Set Empty command

Use [Set Empty] to enter a number that represents the signal strength level consistent with an empty pipe. [Set Empty] uses non-linear scaling. There is no direct correlation between the number you enter and any standard amplitude unit. If you set the number too low, the meter may not detect a true empty pipe. If you set it too high, it could trigger the empty pipe alarm, suspending flow measurement, even though the liquid is flowing.

#### To enter an Empty Pipe Alarm Threshold:

1. From [Channel Setup] scroll down to [Install Sensor].
2. Press the <Right Arrow> to access the [Empty Pipe Set] option list.
3. Press <Up Arrow> to move the cursor to [Set Empty].

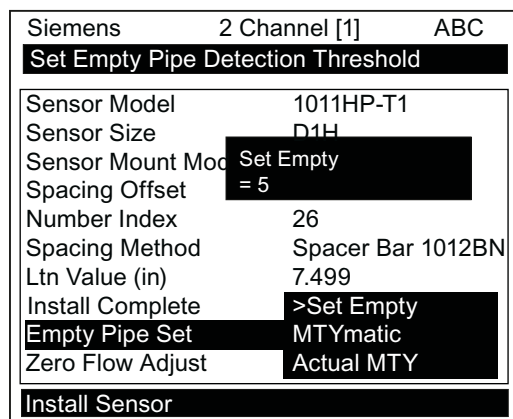

4. Press <ENTER>. The current empty threshold number appears in a pop-up window.
5. Use the numeric keys to type a new Set Empty number.
6. To store the Set Empty number press <ENTER>

## 6.3 Installation Menus

### FUE1010 Installation Menu Chart

Use <Left>, <Right>, <Up> and <Down> arrow buttons to navigate the menu between levels and sub menus.

For example: To navigate to [Sensor Size]:

1. Press <MENU> to return to Level A.
2. Press <Right Arrow> to Level B (2-Chan Energy) then press <ENTER> twice to Level D..
3. Scroll using <Down Arrow> to [Install Sensor].
4. Press <Right Arrow> to Level D.
5. Scroll using <Down Arrow> to [Sensor Size].
6. Press <ENTER> select size from list.

**Note**

Menu items in bold are required entries to establish operation.

Level A	Level B	Level C	Level D	Level E	Level F	Level G
Meter Type	<b>2-Chan Energy</b>	<b>Channel 1/2 Clamp-on</b>		Recall Site	Enter From List	
	<b>2 Path Energy</b>			Channel Enable	No/Yes	
	<b>Ch 1+2 Energy</b>		<b>Channel Setup</b>	<b>Create/Name Site</b>	<b>Enter Site Name</b>	
	<b>Ch 1-2 Energy</b>			Site Security	On/Off	
	<b>Reflexor</b>			Delete Site	Enter/Clear Site Name	
				Save/Rename Site	Enter/Clear Site Name	
			<b>Pipe Data</b>	<b>Pick Pipe Class</b>	<b>Enter From List</b>	
				<b>Select Pipe Size</b>	<b>Enter From List</b>	
				<b>Pipe OD (in)</b>	<b>Numeric Entry</b>	
				<b>Pipe Material</b>	<b>Enter From List</b>	
				<b>Wall Thickness</b>	<b>Numeric Entry</b>	
				Liner Material	Enter From List	
				Liner Thickness	Numeric Entry	
			<b>Application Data</b>	<b>Liquid Class</b>	<b>Select Liquid</b>	<b>Enter From List</b>
					Estimated Vs MS	Numeric Entry
					Viscosity (cS)	Numeric Entry
					Density S.G.	Numeric Entry
				Location	Return/Supply	
				Service	Heating/Cooling/Heat Pump	
				Temp. Range	Enter From List	
				Pipe Config	Enter From List	
				Anomaly Diams	Numeric Entry	
			<b>Install Sensor</b>	<b>Sensor Model</b>	<b>Enter From List</b>	
				<b>Sensor Size</b>	<b>Enter From List</b>	
				<b>Sensor Mount Mode</b>	<b>Enter From List</b>	
				<b>Spacing Offset</b>	<b>Enter From List</b>	
				<b>Number Index</b>	<b>View Only</b>	
				<b>Spacing Method</b>	<b>View Only</b>	
				<b>Ltn Value</b>	<b>View Only</b>	
				<b>Install Complete</b>	<b>No / Install</b>	<b>Select Install</b>
				Empty Pipe Set	Enter From List	

Level A	Level B	Level C	Level D	Level E	Level F	Level G
				Zero Flow Adjust	Enter From List	
			Operation Adjust	Damping Control	Time Average / SmartSlew	
				Energy Deadband	Numeric Entry	
				Deadband Control	Numeric Entry	
				Memory/Fault Set	Fault/Memory	
				Memory Delay (s)	N/A	
			Flow/Total Units	Energy Units	E Rate Units	Enter From List
					E Rate Scale	Enter From List
					Energy Tot Units	Enter From List
					Energy Tot Scale	Enter From List
					Energy Tot Res	Enter From List
					Energy Tot Mode	Enter From List
					CE Method	Enter From List
				Volume Units	Flow Vol. Units	Enter From List
					Flow Time Units	Enter From List
					Flow Disp. Range	Enter From List
					Flow Disp. Scale	Enter From List
					Total Vol. Units	Enter From List
					Totalizer Scale	Enter From List
					Total Resolution	Enter From List
					Totalizer Mode	Enter From List
					Batch/Sample Tot	Numeric Entry
			Span/Set/Cal	Span Data	Enter From List	
				Set Alarm Levels	Enter From List	
				Calib. Flowrate	Intrinsic	
					Kc	
					MultiPoint	
			Display Setup	Select Data	Enter From List	
				Data Display	Enter From List	
				Time Base	Enter From List	
				Stripchart Clear	No/Yes	
			Logger Setup	Logger Mode	Enter From List	
				Logger Data	Enter From List	
				Logger Interval	Enter From List	
				Logger Events	Enter From List	
				Display Logger	Enter From List	
			I/O Data Control	Analog Out Setup	Enter From List	

6.3 Installation Menus

Level A	Level B	Level C	Level D	Level E	Level F	Level G
				Relay Setup	Relay 1,2, 3,4	
				Analog Inp Setup	Enter From List	
			Diagnostic Data	Energy Data	Enter From List	
				Flow Data	Enter From List	
				Application Info	Enter From List	
				Liquid Data	Enter From List	
				Site Setup Data	Enter From List	
				Test Facilities	Enter From List	
				Print Site Setup	No/Yes	
				Site Created:	View Only	mm.dd..yy hh.mm..ss
Meter Facilities	Preferred Units	English				
		Metric				
	Table Setups	Pipe Table	Create/Edit Pipe	Enter From List		
			Delete Pipe	Enter From List		
		Sensor Type	Enter From List			
	Logger Control	Display Logger	Off/Line Wrap No Line Wrap			
		Output Logger	Yes/No			
		Circular Memory	Yes/No			
		Est LogTime Left	View Only			
		Clear Logger	Yes/No			
	Memory Control	Log Memory Left	View Only			
		Memory Map	Yes/No			
		Defragment	Yes/No			
	Analog Out Trim	Trim Io1	Operate / Trim @ 4mA			
		Trim Io2	Operate / Trim @ 4mA			
		Trim Vo1	Operate / Trim @ 2V			
		Trim Vo2	Operate / Trim @ 2V			
		Trim Pgen1	Operate / Trim @ 1kHz			



Level A	Level B	Level C	Level D	Level E	Level F	Level G
		Trim Pgen2	Operate / Trim @ 1kHz			
	RTD Calibrate	Ch1 Ts-RTD1	Factory / User Cal			
		Ch1 Tr-RTD2	Factory / User Cal			
		Ch2 Ts RTD3	Factory / User Ca			
		Ch2 Tr RTD4	Factory / User Ca			
	Clock Set	Date (MM.DD.YY)	Edit Date			
		Time (HH.MM)	Edit Time			
	RS-232 Setup	Baud Rate	Enter From List			
		Parity	Enter From List			
		Data Bits	7/8			
		Line Feed	Yes/No			
		Network ID	Numeric Entry			
		RTS Key Time	Enter From List			
	Backlight	Enter From List				
	System Info	Version	View Only			
		Reset Data/Time	View Only	mm.dd.yy.hh.mm.ss		
		Op System P/N	View only			
		Checksum	View Only			
		Code	View only			
		System Time	View Only	mm.dd.yy.hh.mm.ss		
Language	Enter From List					



## Functions

### 7.1 Selecting Flow Units

#### Selecting Flow units

The [Flow/Total Units] menu is available after selecting a meter type and measurement channel. Use the [Flow/Total Units] menu to select energy and volumetric flow units and an associated time base for the flow rate and total outputs. After making your selections, a view-only menu cell shows the resultant scaling. Another menu cell lets you adjust the output resolution by selecting a display range.

#### Selecting Flow/Total Units

The [Flow/Total Units] option list allows you to select the rate units the flow meter uses to report energy or volumetric flow. The energy unit default is [E Rate Units]. The default in English units for liquid is [Gallons].

#### To select energy units:

1. Press the <MENU> key and [Meter Type] will be highlighted.
2. Press the <Right Arrow> to [Dual Path Flow] and then press <ENTER>.
3. The [Dual Path Flow] menu will appear with [Chan/Path Setup] menu item highlighted.
4. Scroll down to the [Flow/Total Units] menu and press the <Right Arrow> to select the [Energy Units] menu.

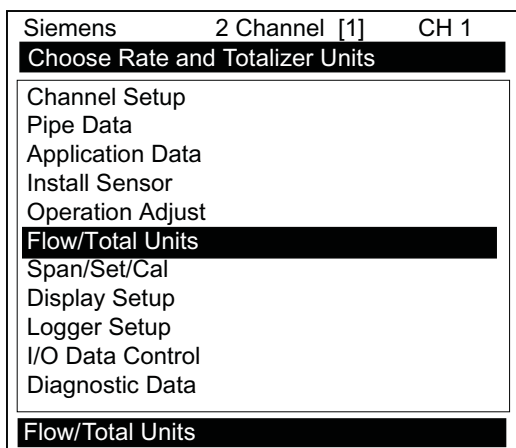

7.1 Selecting Flow Units

5. Press the <Right Arrow> to select [Energy Units].

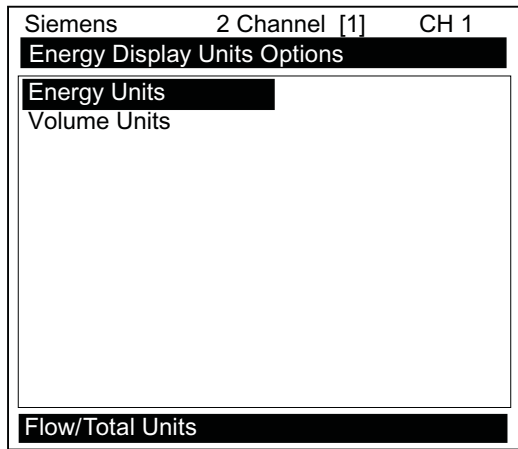

6. Press the <Right Arrow> to select the option list and use the <Up/Down Arrows> to select the desired units.

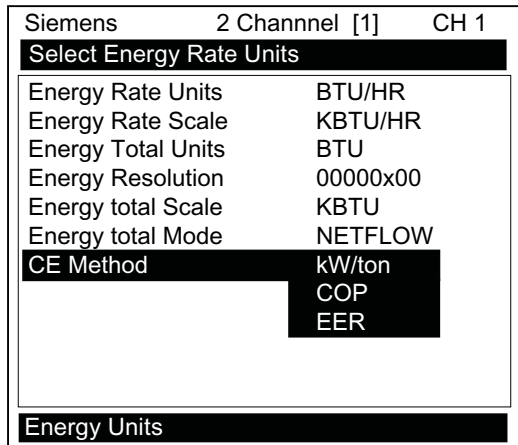

7. Press <ENTER> to store selection.

**Totalizer Modes**

The Totalizer function operates in any of the modes listed below:

Table 7- 1 Totalizer Modes

Mode	Flow Direction	Notes
POSFLOW	positive flow	Accumulates flow in positive direction only
NEGFLOW	negative flow	Accumulates flow in reverse direction only
NETFLOW	positive or negative flow	Adds to positive total; subtracts from reverse total

**Note**

NETFLOW (default) is best for applications where there may be zero flow for long periods. It minimizes false Totalizer register increments due to data scatter. Press the <Down Arrow> to accept the default setting.

**Selecting Totalizer modes**

1. Press the <MENU> key and [Meter Type] will be highlighted.
2. Press the <Right Arrow> to [Dual Path Flow] and then press <ENTER>.
3. The [Dual Path Flow] menu will appear with [Chan/Path Setup] menu item highlighted.
4. Scroll down to the [Totalizer Mode] menu and press the <Right Arrow> to select the Totalizer Mode option list.

Siemens 2 Channel [1] CH 1	
Choose positive, negative or net total	
Flow Vol. Units	Gallons (US)
Flow Time Units	MIN
Flow Disp. Range	Autorange
Flow Disp. Scale	GAL/MIN
Total Vol. Units	Gallons (US)
Totalizer Scale	KGAL
Total Resolution	NEGFLOW
Totalizer Mode	>NETFLOW
Batch/Sample Tot	POSFLOW
Flow/Total Units	

5. Press the <Up/Down Arrows> to select the desired mode.
6. Press <ENTER> to store selection.

**Totalizer Mode Controls**

From the RS-232 serial port all of the Totalizer commands listed below can be executed using PC keyboard function keys via VT100 terminal key emulation.

**Note**

Si-Ware or HyperTerminal should be in the Data Display mode when invoking the function keys referenced in the table below. Use the key sequence <Ctrl L> to display the Data Display mode.

### Communications Setup

Connect the flow meter to your PC. Refer to Appendix A for communications setup procedures, if needed.

1. Access Si-Ware or, if using a PC, access HyperTerminal from the PC [Programs] menu, then select [HyperTerminal].
2. In [Connection Description] dialog box, enter a connection name (e.g. FUE1010). Click [OK].
3. In [Phone Number] dialog box, select [Direct to COM 1 (or COM 2)]. Click [OK] to select.
4. In [Properties] dialog box, enter RS-232 parameters. Click [OK].
5. At terminal screen, click [File]. Select [Properties].
6. Select [Settings] tab. At [Emulation] box, select [VT-100].
7. Select [ASCII Setup]. In [ASCII Sending] uncheck boxes. In [ASCII Receiving] check [Append line feeds to incoming line ends.]. Click [OK].
8. At the Terminal screen, press <ENTER> and the Data Display mode appears.
9. If not, to enter the Data Display mode type MENU and then press <Ctrl L>.

Table 7- 2 Totalizer Controls (the "n" in <Fn> = channel number)\*

Key	PC #	Command	Description
F1 F2 F3 F4	1	CLRTOT (also clears overflow)	Resetting the Totalizer registers clears all total data accumulated during operation. Note: In Dual Path mode, the Totalizer operates only on the virtual system channel (Ch 3). Therefore in this case, the CLRTOT trigger would be <F3> <1>. Commands that can be invoked from Si-Ware or HyperTerminal: Terminal Command: CLRTOT 1.
F1 F2 F3 F4	2	NOTOT (Totalizer Freeze)	Invoking the NOTOT command disables the Totalizer. Totalization will not resume until you repeat the <Fn> <2> key sequence. When you activate NOTOT, an N precedes the TOTAL symbol (i.e. [NTOTAL]) on the LCD Screen. Commands that can be invoked from Si-Ware or HyperTerminal: Terminal Command: NOTOT 1 = Stop Totalizer Terminal Command: NOTOT 1 = Start Totalizer
F1 F2 F3 F4	3	LAPTOT (Totalizer snapshot)	The LAPTOT command freezes the Totalizer screen display. However, the flow meter will continue to update its internal registers. The flow meter will show the current total when you repeat the <F1>< 3> key sequence. When you activate LAPTOT, an L precedes the TOTAL symbol (i.e., [LTOTAL]) on the HyperTerminal screen.
F1 F2 F3 F4	4	CLEAR (Batch/Tot register)	Clears the Batch/Sample Totalizer register. The flow meter maintains a separate Totalizer register for Batching or Sampling applications but cannot be accessed directly. It is used for relay control only. If you assign the system relay to this function, a momentary (200 ms) relay pulse occurs whenever the BATCHTOT register accumulates a specified liquid quantity. In the [Batch/Sample Tot] menu cell the required total flow volume is entered to activate the relay,. This numeric entry must reflect the selected flow total units. The [Totalizer Scale] menu cell shows the applicable flow total units. The sign of the Batch/Sample Total determines positive or negative accumulation.
F1 F2 F3 F4	5	CLEAR (Makeup Latch)	Clears the Makeup Latch. Refer to the Span Data menu [Set Alarm Levels] and then the [Makeup Latch] On / Off option.

\*Use the <F1> key as the "Lead-in command" for 4-Path Totalizer operations.

## 7.2 Span Data

The [Span Data] menu allows you to set 0% and 100% output limits for energy rate (Ve), volumetric flow (Vfo), absolute flow (Vfab) and sonic velocity (Vs). Each menu cell shows appropriate rate units and time base. If you change flow rate units after spanning the system, the computer automatically updates the output data setup to reflect the change. Span limits apply to both the analog outputs and the on-screen stripchart. The flow outputs operate as follows:

<p>Ve <i>Spanned energy rate:</i></p>	<p>The entries establish the Ve span. The Max Energy Flow menu cell sets 100% of span while the Min Energy Flow menu cell sets 0% of span. Use signed numbers for bi-directional spanning. Note that negative (reverse) energy is always lower than positive energy, whatever its absolute magnitude. For example, for a flow measurement range of -30 KBTU to +10 KBTU, the 4mA span will be -30 KBTU, and the 20mA span will be +10 KBTU.</p>
<p>Ts, Tr, Td <i>Spanned Supply, Return Delta Temperature:</i></p>	<p>Use these menu cells to span the two temperatures, Ts and Tr and the computed temperature difference, Td. Use signed numbers for bidirectional spanning.</p>
<p>Vfo <i>Spanned Volumetric Flowrate:</i></p>	<p>The minimum and maximum flow rate entries establish the Vfo span. The Max Flow menu cell sets 100% of span. The Min Flow menu cell sets 0% of span. Use signed numbers for bi-directional spanning. Note that negative (reverse) flow always is lower than positive flow, whatever its absolute magnitude. For example, for a flow measurement range of -30 GPM to +10 GPM, the 4mA span will be -30 GPM, and the 20mA span will be +10 GPM.</p>
<p>Vfab <i>Spanned Absolute Volumetric Flow Rate:</i></p>	<p>Vfab is the absolute magnitude of the volumetric flow rate (Vfo). There are no menu cells provided to span this output. Vfab shares the Vfo span entries. The Vfab minimum span is always zero. The maximum span for Vfab is the largest absolute value of either the min. or the max. flow rate (Vfo) entries. For example, a span between +10 GPM and -30 GPM, spans the Vfab output from 0 GPM to 30 GPM.</p>
<p>Vs <i>Spanned liquid sonic Velocity:</i></p>	<p>Vs is the sonic velocity in meters-per-second (m/s) of the flowing liquid. The min. and max. Vs entries establish the Vs span. Max Vs (m/s) defines 100% of span. The Min Vs (m/s) defines 0% of span.</p>



Maximum span values represent:	Minimum span values represent:
100% of span Current output of 20mA Voltage output of 10 VDC Pulse output of 5000 Hz	0% of span Current output of 4mA Voltage output of 0 VDC Pulse output of 0 Hz

**To change the default Span Data settings:**

1. At [Meter Type], press <Right Arrow> to [Dual Path Flow] and press <ENTER>.
2. At [Chan/Path] press <Right Arrow> to <Clamp-on> and press <ENTER>.
3. At [Clamp-on] menu scroll down to [Span/Set/Cal] and press <Right Arrow>.
4. Highlight [Span Data] and press the <Right Arrow>.

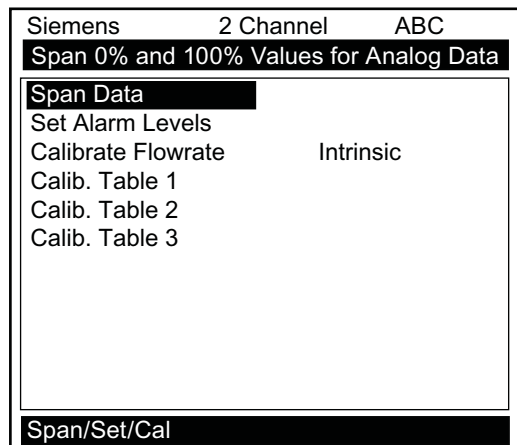

5. Highlight [Max Energy Flow] and press <Right Arrow> to. Input 100% flow rate numeric data for 20mA. Press <ENTER> to store data.
6. Scroll down to [Min Energy Flow]. Press <Right Arrow> to input 0% flow rate numeric data for 4mA. Press <ENTER> to store data.

Siemens	2 Channel	ABC
<b>Set 100% (20 mA) energy rate</b>		
<b>Max Energy Flow</b>	=	0.00
Min Energy Flow		0.00
Max Flow		1848
Min Flow		1000
Max Ts		50.0
Min Ts		25.0
Max Tr		60.0
Min Tr		40.0
Max Td		50.0
Max Vs MS		2000
Min Vs MS		1000
<b>Span Data</b>		

① Input numeric energy flow data here.

### 7.3 Logger Control

#### Logger Control Menu

The Logger Control menu in the [Meter Facilities] menu provides the Logger controls for the flow meter measurement channels and paths. It allows the user to select data items/alarm events, a logging interval and a destination for Logger reports. While the Logger Setup menu is measurement channel/path specific, this Logger Control menu provides global control functions. This means that the settings made here apply to all measurement channels/paths, meter types, operating modes, etc. This is possible because the flow meter stores logged data in a single file.

The [Est LogTime Left] menu view-only menu cell shows an estimate of the hours and minutes of logging time remaining. For convenience sake, the Display Logger command is essentially a duplicate of the menu cell in Logger Setup. It sends Logger data to the graphic screen with or without line wrapping. The Output Logger command sends data to an external device via the RS-232 serial port. The Clear Logger command erases the entire Logger file.

1. From the Meter Facilities menu access the [Logger Control] menu by pressing the <Right Arrow>.
2. Scroll down to [Logger Control]. Press the <Right Arrow> to access the [Logger Control] menu option list.

Siemens	2 Channel [1]	CH 1
<b>Datalogger Control</b>		
Preferred Units	English	
Table Setups		
<b>Logger Control</b>		
Memory Control		
Analog Out Trim		
RTD Calibrate		
Clock Set	06.23.09 12.46.56	
RS-232 Setup	38400 Odd [0]	
Backlight	On	
System Info		
<b>Meter Facilities</b>		

Table 7- 3 Logger Control Menu Option List

Logger Control	Display Logger	Off Line Wrap No Line Wrap
	Output Logger	No Yes
	Circular Memory (Available for Multi-Path units only)	No Yes
	Est LogTime Left	--:--
	Clear Logger	No Yes

### Display Logger

This menu cell allows you to send the Logger contents to the display screen. This command is effective only after a successful install. You can set the report to scroll on the screen with or without line-wrap. Selecting line wrap, forces a line feed after approximately 40 characters. In addition, you have to enable datalogging and then select items in the Logger Setup menu. Note that this command transmits the data from both channels/paths.

**To send Logger contents to the display screen:**

1. Press <Right Arrow> to access the [Display Logger] option list.

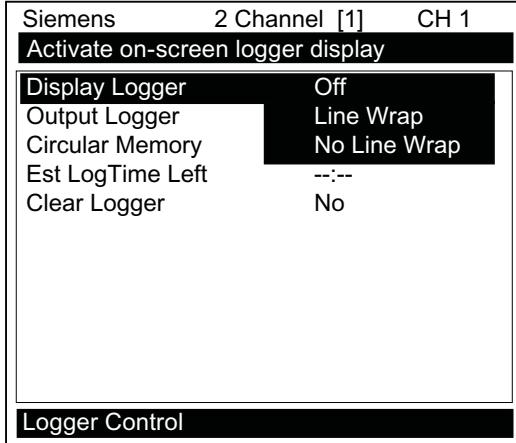

2. Scroll cursor to either [Line Wrap] or [No Line Wrap] by pressing <Up/Down Arrow>.
3. To view Logger contents press <ENTER>.
4. To return to [Logger Control] press <MENU>.

**Output Logger**

This menu cell allows you to send the Logger contents to an external device (usually a computer or printer) via the flow meter's RS-232 Serial I/O port. This command is effective only after a successful install. In addition, you have to enable datalogging and select data items in the [Logger Setup] menu.

The flow meter interfaces with most serial printers or personal computers for Logger printouts. You must use the proper cabling between the flow meter and the external device. In addition, you must configure the RS-232 Setup correctly. You should turn off the Logger function before you transmit an extensive printout. This will avoid contaminating the printout with new Logger data. Logger reports are sequential ASCII text files.

**To send Logger contents to the RS-232 Serial Port:**

1. Check the flow meter-to-external device connections and your RS-232 Setup parameters (see RS-232 Setup menu).
2. To access the [Output Logger] option list press <Right Arrow>.
3. Scroll the cursor to [Yes] by pressing <Up/Down Arrow>.
4. To transmit Logger contents to external device via the serial port press <ENTER>.
5. To stop printout press <Left Arrow>.

## Circular Memory

In its default mode, the Logger collects data until its memory becomes full. At that time the flow meter suspends datalogging and cannot resume until the Logger memory is cleared (see Clear Logger command). Circular Memory allows the Logger to "write over" its oldest records when memory reaches full capacity. If you enable [Circular Memory], you are assured of always collecting the most recent data. But also remember that you will lose the oldest Logger reports and that further invoking of [Circular Memory] deletes the current contents of the Logger.

### To setup and enable Circular Memory:

1. The Logger Mode menu must have the [Memory] menu cell selected.
2. Logger items must be selected (e.g., Site ID, Date, Time, etc.).
3. All active channels/paths in the Channel Setup menu must be disabled. To disable active channels, select the [Channel Enable] menu cell and then [No].
4. In the Logger Control menu, select [Circular Memory].
5. Press <Right Arrow> to access the [Circular Memory] option list.
6. Move the cursor to [Yes] by pressing <Up/Down Arrow>.
7. To store selection press <ENTER>.
8. Lastly, re-enable the channels/paths that you disabled earlier to begin logging.

## Est LogTime Left

Est LogTime Left is a "view-only" menu cell that shows an estimate of the amount of Logger time remaining in hours and minutes. This menu cell becomes active after you enable datalogging. Selecting [Circular Memory] and/or event-based datalogging (see Logger Setup), blanks the [Est LogTime Left] field and is based on the log interval and data selections made in the Logger Setup.

## Clear Logger

If you use the Logger in its default mode, eventually you will use all the memory available for Logger storage. When this occurs, you will not be able to log more data until you free up the memory. The [Clear Logger] command erases ALL stored Logger data. Therefore, you should evaluate the currently stored data, and print any valuable information before using this command.

---

### Note

Saved Sites also consume Logger RAM.

---

### Clearing Logger Memory

1. To access the [Clear Logger] option list press <Right Arrow>.
2. Move the cursor to [Yes] by pressing <Up/Down Arrow>.
3. To clear the memory press <ENTER>.

## 7.4 Operation Adjust Menu Settings

### Introduction

The Operation Adjust menu becomes available after picking a meter type and measurement channel. It is recommended that you use it after the sensors are installed and operating to "fine-tune" the meter's output characteristics.

Each application presents different data display and output requirements due to unique pipe and liquid conditions. Use the [Operation Adjust] menu to match flow meter operation to the site. You can set damping controls for the primary flow rate output. You can define a Deadband, (usually a very low flow rate), below which the flow output will be forced to zero. You can also select the flow meter response to a continuous Fault condition.

### Damping Control

The flow meter provides two different data output filter types, Time Average and SmartSlew. Time Average (recommended) integrates the instantaneous flow rate over a selectable time period. Use the Time Average function when stability in flow reading is essential. A value entered (in seconds) sets the time it takes the flow meter to respond to a rate change. The default is 10 seconds. Enter any amount of time up to 60 seconds maximum.

SmartSlew performs data scatter damping during steady flow periods while maintaining the ability to respond to changing flow rates. SmartSlew values range from [1 to 9]. Pick a higher number to slow flow meter response to a rate change.

### Setting the Time Average (default):

1. From the [Dual Path Flow] menu scroll to the [Operation Adjust] menu and press <Right Arrow>.
2. At the [Damping Control] menu press the <Right Arrow> and move the cursor down to [Time Average].
3. To enable Time Average entry press <Right Arrow>.

Siemens 2 Channel [1] CH 1	
Select SmartSlew or TimeAvg Damp	
<b>Damping Control</b>	<b>Time Average</b>
Energy Deadband	0.00
Deadband Control	0.00
Memory/Fault Set	Memory
Memory Delay <s>	120
Operation Adjust	

4. Use the numeric keys to type the new Time Average setting.
5. To register the new value press <ENTER>.

### Setting SmartSlew :

1. From the [Dual Path Flow] menu scroll to the [Operation Adjust] menu and press <Right Arrow>.
2. At the [Damping Control] menu press the <Right Arrow> and move the cursor down to [SmartSlew].
3. To access SmartSlew option list press <Right Arrow>.
4. Scroll the numeric list to the desired choice by pressing <Up/Down Arrow>.
5. To register the new value press <ENTER>.

### Deadband Controls

The meter has two separate and independent deadband controls. One deadband control is for energy flow rate and the other is for volume flow rate. Follow the instructions below to set each deadband control as desired.

Use the Deadband Control to instruct the flow meter to report zero flow if the flow rate falls below a specified level (usually a very low rate). It will prevent the possibility of data scatter (a natural result of digital computation) from causing false Totalizer accumulation during long non-flowing periods. Inspect the actual data scatter during zero flow conditions to find the proper Deadband setting for your application.

---

#### Note

The units of the numerical entry (e.g. kGal, BTU/HR, etc.) are the same as the Display Units for each item of energy flow or volume flow.

---

Note that each deadband setting is independent of the other. For example, if the Volume flow rate falls below the deadband setting for the volume flow, the Volume flow rate will be reported as zero. However, if the Energy flow rate remains above the deadband setting for the energy flow rate, the system will continue to report the measured energy rate (i.e. it will not be zero.).

**To edit Deadband default setting (0.000):**

1. From the [Dual Path Flow] menu scroll to the [Operation Adjust] menu and press <Right Arrow>.
2. Scroll to the [Energy Deadband] or [Deadband Control] menu.
3. Press <Right Arrow> to enable numeric entry.
4. Use the numeric keys to type in the desired rate (using selected flow rate units).
5. To register the new value press <ENTER>.

**Memory/Fault Set**

Certain situations will interrupt data production (e.g., an empty pipe or excessive aeration). Use Memory/Fault Set to select the flow meter response to such an interruption. The Fault setting (default) will zero the flow rate output and declare an alarm on a flow display screen, Datalogger report and an assigned relay output.

For some applications, occasional temporary Fault conditions may be a normal part of the process and would not require an alarm response. The flow meter offers a Memory operating mode to support such an application. Memory Mode suspends the flow meter Fault response by preventing the flow outputs from dropping to zero for the interval specified in the Memory Delay menu cell. During the Memory duration, the flow meter will maintain the last valid flow reading measured before the onset of the fault condition. The default Memory Delay is 60 seconds. You may select any duration from 3 to 604,800 seconds (one week).

**Selecting Memory Mode**

1. From the [Dual Path Flow] menu scroll to the [Operation Adjust] menu and press <Right Arrow>.
2. Scroll to the [Memory/Fault Set] and press <Right Arrow> to access option list.
3. Move the cursor down to [Memory] by pressing <Up/Down Arrow>.
4. To make selection press <ENTER>.
5. This moves the highlight to [Memory Delay (s)].

**Memory Delay (s)**

Selecting [Memory Delay <s>] activates the suppressed [Memory Delay] menu cell. It allows you to specify the number of seconds that the flow meter maintains its last valid flow reading. When the memory delay expires, it triggers the fault alarm response described previously.

**Setting Memory Delay**

1. To enable numeric entry press <Right Arrow>.
2. Use the number keys to type the delay in seconds.
3. To register the new value press <ENTER>.



## Reflexor Zero/Fault Option (Reflexor Mode Only)

---

### Note

The [Zero/Fault set] menu option only appears on the display if the selected channel is the Reflexor mode.

---

The Reflexor declares a Fault when the receive signal drops below the Doppler detection threshold. To change the Reflexor response to a Zero Flow indication rather than a Fault, select [Zero] in the [Zero/Fault Set] menu option. Note the following:

1. FAULT – When selected the system will declare the Reflexor channel to be in Fault and the flow meter will indicate "F" on the display screen. Note that when a new Reflexor channel is created the [Fault] option is the default mode. Also note that the sum (or difference) channel will also be declared to be in Fault.
2. ZERO – When selected the Reflexor channel will be declared to be at Zero Flow instead of in Fault and the flow meter will indicate 0.00 on the display screen.

## 7.5 Setting Relays

### Relay Functions

Use the [Relay Setup] menu to assign a function to channel relays. The flow meter supports two types of relay outputs, Alarm Relay and Pulse Relay. Alarm Relay outputs operate in "fail-safe" mode. The relay(s) are energized under normal conditions - an alarm condition causes the relay(s) to de-energize until the alarm clears. The Pulse Relay output supports Totalizer and batch relay functions, with an output pulse width of approximately 200 ms; maximum activation rate is 2.5 pulses per sec. If Totalizer pulses exceed this rate, excess pulses are stored in an overflow register. This allows the relay to "catch up" when flow decreases enough.

---

### Note

Using the <F1> key (Totalizer clear command) also clears all channel Totalizers plus the overflow register described in the last paragraph.

---

### Relay 1 and 2 Function Assignments

The flow meter, depending upon the model, provides at least two alarm relays. Please refer to the Appendix for wiring details. Relays respond to any of the alarm conditions or data functions included on the Relay Option List.

7.5 Setting Relays

Table 7- 4 Relay Option List

Not Used	Not Active
Power Off	Power Off alarm occurs when power fails.
High Flow	Flow rate exceeds high flow setpoint.
Low Low	Flow rate exceeds or falls below flow setpoint.
Flow Alarm	Flow rate exceeds or falls below flow set points.
Fault Alarm	System loses receive signal (all paths in fault).
Soft Fault	Fault condition - memory mode active.
Spacing	Sensor spacing needs adjusting.
Empty	Empty pipe alarm.
Aeration	Aeration percentage exceeds alarm set point.
Reverse Flow	Flow is in negative direction.
BatchTot	Batch/Sample total advances.
Pos Total	Positive total volume advances 1 digit.
Neg Total	Negative total volume advances 1 digit.
High Energy	High Energy value relay setpoint.
Low Energy	Low Energy value relay setpoint.
Energy Postot	Positive energy totalizer advances by 1 digit.
Energy Negtot	Negative energy totalizer advances by 1 digit.
Td	Temperature diference relay setpoint.
Ts	Supply temperature relay setpoint.
High CE	High Chiller Effeciency value relay setpoint.
Low CE	Low Chiller Effeciency value relay setpoint.

Assigning functions to Relay 1:

1. From the [Dual Path Flow] menu scroll down and highlight [I/O Data Control].
2. Press <Right Arrow> and scroll down to [Relay Setup].

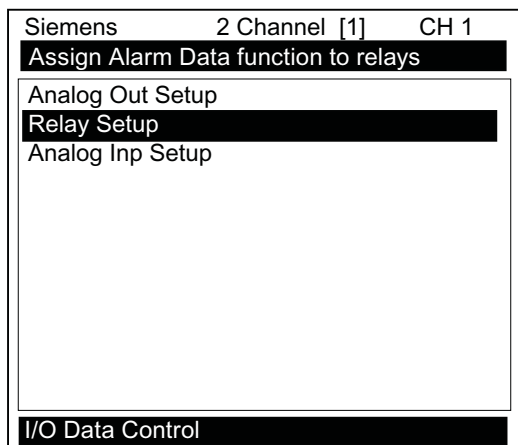

3. To access the [Relay Setup] option list press <Right Arrow>.

4. Move the cursor to the desired Relay assignment by pressing <Up/Down Arrow>.

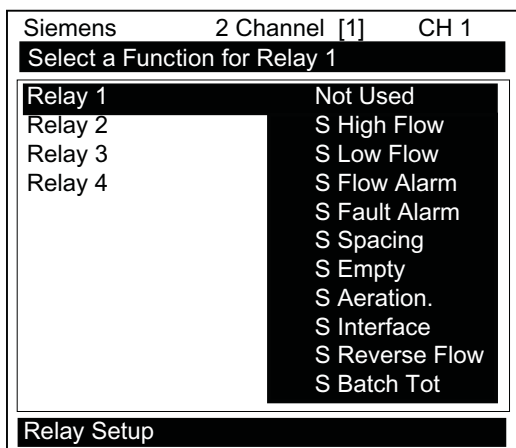

5. To store selection press <ENTER>. Repeat procedure for all other relays.

## 7.6 Memory Control

### Introduction

Memory Control is a reference menu that shows the amount of bytes of data memory left. The data memory capacity depends on the number and complexity of the site setups stored in memory and the size of the current Datalogger file.

The [Memory Control] menu is located in the [Meter Facilities] menu.

Table 7- 5 Memory Control Menu

Log Memory Left→	XXXXXXXX
Memory Map→	No Yes
Defragment→	No Yes

### Log Memory Left

This view only menu cell shows the minimum remaining number of characters available for Datalogger and site storage. When the Datalogger is enabled for circular mode, the meter allocates all memory left except for two conventional empty sites required for Datalogger use.

To view the amount of data memory bytes available press <Right Arrow>.

### Memory Map

Selecting [YES] for this item enables a snapshot display of current memory usage. In this display, the asterisk indicates a used memory block, a space indicates a free block, while a dash character indicates unused filler.

### Defragment

Selecting [YES] for this item consolidates memory data blocks into contiguous storage; collapsing the filler regions. You may be able to use an additional block for site or Datalogger storage as a result. Use this command if you seem to be out of memory even though the [Log Memory Left] item indicates free capacity.

## 7.7 Analog Out Setup

The flow meter provides current, voltage and pulse-rate analog outputs. The [Analog Out Setup] menu allows you to assign data functions for these signals. The transmitter terminal strip contains the analog output terminals.

Table 7- 6 Analog Outputs

<b>Io</b> (Isolated Current)	4 to 20mA varies in proportion to an assigned data function.
<b>Vo</b> (DC Voltage)	0 to 10 VDC varies in proportion to an assigned data function.
<b>Pgen</b> (TTL Logic)	0 to 5000 Hz varies in proportion to an assigned data function.

Table 7- 7 Analog Out Setup Data Categories

<b>Vfo</b>	Spanned volumetric/mass flow.
<b>Vfo2</b>	Additional Spanned volumetric/mass flow.
<b>Vf</b>	Spanned unsigned flow magnitude.
<b>Vs</b>	Spanned liquid sonic velocity.
<b>Valc</b>	Receive signal amplitude.
<b>Vaer</b>	Relative degree of liquid aeration/cavitation.
<b>Ve</b>	Spanned instantaneous energy rate.
<b>Ts</b>	Spanned supply temperature.
<b>Tr</b>	Spanned return temperature.
<b>Td</b>	Spanned temperature difference (delta).
<b>CE</b>	Spanned Chiller efficiency rate.

## Io Output Functions

### Note

4-20mA outputs also provide a fault indication by dropping to 2mA if assigned to flow rate and under fault conditions.

### Assigning a function to the current output:

1. From the [Chan/Path Setup] menu scroll to [I/O Data Control].
2. Press <Right Arrow> to highlight the [Analog Out Setup] menu.

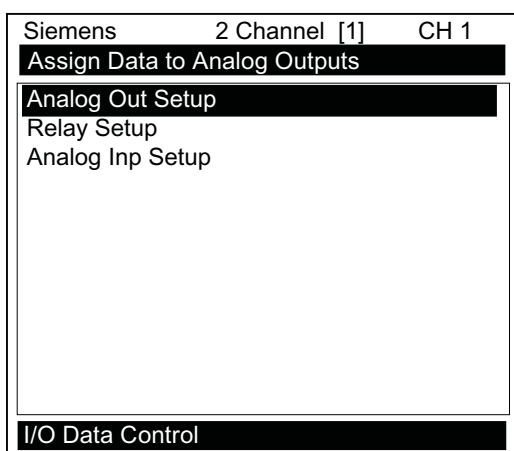

3. Press <Right Arrow> twice to access the [Io] option list.
4. Move the cursor to the desired data function by pressing <Up/Down Arrow>.

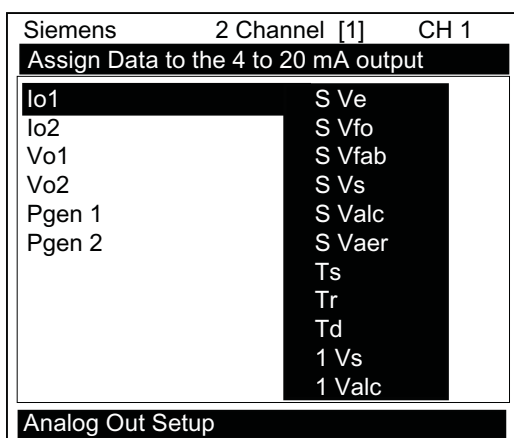

5. To store selection press <ENTER>.

### Vo Output Functions

The Vo analog output is a 0-10 VDC signal that varies linearly in relation to a selected function.

#### Assigning a function to the voltage output:

1. From the [Analog Out Setup] menu, press <Right Arrow> to access the [Vo1] option list.
2. Move the cursor to the desired data function by pressing <Up/Down Arrow>.
3. To store selection press <ENTER>.

---

#### Note

Refer to drawing 1010N-7-7 for Analog output connections.

---

### Pgen Output Functions

The Pgen analog output is a buffered TTL-compliant pulse rate signal that varies linearly from 0-5000 Hz in relation to a selected data function.

#### Assigning a function to the Pgen output:

1. From the [Analog Out Setup] menu, press <Right Arrow> to access the [Pgen] option list.
2. Move the cursor to the desired data function by pressing <Up/Down Arrow>.
3. To store selection press <ENTER>.

## 7.8 Analog Input Setup

**Note**

Some versions of the energy flow meter have the ability to read analog input signals. The [Analog Inp Setup] menu cell is not displayed if the operating system of your model does not include this facility.

The optional Analog Input Setup function assigns an active analog input to a measurement channel/path. The flow meter provides two DC current input ports for Dual Channel/Dual Path units. These ports can be assigned to represent supply temperature, return temperature or power consumption (see table below). The DC current input ranges from a zero level of 4mA to a full scale of 20mA. The [Analog Inp Setup] menu cell allows you to enable this port and then span it to any desired scaling (see table below).

**Note**

Refer to the Installation Drawings or I/O Module markings for the locations of these inputs and wiring procedures.

I/O Data Control	Analog Inp Setup	lin1	Input	Off	
				Aux	
				Ts Deg F	
				Ts Deg C	
				Tr Deg F	
				Tr Deg C	
				Pc kW (used with CE Method only)	
				4mA	Numeric entry
				20mA	Numeric entry
		lin2	Input	Same as lin1	

The flow meter recognizes the first analog input variable that is assigned to any given parameter and ignores any subsequent input with the same assignment. For example, if lin1 and lin2 are both assigned to represent Supply Temperature (Ts Deg F) the flow meter will only use the Supply temperature input from lin1.

### Setting the Analog Current Input

The DC current input port must be enabled first. From the [Analog Inp Setup] menu proceed as follows:

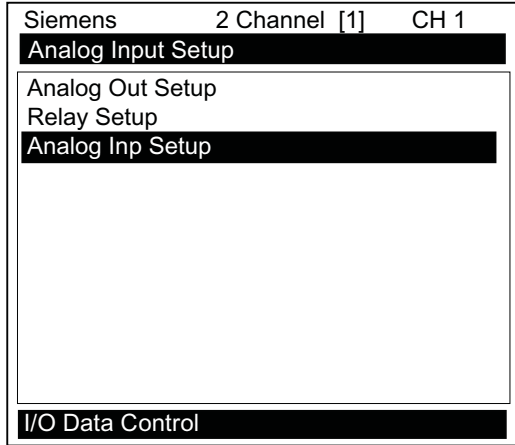

1. Access the [lin1] option list by pressing the <Right Arrow> twice.

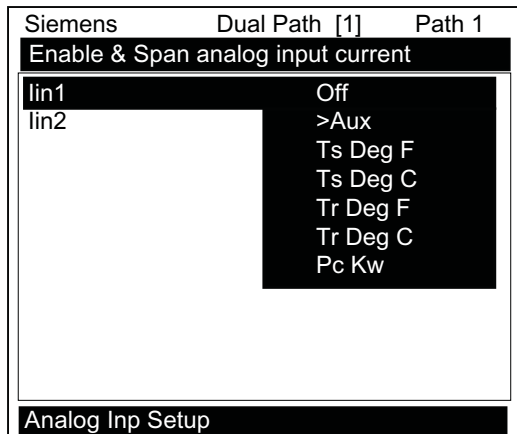

2. Move the cursor down to [Aux] by pressing the <Down Arrow> and then press <ENTER>. This enables the port to receive an input current. The cursor moves to [4 mA].

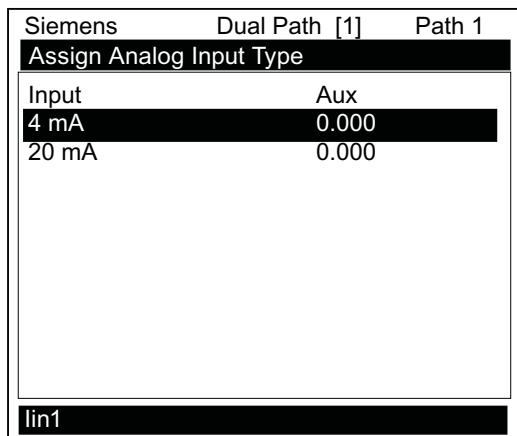



3. To enable numeric entry, press the <Right Arrow>. Type a numeric value corresponding to a 4mA input signal.
4. To store the data press <ENTER>. This moves the cursor to [20 mA].
5. To enable numeric entry, press the <Right Arrow>. Type the numeric value corresponding to a 20mA input signal.
6. To store the data, press <ENTER>.

### [PckW] Menu Cell

The [PckW] menu cell represents power consumption in kilowatts. When assigned to an analog input this parameter will be used to compute chiller or heating efficiency.

### CE Method

The ultrasonic energy flow meters can be configured to provide an Energy Efficiency output. Modifications were implemented using the standard analog input spanning methods in an effort to simplify operator monitoring of air conditioning efficiency data. These changes allow the flow meter to calculate chiller efficiency. The flow meter calculates chiller or heating efficiency through use of an available analog input, which can be assigned to represent power consumption (kW).

---

#### Note

Refer to [www.EngineeringToolBox.com](http://www.EngineeringToolBox.com) ([www.EngineeringToolBox.com](http://www.EngineeringToolBox.com)).

---

### KW/ton

Cooling Load in kW/ton - Commonly used for large commercial and industrial air-conditioning, heat pump and refrigeration systems. KW/ton is defined as the ratio of the rate of energy consumption in kW to the rate of heat removal in tons at the rated condition. The lower the kW/ton the more efficient the system.

$$\text{kW/ton} = P_c / E_r$$

where:  $P_c$  = energy consumption (kW)

$E_r$  = heat removed (ton)

### COP

Coefficient of Performance - COP is the basic unit less the parameter used to report the efficiency of refrigerant based systems. COP is the ratio between useful energy acquired and energy applied.

$$\text{COP} = E_u / E_a$$

Where:  $E_u$  = useful energy acquired

$E_a$  = energy applied.

**COP** can be used to define both cooling efficiency or heating efficiency as with a heat pump.

- For cooling, COP is defined as the ratio of rate of heat removal to the rate of energy input to the compressor.
- For heating, COP is defined as the ratio of the rate of heat delivered to the rate of energy input to the compressor.

**COP** can be used to define the efficiency at a single standard or non-standard condition or a weighted average seasonal condition. The term may or may not include the energy consumption or auxiliary systems such as indoor or outdoor fans, chilled water pumps, or cooling tower systems. For purposed of comparison the higher the COP the more efficient the system.

**COP** can be treated as an efficiency where COP of 2.00 = 200% efficient. For unitary heat pumps, ratings at two standard outdoor temperatures of 47°F and 17°F (8.3°C and -8.3°C) are typically used.

## EER

Energy Efficiency Ratio - EER is used to define the cooling efficiency of unitary air conditioning and heat pump systems.

The efficiency is determined at a single rated condition specified by the appropriate equipment standard and is defined as the ratio of net cooling capacity (or heat removed in Btu/h) - to the total input rate of electric energy applied (in watt hours). The units of EER are Btu/w.h.

$$EER = E_c / P_a$$

Where: EER = energy efficient ratio (Btu/w.h)

$E_c$  = net cooling capacity (Btu/h)

$P_a$  = applied energy (w.h)

## 7.9 Energy AnCal

The [Energy AnCal] menu cell allows you to enter an artificial energy rate in current rate units that will drive the flow meter analog outputs, energy totalizer output and the display screen shown below. You can use AnCal to check the analog outputs or as a reference source for calibrating external devices such as remote display screens or chart recorders and RTUs. To test the Totalizer function, leave Energy AnCal active long enough for an accumulation to appear on the diagnostic data screen shown below. Moving the cursor from the menu cell cancels the AnCal function.

Siemens	2 Channel [1]	ABC
<b>Energy Rate Simulation Control</b>		
Energy Rate MBTU/H	10.0434	①
Energy Total KBTU	1211.8603	
Ts	75.07 F	
Tr	31.73 F	
Td	43.33 F	
CE kW/ton	1.100	
Energy ANCAL	=10.000	
<b>Energy Data</b>		

- ① The [Energy Rate] menu cell immediately reflects the Energy AnCal entry. Over time the Energy Total will also increase.

### To activate Energy AnCal:

1. Move the cursor to the [Energy AnCal] menu cell by pressing <Up/Down Arrow>.
2. Press <Right Arrow> to enable numeric entry. Note that an equal sign (=) appears before number.
3. Type the desired flow rate using current rate units (e.g., 10.00 MBTU/H). Note that the [Flow] menu cell now reflects the artificial rate.
4. Move the cursor away from the menu cell by pressing <Up/Down Arrow> to turn Energy AnCal off.

## 7.10 Analog Output Trim

### Introduction

Analog Out Trim function allows you to fine-tune the flow meter's analog voltage and current outputs using a multi-meter connected to the output under test. In addition, you can use a frequency counter to fine-tune the flow meter's pulse rate output.

### Note

The current, voltage, and Pgen trimming will be limited by the 12-bit resolution of the flow meter's D/A Convertor (DAC).

7.10 Analog Output Trim

1. From the [Meter Facilities] menu, scroll to the [Analog OutTrim] menu.
2. Press the <Right Arrow> to access the option list.

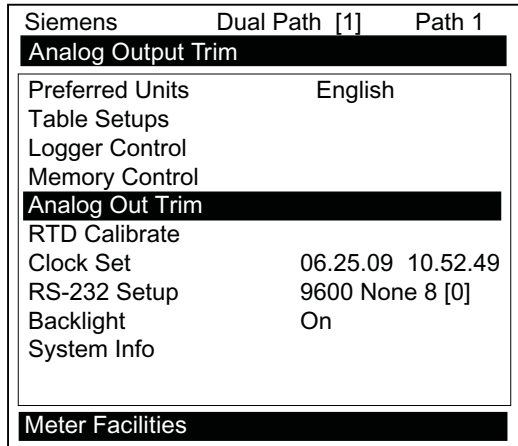

Table 7- 8 Analog Out Trim Menu Structure

Analog Out Trim	Trim Io1/Io2	Operate Trim@4mA Indicated mA=x.xx
	Trim Vo1/Vo2	Operate Trim@2V Indicated V=x.xx
	Trim Pgen1 / Pgen2	Operate Trim@1 Hz Indicated Hz=xxxx

**Current Output Trim (Io1 & Io2)**

**Note**

Can be trimmed to within .005mA of nominal.

**To calculate a current output:**

1. Set up an ammeter to read amps, then connect it to the supply and return terminals of the current output under test.
2. Move the highlight to the port to be tested, press <Right Arrow> and then press <Down Arrow> to move the cursor to [Trim @ 4mA].

Siemens	Dual Path [1]	Path 1
Trim 4-20 mA output		
Trim Io1	>Operate	
Trim Io2	Trim @ 4mA	
Trim Vo1	Operate	
Trim Vo2	Operate	
Trim Pgen1	Operate	
Trim Pgen2	Operate	
Analog Out Trim		

3. Press <ENTER>. This triggers a 4.00 mA pop-up window. The ammeter will now be reading 4.00 mA.
4. If the ammeter reading does not match, use the numeric keys to type in the ammeter reading.
5. Press <ENTER> to register setting. This adjusts the flow meter's DAC (digital-to-analog converter) so that a 4mA output corresponds with 4mA on the ammeter.
6. Re-check the ammeter to make sure that it is now reading 4mA.

### Voltage Output Trim (Vo1 & Vo2)

**Note**

Can be trimmed to within .0025 V of nominal.

**To calculate a voltage output:**

1. Set up the multi-meter to read volts, then connect it to the supply and return terminals of the voltage output under test.
2. Move the highlight to the port to be tested by pressing <Up/Down Arrow>, press <Right Arrow>, then press <Down Arrow> to move the cursor to [Trim @ 2V].

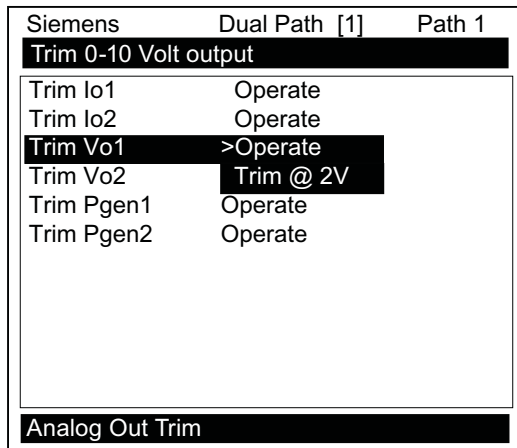

3. Press <ENTER>. This triggers a 2.00 Volts pop-up window. The multi-meter will now be reading 2.00 Volts.
4. If the multi-meter reading does not match, use the numeric keys to type in the multi-meter reading.
5. Press <ENTER> to register setting. This adjusts the flow meter's DAC (digital-to-analog converter) so that a 2.00 Volts output corresponds with 2.00 Volts on the multi-meter.
6. Re-check the multi-meter to make sure that it is now reading 2.00 Volts.

## Pgen Output Trim

---

### Note

Can be trimmed to within 1.25 Hz of nominal.

---

### To calibrate a pulse rate output

1. Connect a frequency counter to the signal and reference terminals of the pulse rate output under test.
2. Move the highlight to the port to be tested by pressing <Up/Down Arrow>, press <Right Arrow>, then press the <Down Arrow> to move the cursor to Trim @ 1kHz.
3. Press <ENTER>. This triggers a 1 kHz pop-up window. The frequency counter will now be reading 1 kHz.
4. If the frequency counter reading does not match, use the numeric keys to type in the frequency counter reading.
5. Press <ENTER> to register setting. This adjusts the flow meter's DAC (digital-to-analog converter) so that a 1 kHz output corresponds with 1 kHz on the frequency counter.
6. Recheck the frequency counter to make sure that it is now reading 1 kHz.

## 7.11 RTD Calibration

### Resistive Temperature Device (RTD) Calibration

The RTD Calibrate Menu appears on all SITRANS F 1010 models. Use this menu to calibrate Temperature Sensors to an external standard. It is important to note that Siemens RTD temperature sensors are factory-calibrated for high accuracy. We recommend that before deciding to perform the calibration, check the current RTD reading in the [Diagnostics/Liquid Data] menu. You may find that you do not even need to calibrate the sensor. In any case, make sure that the temperature reading stabilizes before proceeding further. The [RTD Calibrate] menu allows you to perform an external calibration, which can be accomplished either by data entry of the current RTD temperature or by a 0°C (32°F) Ice-Bath procedure. You can switch between the intrinsic and external calibration modes at any time.

---

### Note

If you perform an external temperature calibration, you should mark and record the location of each connector and sensor-cable. Once you have re-calibrated the temperature sensors, changing the sensor/connector orientation established during the procedure may void the calibration.

---

7.11 RTD Calibration

1. From the [Meter Facilities] menu scroll to the [RTD Calibrate] menu.
2. To access the [RTD Calibrate] menu press <Right Arrow>.

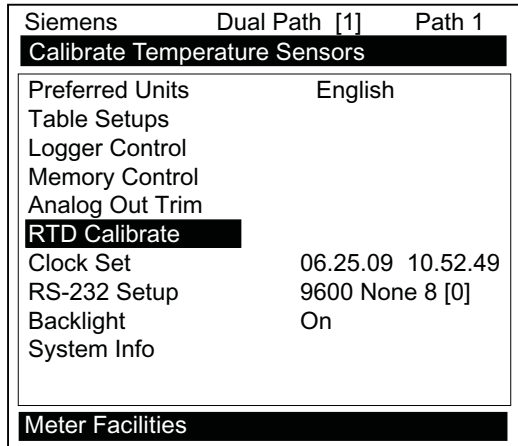

Table 7- 9 RTD Calibrate Menu Structure

RTD Calibrate	Ch 1 Ts - RTD 1→	Factory / User Cal
	Ch 1 Tr - RTD -2	Factory / User Cal
	Ch 2 Ts - RTD 3→	Factory / User Cal
	Ch 2 Tr - RTD 4→	Factory / User Cal

**RTD Calibration by Entry Data**

The [RTD Calibrate] menu allows you to adjust the intrinsic RTD reading to match an external reference thermometer by directly entering its reading. Only perform this procedure while the RTD under test is installed and currently measuring temperature.

**To enter the current RTD temperature:**

1. From the [RTD Calibrate] menu press <Right Arrow> to access the RTD option list.
2. Press <Right Arrow> to highlight the RTD you want to calibrate (RTD 1 or RTD 2).
3. Move the highlight to [Factory] or [User Cal] then press <ENTER>.



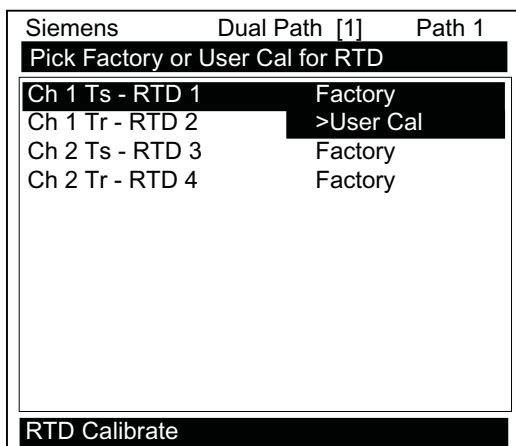

4. This triggers the pop-up window:

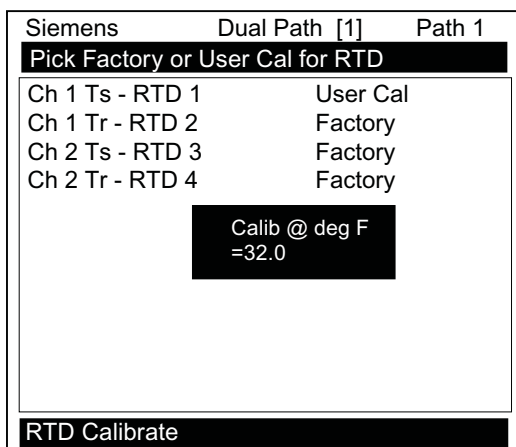

5. To enable numeric entry <Right Arrow>, then type in the reading of the reference thermometer (e.g., 72.0).
6. To recalibrate the RTD sensor <ENTER>. To verify the calibrated reading, go to the Dual Path Flow menu [Diagnostic Data/Liquid Data] menu to check the current RTD output. Make sure that it coincides with the reading of the reference thermometer. Repeat for the other RTD, if necessary.

**Note**

Factory Calibration provides an additional prompt after a new temperature is entered: [Are you Sure? No Yes]. It is recommended that you use [User Cal] to avoid alteration of preset factory calibration.

### Ice Bath RTD Calibration

Use distilled, deionized water and ice mixture at 0°C (32°F) equilibrium for an ice bath. Ensure temperature with a reference thermometer. Siemens can not assume responsibility for the incorrect design, construction or operation of an Ice Bath.

<b>NOTICE</b>
<b>Sensor Damage</b>
If RTD sensor makes direct contact with ice during an ice bath calibration procedure the sensor may be damaged and the calibration results will be incorrect.
Do not allow an RTD sensor to make direct contact with ice during an ice bath calibration procedure.

#### To perform a 0°C (32°F) calibration:

1. Immerse RTD sensor in deionized water and ice mixture. Stir the mixture constantly.
2. In the [RTD Calibrate] menu move the highlight by pressing the <Up/down Arrow> to the RTD you want to calibrate (RTD 1 or RTD 2).
3. To access the RTD option list press <Right Arrow>. Move the highlight to [User Cal] then press <ENTER>. This triggers the pop-up window.
4. When you are sure that the RTD Sensor is at 0°C (32°F), press <ENTER> to recalibrate the RTD sensor.
5. To verify the calibrated reading, go to Dual Path Flow [Diagnostic Data/Liquid Data] menu to check the current RTD output. Make sure that it coincides with the reading of the reference thermometer. Repeat for the other RTD, if necessary.

## 7.12 Reflexor

Reflexor is one of the operating modes available on certain SITRANS F 1010 models. The Reflexor operating mode utilizes Doppler flow detection along with digital signal processing techniques to successfully measure flow under conditions that may not be suitable for transit-time flow measurement. The Reflexor samples the flow stream as it detects Doppler shift. It converts the Doppler shift information by use of Fast Fourier Transform (FFT) and filters the FFT to determine the flow rate. The Reflexor mode will operate with many of the same sensors that are used with transit-time flow measurement along with those which are specifically designed for Doppler flow measurement. Use of any other sensor than shown in these instructions may result in failure to measure or give an incorrect flow rate indication.

### Typical Installation

The typical steps to complete the Reflexor installation procedure are as follows:

1. Collect the site data (pipe and liquid data, part numbers, etc.).
2. Choose a mounting location for the flow sensors.

3. Prepare the pipe for sensor's mounting.
4. Access the Installation Menu and create a site.
5. Enter the pipe parameters.
6. Mount flow sensors on pipe and connect to flow meter.
7. Invoke the sensor installation procedure.
8. Optimize installation through use of the Spectra Display and diagnostic data.

Almost all menu cells will contain default parameters and will not require any additional action. To obtain operation you will only need to access the menu cells for required parameters, such as pipe data. Obtaining accurate flow rate data will take less than five minutes.

Application conditions may require you to mount the sensors using the adjacent mounting method as described and shown in this section.

### **Selecting a Sensor Set**

Maximum sensitivity will be obtained with use of the 191N1S sensor set.

Alternative sensors recommended for use by Reflexor include:

- 1011 Universal size C1, C2 and C3
- 1011 HP-T1 size B1H and A3H
- 1011 HP-T2 size B1H and A3H
- 1011 HP-T3 size B1H and A3H
- 991 Universal size 2 and 3A High and Very High Temperature versions
- 990 (991 Sensor)

The sensor models are also available for submersible and extended temperature applications.

### Selecting Sensor Mounting Location

Select a sensor mounting location that has a fully developed flow profile. Do not locate the sensor so that sonic energy enters a region that is not representative of the flow velocities at the measuring location. Use the figure below as a guide to select the proper mounting location.

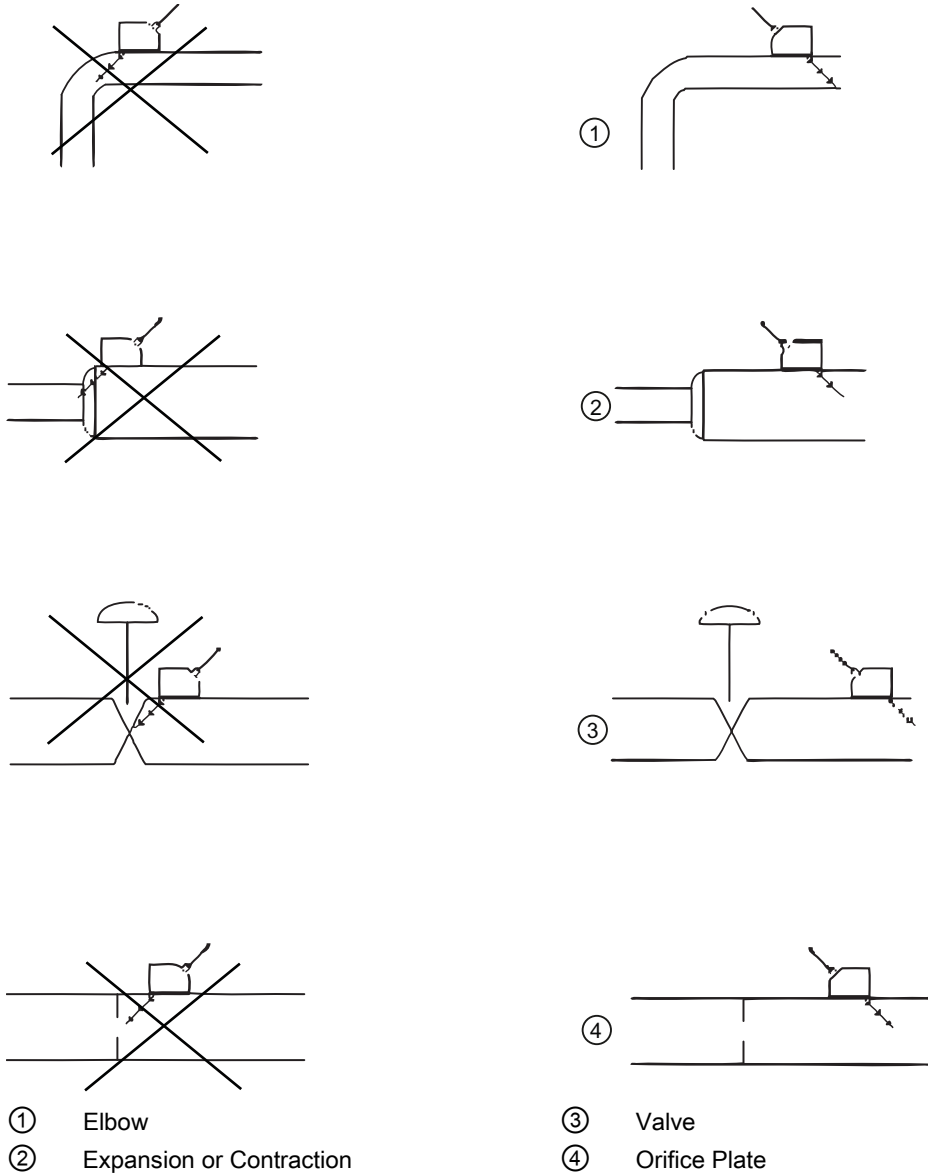

Figure 7-1 Sensor Mounting Examples

## Mounting Sensors

Two mounting configurations are available in the Reflexor Mode:

- Adjacent mounting locates the two sensors alongside each other using a single mounting chain or strap.
- In-Line mounting locates the two sensors axially along the pipe using two mounting chains or straps.

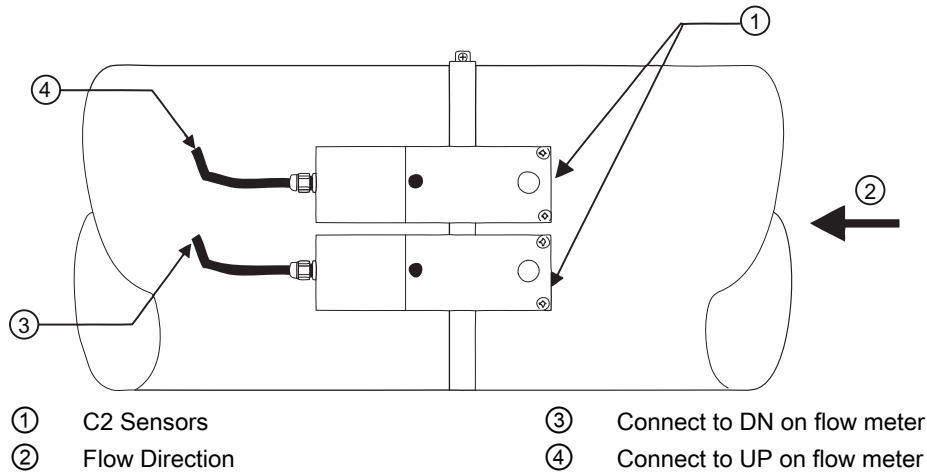

Figure 7-2 Adjacent Sensor Mounting

On inline mounted metal pipes the Receive Sensor is always located downstream of the Transmit Sensor. On plastic pipes the Transmit Sensor is always located downstream of the Receive Sensor.

Table 7- 10 Inline Metal and Plastic Pipe Cable Connections

Sensor	Metal Pipe	Plastic Pipe
C2 Sensor (A)	DN	UP
C2 Sensor (B)	UP	DN

In both cases, the cable entry will be on downstream side. Adjacent mounting will provide the maximum sensitivity to flow. Refer to the appropriate sensor installation drawing for the 191N1S (Installation Drawing 191N1S-7).

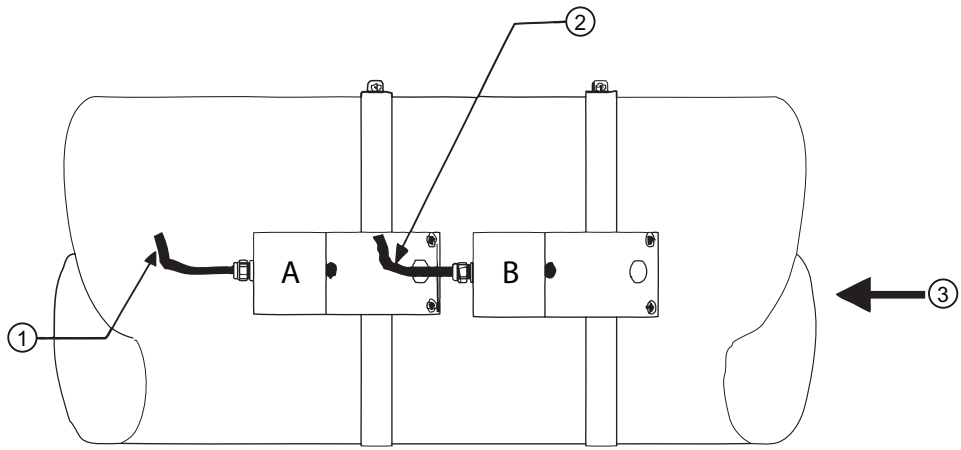

- ① Connect to DN on flow meter for metal pipe (Receive) / Connect to UP on flow meter for plastic pipe (Transmit)
- ② Connect to UP on flow meter for metal pipe (Receive) / Connect to DN on flow meter for plastic pipe (Transmit)
- ③ Flow Direction

Figure 7-3 In-Line Sensor Mounting

### Connecting Sensor Cables

Connect sensor cables between the sensors and the flow meter. The XMIT (transmit) sensor is connected to the Up cable connection and RCV (receive) sensor is connected to the Down cable connection. The UP/DN orientation is important for the in-line sensor configuration. It is not a factor for the adjacent configuration.

### Select Reflexor Operating Mode

Select [Meter Type] as [Reflexor] for the channel that is to be used as Reflexor. Dual channel units may have either one or both channels used in the Reflexor mode.

## Installing Reflexor Operating Mode

1. From the [Meter Type] menu press the <Right Arrow>, select the desired channel setup and press <ENTER>.
2. Press the <Right Arrow>, scroll to [Reflexor] and press <ENTER>.

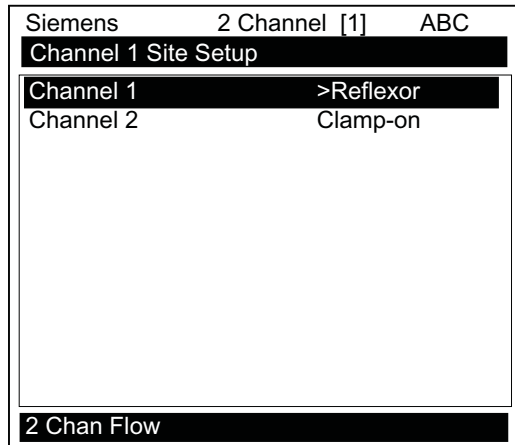

3. At the [Channel Setup] menu press the <Right Arrow>.
4. Scroll down to [Create/Name Site] and create a site or use a previous Saved Site setup by highlighting [Recall Site].

---

### Note

If a previous Saved Site is recalled, and the same sensor and location is used, then no other installation steps are required.

---

5. Press the <Left Arrow> and scroll to [Pipe Data] and enter the required pipe data.

## Sensor Selection

1. From [Pipe Data] scroll to the [Install Sensor] menu and press the <Right Arrow>.
2. At [Sensor Model], press the <Right Arrow> and select the proper group of sensors that match the mounted sensor set. For all 191N, select 190.
3. At [Sensors Size], select the proper size of sensor mounted. For all 191N, select 191.

---

### Note

If the Flow Volume and Time units are not set to the default units of Gallons per Minute, then it is recommended to change those units now by use of the [Flow/Total Units] menu.

---

4. In the [Install Sensor] menu, scroll down to [Flow Range], press the <Right Arrow> and select the lowest flow range rate available that is at least **two times higher** than the maximum flow expected at this application.
5. At [Install Complete], for new installations, press the <Right Arrow>, select [Install], and then select [Yes]. Press <ENTER>.

Siemens	2 Channel [1]	ABC
<b>Install Completed?</b>		
Sensor Model	1011 Universal	
Sensor Size	C2	
Flow Range GAL/MIN	14.99	
<b>Install Complete</b>	<b>Yes</b>	
Spectra Graph	No	
<b>Install Sensor</b>		

The flow meter is now operational and the display will show flow by pressing the <MENU> key.

### The Spectra Graph

The Spectra Graph provides a powerful tool to determine if the installation has achieved an adequate margin of operation. It also eliminates the possible effects of mechanical vibration and external RFI (Radio Frequency Interference). Mechanical vibration and external RFI can cause other types of Doppler flow meters to be inaccurate. The Spectra Graph display provides keypad control keys that allow adjustments of application dependent parameters, if required, while observing the results of these adjustments. Application dependent parameters are the Low and High Limit Cursors and the Noise Cursor. In most cases, only the Noise Cursor will be required to be adjusted.



### Selecting the Spectra Graph Display

1. In the [Install Sensor] menu scroll to [Spectra Graph] and press the <Right Arrow>.
2. Press the <Down Arrow> to select [Yes] and press <ENTER>.

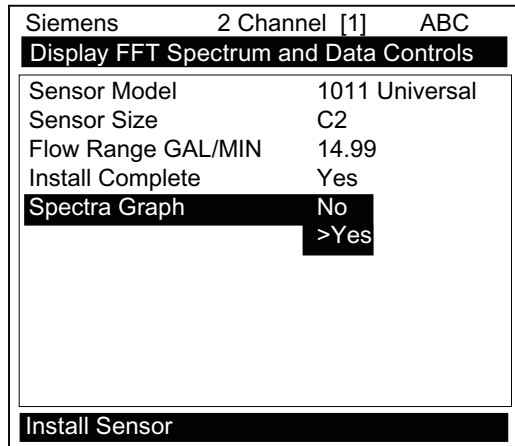

The Spectra Graph display shows the results of the Fast Fourier Transform (FFT) performed by the flow meter.

- The horizontal scale represents flow velocity with the higher velocities on the right and lower velocities on the left.
- The vertical axis is relative amplitude or magnitude; each bar shows the relative amplitude for a velocity range.

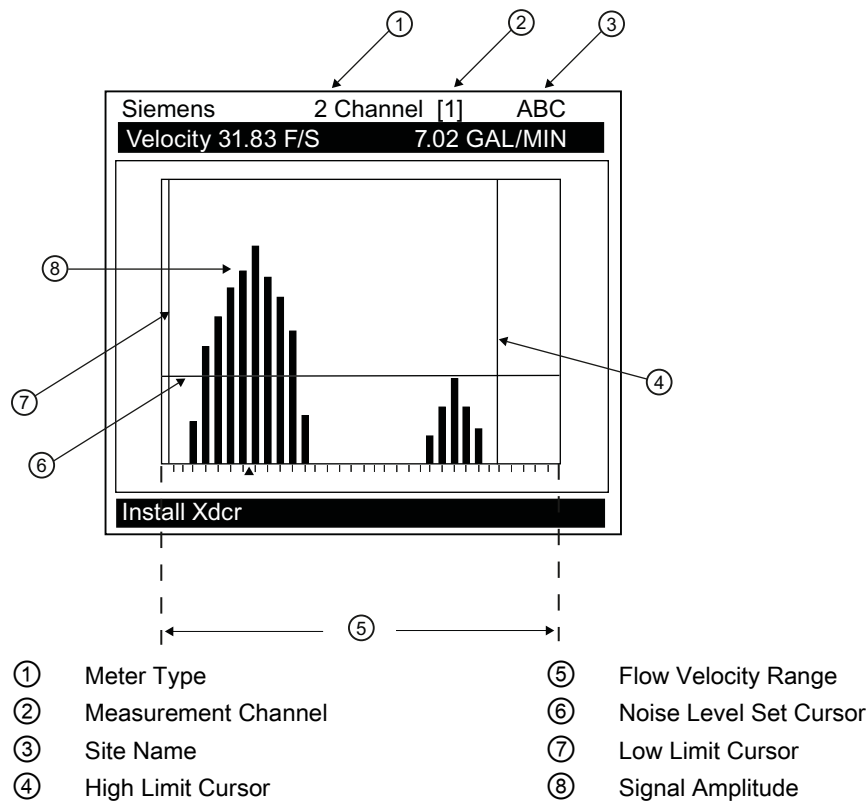

Figure 7-4 Spectra Graph Display Screen

The reported flow rate is the mean value of the included Spectra Graph bars. It is computed by excluding signals that are lower (to the left of) than the Low Limit Cursor or higher (to the right of) than the High Flow Cursor or lower (under) than the Noise Cursor.

### Spectra Graph Cursor Use

Table 7- 11 Cursor Definitions

Cursor	Definitions
High Limit Cursor	This cursor appears as a vertical line on the right side of the Spectra Graph. All signals to the right of this line will be excluded from the flow calculation. Use this adjustment if the right side of the Spectra Graph has noise that is larger in amplitude than the signal that is produced by flow. The cursor may be arbitrarily placed at two times the maximum flow expected.
Low Limit Cursor	This cursor appears as a vertical line on the left side of the Spectra Graph. All signals to the left of this line will be excluded from the flow calculation. Use this adjustment if the left side of the Spectra Graph has noise that is larger in amplitude than the signal that is produced by flow. The cursor may be arbitrarily placed at one half the minimum flow expected.
Noise Level Set Cursor	This cursor appears as a horizontal line on the Spectra Graph. All signals below this line will be excluded from the flow calculation. Position the cursor approximately one quarter the height of the FFT peak.

### Using Spectra Graph Data and Controls

When the Spectra Graph is first displayed:

- The data shown on the top highlighted line shows Velocity in feet-per-second (F/S) on the left side.
- The volumetric Flow Rate in the current rate units is displayed on the right side.

You can scroll the data shown by pressing the <Up and Down> Arrows.

1. Pressing the <Up Arrow> changes the data in the highlight to [Diagnostic Data] containing, from left to right: (Hz) Doppler shift frequency in Hertz, (mV) Signal Amplitude in millivolts, (FFT Pk) Peak FFT magnitude and (%D) FFT Percent Deviation. Carefully inspect the data for Signal Amplitude and Percent Deviation. Refer to the "Available Adjustments to Spectra Graph" table and the "Reflexor Diagnostic Data" table in this section for details. Press the <Down Arrow> to return to [Velocity].
2. Press the <Down Arrow> from Flow Velocity in feet per second (F/S) to advance to the Noise Level Set cursor control. A numeric indication of the Noise Level Cursor position is provided in the highlighted area. Refer to the "Available Adjustments To Spectra Graph" table for details.

3. Adjust the Noise Level cursor, if required, by pressing the <+> key to increase or <-> key to decrease.

---

**Note**

A delay in response to all keys will occur. This is due to the longer periodic sampling of the keyboard by the processor while performing FFT's.

---

4. Press the <Down Arrow> from Noise Level to advance to the High Limit cursor control. The <+> and <-> key are active in this position. Refer to the "Available Adjustments To Spectra Graph" table for details.
5. Press the <Down Arrow> from High Limit to advance to the Low Limit cursor control. The <+> and <-> keys are active in this position. Refer to the "Available Adjustments To Spectra Graph" table for details.
6. Press the <Down Arrow> from Low Limit to advance to the Carrier FX control. The <+> and <-> keys are active in this position.
7. Press the <Down Arrow> from Carrier FX to advance to the Diagnostic Data Display. The <+> and <-> keys are active in this position.
8. To exit the Spectra Graph, press the <MENU> key.
9. To display the Digital Flow Display, press the <MENU> key from any Installation Menu location.

### Available Spectra Graph Adjustments

Adjustment	Function	Notes
Noise Level Set	Noise Filter	Set to approximately one quarter the Peak FFT value for typical flow conditions.
High Limit	Low Pass Filter Setting	Set to two times the maximum flow rate.
Low Limit	High Pass Filter	Set to one half minimum flow if noise is present. In most cases, leave at zero.
Carrier Fx	Transmit Frequency Code	Adjust only under guidance of technical support staff.

### Reflexor Diagnostic Data

The [Diagnostic Data] menu and the [Application Info] sub menu screen provide one location where all diagnostic data can be viewed.

---

**Note**

Adjustments can not be made on the [Application Info] menu screen. Adjustments can only be made on the Spectra Graph.

---

Table 7- 12 Diagnostic Data

Application Information	Function / Explanation
Low Limit	High Pass Filter Setting
High Limit	Low Pass Filter Setting
Noise Level Set	Noise Filter Setting
Doppler Frequency (Hz)	Average FFT Frequency
% Deviation	The width of Spectra is used to determine beam penetration and calibration. The selection of "Slurry" in Application Data is recommended for flow rate indication accuracy when the % Deviation is less than 25. For % Deviation above 35 the use of "Liquid" is recommended.  For applications that continuously have % Deviation between 25 and 35 proper selection of either Liquid or Slurry can be confirmed by comparison to a known flow reference.
Signal Peak-to-Peak mV	Peak-to-Peak demodulation signal amplitude. The acceptable range is between 100 and 3200 mV during typical flow conditions. If less than 100 mV, check Sensor type used and mounting configuration. If greater than 3200 mV, try in-line mounting and/or "detune" Carrier Fx.
FFT s/sec	Number of FFTs per second
FFT Peak	Peak FFT Amplitude
Carrier Fx	Transmit Frequency code

Siemens	2 Channel [1]	ABC
<b>Sets low flow limit filter</b>		
Low Limit GAL/MIN	>0.00	
High Limit GAL/MIN	16.75	
Noise Level Set	2	
Doppler Freq	8571	
% Deviation	100.00	
Signal PK-PK mV	27	
FFT s/Sec	28	
FFT Peak	0	
Carrier Fx	27	
<b>Application Info</b>		

### Display of "F" at No-Flow conditions

It is normal for the digital display to show an "F" for the no flow condition since the lack of Spectra information during no flow is the same as a fault condition.

---

#### Note

Selecting the [Operation Adjust] menu cell [Zero/Fault Set] allows the option of indicating Zero Flow rather than a Fault.

---

### Selecting Liquid Composition

The width of the Spectra wave shape is an indication of the depth of penetration of sonic energy into the flow stream. The % Deviation is a measure of the width of the Spectra and is representative of the penetration of the sonic beam into the liquid.

Select [Slurry] in the [Application Data] menu for better flow rate indication accuracy when the % Deviation is less than 25 with typical flow conditions.

For % Deviations above 35, select [Liquid]. For applications that continuously have % Deviations between 25 and 35, proper selection of either [Liquid] or [Slurry] can be confirmed by comparison to a known flow reference.

Siemens	2 Channel [1]	ABC
Pick Liquid or Slurry Flow Calibration		
Liq Composition	Liquid	
Density S.G.	1.00	
Application Data		

### Other Menu Entries

All other flow meter menu entries will operate and be used in the same manner as the transit time flow measurement mode.



## Alarm, error, and system messages

### Alarm Codes

The following alarm codes appear on the main display of the flow meter.

Table 8- 1 Alarm Codes and descriptions

Letter Codes	Alarm Code	Description
SPACE	Spacing	Transducer spacing may need adjustment
EMPTY	Empty	Pipe is empty
HI/LO	Rate	Flow above High setting or below Low setting
FAULT	Fault	Three continuous seconds without new data update
AER	Aeration	Current aeration percentage exceeds the alarm set point
MEMRY	Memory	Last valid reading for a selected interval during Fault condition
MAKUP	Makeup	In-Process Makeup occurred
The following alarm codes appear in the Datalogger status messages:		
I	Interface	Liquid Vs exceeds interface alarm set point
P	Pig	Pig passage detected (optional)
Z	Zeromatic	ZeroMatic signal fault

The displays shown below indicate where the Alarm Codes appear on the screen. Press <UP> or <DOWN> arrows to change screen views.

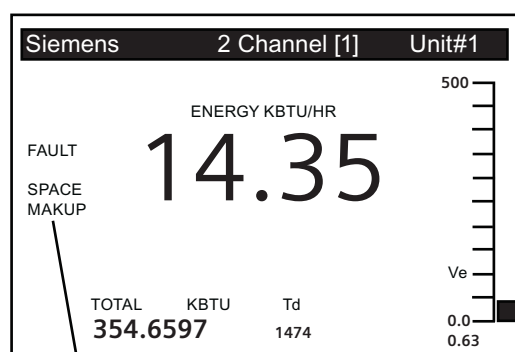

① Alarm Codes

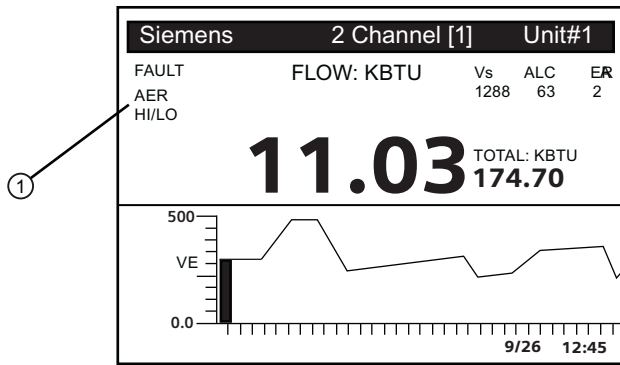

① Alarm Codes



## Service and maintenance

### 9.1 Maintenance

The device is maintenance-free, however, a periodic inspection according pertinent directives and regulations must be carried out.

An inspection can include check of:

- Ambient conditions
- Seal integrity of the process connections, cable entries, and cover screws
- Reliability of power supply, lightning protection, and grounds

### 9.2 Technical support

<b>NOTICE</b>
<b>Repair and Service</b>
Repair and service must be carried out by approved Siemens personnel only.

---

**Note**

Siemens defines sensors as non-repairable products.

---

#### Technical Support

If you have any technical questions about the device described in these Operating Instructions and do not find the right answers, you can contact Technical Support:

- Via the Internet using the **Support Request:**  
Service and support (<http://www.siemens.com/automation/service&support>)
- Phone: +49 (0) 911 895 7222 / 1 800 333-7421

Further information (Page 10) about our technical support is available in the Internet at Technical support (<http://support.automation.siemens.com/WW/view/en/16604318>)

#### Service & Support on the Internet

In addition to our documentation, we offer a comprehensive knowledge base online on the Internet at:

Support request (<http://www.siemens.com/automation/support-request>)

There you will find:

- The latest product information, FAQs, downloads, tips and tricks.
- Our newsletter, providing you with the latest information about your products.
- A Knowledge Manager to find the right documents for you.
- Our bulletin board, where users and specialists share their knowledge worldwide.
- You can find your local contact partner for Industry Automation and Drives Technologies in our partner database.
- Information about field service, repairs, spare parts and lots more under "Services."

### **Additional Support**

Please contact your local Siemens representative and offices if you have additional questions about the device

Find your contact partner at:

Local contact person (<http://www.automation.siemens.com/partner>)

## **9.3 Return procedures**

Enclose the delivery note, the cover note for return delivery together with the declaration of decontamination form on the outside of the package in a well-fastened clear document pouch.

## Required forms

- **Delivery Note**
- **Cover Note for Return Delivery** with the following information  
Return delivery form (<http://support.automation.siemens.com/WW/view/en/16604370>)
  - product (ordering number)
  - number of devices or spare parts returned
  - reason for the return
- **Declaration of Decontamination**  
Decontamination declaration  
([http://pia.khe.siemens.com/efiles/feldg/files/Service/declaration\\_of\\_decontamination\\_en.pdf](http://pia.khe.siemens.com/efiles/feldg/files/Service/declaration_of_decontamination_en.pdf))  
With this declaration you certify *that the returned products/spare parts have been carefully cleaned and are free from any residues.*  
If the device has been operated together with toxic, caustic, flammable or water-damaging products, clean the device before return by rinsing or neutralizing. Ensure that all cavities are free from dangerous substances. Then, double-check the device to ensure the cleaning is completed.  
We shall not service a device or spare part unless the declaration of decontamination confirms proper decontamination of the device or spare part. Shipments without a declaration of decontamination shall be cleaned professionally at your expense before further proceeding.  
You can find the forms on the Internet and on the CD delivered with the device.

## 9.4

### Battery disposal



In accordance with EU directive 2006/66/EC, batteries are not to be disposed of using municipal waste disposal services.

Waste industrial batteries are accepted back by Siemens or by the local Siemens representative. Please talk to your local Siemens contact (<http://www.siemens.com/automation/service&support>) or follow the return procedures (Page 140) of Siemens.



## Troubleshooting

### 10.1 Troubleshooting

The following is list of troubleshooting tips and messages that you may encounter. They include explanations and, in some cases, a recommended action. If a problem seems unsolvable, contact your local Siemens office or regional Ultrasonic Flow Representative for expert help at: <http://www.automation.siemens.com/partner> (<http://www.automation.siemens.com/partner>).

Table 10- 1 Troubleshooting Tips

Error or Message	Probable Cause	Solution
Memory Full!	Response to an attempt to save site data, when data memory is full.	Delete an obsolete site or clear Datalogger memory to make room for the new data.
Memory Corrupted!	Memory read error occurred while accessing the active site data.	Refer to F4 reset procedure in the Operation Instructions manual.
Chan Not Setup	Response to an attempt to invoke an operation that requires a channel to be enabled.	Enable the channel [Channel Setup - Channel Enable - Yes]. Note that a channel cannot be enabled until an "Install" operation is completed.
Clr Active Memory?	Response to pressing and holding the F4 key during power-up	Use the F4 function to restore operation if a severe event (e.g., a violent power surge) disrupts system operation.
Clr Saved Data?	[Clr Saved Data?] only appears after pressing the <Down Arrow> in response to [Clr Active Memory?].	Answering Yes to [Clr Saved Data?] will erase <b>ALL</b> saved data. To invoke in RS-232 serial mode, type @@@ and then press <Enter> key.
<EOT>	Response to a request to output Datalogger data to the printer or the Graphics screen when no Datalogger data exists or at the end of a transmitted file.	Set up the Datalogger.
No Sites - Press <ENTER>	Response while trying to recall/delete a site setup when no sites are stored.	Create a site.
Security	Response upon changing previously entered data when security switch is in [Disable] position or security code has been entered.	<ul style="list-style-type: none"> <li>• Change switch position to [Enable].</li> <li>• Enter previously set security code.</li> </ul>
RTC Error	Component level problem.	<ul style="list-style-type: none"> <li>• Meter requires service. Request RMA.</li> </ul>

Error or Message	Probable Cause	Solution
- - -F- - - Fault Alarm	<ul style="list-style-type: none"> <li>• Loss of signal strength (ALC)</li> <li>• Change of Rx signal location (Beam Blowing)</li> </ul>	<ul style="list-style-type: none"> <li>• Recouple sensors with fresh couplant.</li> <li>• Install sensors in Direct mount mode.</li> <li>• Note: If problem persists call Tech support.</li> </ul>
Re-space Index	The measured liquid sonic velocity (Vs) is more than +/- 25% of the average Vs range.	<ul style="list-style-type: none"> <li>• Assure proper pipe dimensions and/or Liquid data entries are correct.</li> <li>• Properly enter correct Sensor Size into the meter [Install Sensor] menu.</li> <li>• Confirm sensor spacing is correct by checking [Install Sensor] menu spacing parameters.</li> </ul>
Invalid Setup (use Direct Mode)	During the Initial Makeup the system detects invalid sensor spacing, erroneous liquid pipe parameters, or some other factor that prevents it from completing the Initial Makeup.	<p>This may be due to one of the following:</p> <ul style="list-style-type: none"> <li>• An out-of-range data entry.</li> <li>• An invalid condition (e.g., overlapping sensors in Reflect Mode). If selecting Direct Mode does not resolve, review all site setup and sensor installation choices particularly data entered for pipe and liquid.</li> <li>• In Reflect Mode the flow meter detects that the pipe wall signal may infringe upon the liquid signal. Use Direct Mode instead.</li> <li>• Press &lt;ENTER&gt;, &lt;Up Arrow&gt;, &lt;Down Arrow&gt;, or &lt;Left Arrow&gt; to abort install routine. Continue programming other site data in anticipation of resolving the difficulty later. Call technical support for help if necessary.</li> </ul>

Error or Message	Probable Cause	Solution
Low Signal - Press <ENTER>	During the Initial Makeup the flow meter decides that the level of the receive signal is insufficient for proper operation.	<p>Some reasons for low signal are:</p> <ul style="list-style-type: none"> <li>• Invoking [Install Complete] on an empty pipe.</li> <li>• Coupling compound insufficient not applied or evaporated.</li> <li>• A disconnected or broken sensor cable.</li> <li>• The pipe needs to be conditioned at the mounting location.</li> <li>• Flush out large air bubbles.</li> <li>• The sensor cables are defective or not connected to the correct channel.</li> <li>• The Set Empty routine performed when pipe was NOT actually empty.</li> </ul> <p>If you locate and correct the improper condition immediately, press &lt;ENTER&gt; to resume the installation procedure. Otherwise, press the &lt;Left Arrow&gt; to abort the installation and conduct a thorough investigation.</p>
Detection Mode	If it appears that the flow meter cannot complete an Initial Makeup it means that the pipe and/or liquid conditions do not permit a receive signal that meets the flow detection standards. The system will not operate.	<p>Attempt to improve operating conditions by reinstalling the sensors at a different spacing offset, or even at a different location on the pipe.</p> <p>Switching from Reflect to Direct Mount may solve the problem. However, operation may not be possible if there is poor liquid or pipe wall sonic conductivity.</p>

**Note**

If you receive a Detection Fault message, it is strongly recommended that the Technical Service Department (<http://www.automation.siemens.com/partner>) be contacted.

## 10.2 F4 Reset Procedure

You may encounter an operating problem that blocks access to the Diagnostics Menu, or the flow meter may operate erratically after exposure to a power transient or some other traumatic event. These cases may require use of the F4-reset sequence to restore operation.

The F4-Reset sequence operates on two levels:

- Clear Active Memory

The first F4-Reset deletes all the data currently in Active Memory, but leaves Datalogger data and all stored Site Setups intact. This is the most desirable method since all you have to do to restore operation is reload a saved Site Setup.

- Clear All Saved Memory

If the first sequence fails then you have to resort to the second level of the F4 sequence, which allows you to clear ALL Saved Memory. **Be aware that this erases all saved Site Setups (including flow calibrated sites), Datalogger Data and user-defined pipe and sensor tables.** This will require you to completely re-install the system and repeat all desired default settings, custom pipe tables, etc. The table below shows the sequence of the [F4] routine:

[Power On/Off + F4]⇒	[Clr Active Memory?]⇒	⇒No
	↑ ↓	⇒Yes
	[Clr Saved Data?]⇒	⇒No
		⇒Yes

### Clearing only Active Memory

1. Turn off power (if it is currently on). Press <F4> and keep it pressed while you turn on power. The prompt: [Clr Active Memory? No] appears at the top of the screen.
2. Press <Right Arrow> to access F4 Reset option list. Press <Down Arrow> to switch the option list to [Clr Active Memory? Yes]. Press <ENTER> to clear all Active Site Data (but not saved Site Setups).
3. To restore operation, press <MENU> to access the installation menu. Create a new site setup or recall a stored site setup.
4. Re-select any Meter Facilities menu items (e.g. RS-232 setup parameters).

### Clearing All Saved Data

1. Turn off power (if it is currently on).
2. Press <F4> and keep it pressed while you turn on power. The prompt: [Clr Active Memory? No] appears at the top of the screen. Press the <Down Arrow>. Note that the prompt switches to [Clr Saved Data? No].
3. To access the F4 Reset option list press the <Right Arrow>. Press the <Down Arrow> to switch the option list to [Clr Saved Data? Yes].



**NOTICE****Loss of RAM Data**

Before proceeding further it is essential to understand that this function eliminates ALL data stored in RAM. This means that all saved site setups including the site data of a flow-calibrated site will be erased! In addition, the entire Datalogger file plus any custom factory or user-created pipe or sensor tables will be eliminated.

The impact of this is such that we strongly recommend that you consult Technical Services before continuing with this procedure. Be aware that you will have to create a new Site Setup, re-enter all site specific parameters including pipe or sensor tables, plus all desired Meter Facilities menu entries.

4. To clear all Saved Memory press <ENTER>.
5. Create a Site Setup before attempting to access other menu items.
6. To restore operation, press <MENU> to access the installation menu. Create a new site setup and complete the installation procedure.
7. Re-select desired Meter Facilities menu items (e.g. RS-232 setup parameters).

## 10.3 Test Facilities Graph Screen

When operating in the transit time mode the Test Facilities Graph Screen is an exceptional diagnostic tool for troubleshooting problem applications or simply determining Receive signal quality. The primary function of this screen is to display the digitized receive signal waveform with the similar appearance and function of a digital oscilloscope. This screen also allows the user to override some of the flow meter default settings by permitting adjustment to the measured transit time, the digital averaging and the zero crossover used in the measurement of the up/down transit time difference. The figure shown below is a representation of the diagnostic graph.

**Note**

The Test Facilities Graph Screen requires significant CPU overhead. The flow meter should not be left in this mode during normal operation where the Datalogger is the primary output or during calibration work.

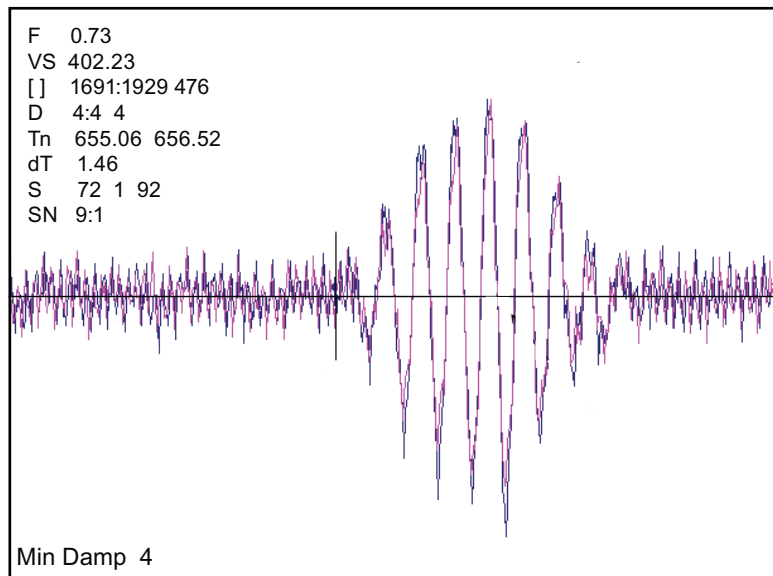

Figure 10-1 Test Facilities Graph Screen

### Entering the Diagnostic Graph Screen

Before you can view the Diagnostic Graph Screen the flow channel must first be properly installed and operating in a non-empty condition. If a previously installed channel is in a "Fault" condition, but not reporting "Empty", you can still access the Graph Screen to aid in troubleshooting the cause of the failure to measure flow.

To view the Graph Screen first enter the [Test Facilities] menu, which is a submenu of the main [Diagnostic Data] menu.

1. Pressing the <Up/Down Arrows>, scroll to the [Graph] menu item.
2. Press the <Right Arrow> to enter the [Graph] menu and scroll to highlight the [Yes] item in the option list.
3. Now press the <ENTER> key to access the Graph Screen.
4. To exit the Graph Screen and return to the main menu, press the <MENU> key once.

### Diagnostic Text Display

The text to the upper left-hand corner of the screen represents diagnostic items which can be individually turned on or off to reduce unnecessary clutter on the screen. This text display can be modified by pressing the <ENTER> key and scrolling up or down through the various parameters that appear in the Graph Display menu. Pressing the <ENTER> key will select the highlighted parameter (a "+" sign appears next to selected items) and pressing <CLR> will deselect the item. Pressing the <Left Arrow> will return you to the graph screen with the selected parameters appearing at the top left corner of the screen. (The sample graph above is shown with all diagnostics items selected).

## Time Base Control

The digitized receive signal can be moved either to the left or right on the screen by pressing the <Left> or <Right> keypad arrows. The direction of the arrow actually represents the direction in which the Receive "window" will move, thereby causing the receive signal to shift in the opposite direction on the screen (e.g., Pressing the <Left Arrow> moves the signal to the right).

The digitized receive signal can be expanded or contracted in the time domain by pressing the <+> or <-> keys on the keypad. This allows you to see the entire contents of the receive window, or zoom in to see greater detail. Pressing the <CLR> key once will automatically center the receive signal on the screen. When expanding the Receive signal small vertical "tick" marks will eventually appear. These marks represent the time at which the receive signal is digitally sampled.

## Correlated Plot

During conditions of flow, the actual transit time delta (difference) can be observed in the displayed receive signal waveform when the [Correlated Plot] menu parameter is not selected. To observe this time difference simply depress the <+> key (to see greater signal detail) until the individual up and down receive signals are clearly discernible. To verify that the flow meter signal processing algorithms are properly correlating the up and down stream receive signals, select the [Correlated Plot] option from the display menu list.

Return to the graph screen and observe the relative position of the up and down waveforms. In a properly correlated receive signal the two images should be nearly superimposed on top of each other, even during high flow conditions. In the unlikely situation where the two images appear to be offset by one or more receive cycles then the flow readings should be considered questionable.

## Command Modes

Although the flow meter signal processing algorithms are capable of accommodating a very wide range of signal conditions, it may be desirable to override these default settings under extremely difficult operating conditions. The following functions are available for this purpose.

## Digital Damping Control: (Hot Key 1 and 2)

The meter permits user modification of the digital averaging used by the signal processing routines. In general, the default damping values selected by the flow meter will provide optimal performance over a wide range of transit time applications. However, in extreme cases of unstable flow, pulsating flow, low signal levels or high electronic noise it may be necessary to override these default settings to permit uninterrupted and reliable flow measurement.

## Test Facilities Graph Screen

The Graph Screen includes the capability to access a set of command codes, which enable a user to override a number of default meter settings. The most important parameter is the digital damping control, which can be accessed by pressing number <1> or <2> on the keypad while in the Signal Graph Screen mode.

### [MinDamp #] Command

Pressing the <1> key will cause [MinDamp #] to appear on the command line at the lower left-hand corner of the screen. The number listed to the right of the command code represents the exponent in the meter exponential averaging routine, where the larger the number the greater the digital averaging. Pressing the <+> key will increase the damping value. Likewise, pressing the <-> key will decrease the damping value.

To exit this mode, press the <0> key on the keypad.

### [MaxDamp #] Command

Pressing the <2> key will bring up the [MaxDamp #] command. The function of this parameter is similar to the [MinDamp #] command described above; however, the two parameters interact in the following manner. The MinDamp value must not exceed the MaxDamp value; therefore increasing the MinDamp value above the previous MaxDamp value will set both parameters to the same value. In most cases, it is preferred that both damping parameters be set to the same value, however, in cases where rapid response to changes in liquid sound velocity for flow rate is required, the two values may be set differently. In this situation the meter will use the MaxDamp value when conditions are stable, but then switch to a faster damping value (limited by MinDamp) when a significant change in sound velocity or flow rate is perceived.

To exit this mode, press the <0> key on the keypad.

To access the Digital Damping Control using the Test Facilities Graph Screen, proceed as follows:

---

#### Note

To use the Test Facilities Graph Screen you must have a working site.

---

**To activate the Test Facilities Graph Screen:**

1. In the main menu, scroll to the [Diagnostic Data] menu and select [Test Facilities].
2. Scroll down to [Graph], press the <Right Arrow> and highlight [Yes]. Press <ENTER> to select.
3. The Test Facilities Graphic Screen will appear on the meter display as shown below.

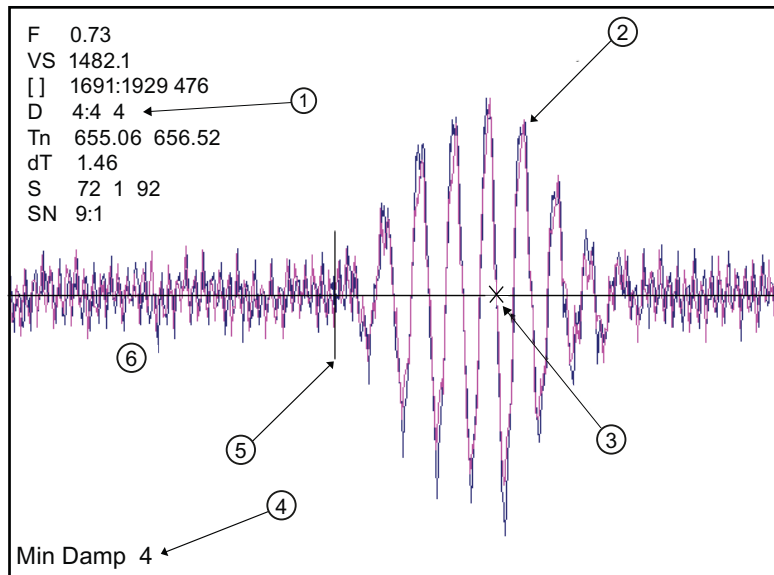

- |                            |                                  |
|----------------------------|----------------------------------|
| ① Damping Factors          | ④ Min Damping Factor (Hot Key 1) |
| ② Digitized Receive Signal | ⑤ TN Marker                      |
| ③ Crossover Marker         | ⑥ High Baseline Noise            |

Figure 10-2 Setting Digital Damping Factor

Setting the Digital Damping Factor to a value HIGHER than the default value of 4 may be necessary in cases where the signal-to-noise ratio (SN) is found to be unacceptably low (<15:1), but only if the noise is determined to be asynchronous (i.e., not associated with the transmit or flow meter timing circuitry) as shown in the signal example above, where the baseline noise has a higher frequency than the true liquid signal.

The following application conditions may require a higher Digital Damping Factor:

- Close proximity to pressure control valves which may generate in-band acoustic noise
- High un-dissolved gas solids content in liquid.
- High electronic noise from variable frequency drives or other external equipment.

**To INCREASE the Digital Damping:**

1. Press the <1> key while viewing the Test Facilities Graph Screen as shown above. The damping control [MinDamp #] will appear on the command line at the lower left-hand corner of the screen.

**Note**

The number listed to the right of the command code on the screen represents the exponent in the exponential averaging routine (digital damping), where the larger the number represents the greater the digital averaging. Setting this exponent higher than 7 is generally not recommended.

2. Pressing the <+> key will increase the MinDamp Factor by one unit for each key press. To exit this mode, press the <0> key on the keypad.

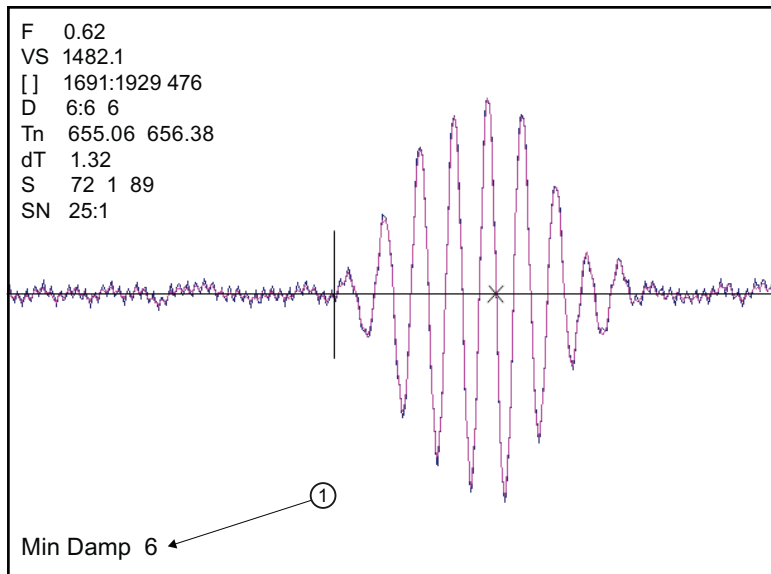

① Increased Damping Factor

Figure 10-3 Setting the MinDamp Factor

The above example shows that increasing the Digital Damping reduces asynchronous noise.

Setting the Digital Damping factor to a value LOWER than the default value of 4 may be justified in cases where pulsating flow is present (such as from a reciprocating pump) or for the purpose of diagnosing transient signal behavior. A pulsating flow condition that generates more than +/- 45 degrees of phase jitter will generally cause signal correlation problems when any digital averaging is used. In this case it may be necessary to completely eliminate the digital averaging by reducing the Digital Damping Factor to 0.

**To DECREASE the Digital Damping:**

1. Press the <2> key while viewing the Test Facilities Graph Screen. The damping control [MaxDamp #] will appear on the command line at the lower left-hand corner of the screen.
2. Pressing the <-> key will decrease the MaxDamp Factor by one unit for each key press. To exit this mode, press the <0> key on the keypad.

### **Transit Time Adjustment: (Hot Key 3)**

Observe the short vertical marker at the beginning of the receive signal in the Graph Screen above. This line represents the position in time ( $T_n$ ) where the flow meter perceives the arrival of the ultrasonic signal. There are actually two  $T_n$  markers, one for the upstream arrival time and one for the downstream arrival time. For proper liquid sound velocity measurement these  $T_n$  markers should be positioned near the beginning edge of the receive waveform envelope (as shown), however, in cases of poor signal conditions it is possible for this measurement to be off by several receive waveform cycles.

1. To adjust the  $T_n$  mark position press the <3> key on the keypad to bring up the [TnSet #] command.
2. Pressing the <+> or <-> keys will cause the  $T_n$  marker to move later or earlier, respectively. As you adjust the  $T_n$  marker, both  $T_n$  and  $V_s$  (liquid sound velocity) will change accordingly.
3. To exit this mode, press the <0> key on the keypad.

### **Zero Crossover Adjustment: (Hot Key 4)**

Observe the small "X" mark located on the zero crossing line near the middle of the receive signal in the Graph Screen above. This "X" indicates the central crossover which the flow meter is using to measure the transit-time delta. This crossover will generally be close to the peak of the Receive signal with at least one well formed (non-aberrated) receive cycle on each side of the crossover.

1. If it appears that the placement of this crossover is unsatisfactory then it can be adjusted by pressing the <4> key on the keypad, which will invoke the [ZCO Set #] command. The crossover point can then be moved in either direction on the waveform using the plus <+> or minus <-> keys. The change from the default value (in receive cycles) will appear in the number to the right of the command.
2. To exit this mode, press the <0> key.

### Envelope Threshold Adjustment: (Hot Key 5 & 6)

Pressing the <=> key causes the graph to toggle between the default signal waveform screen and the signal envelope screen (see example below). This envelope screen can aid in the diagnosis of Tn errors caused by unusual receive waveform distortion. Signal distortion is sometimes caused by poor sensor selection or poor pipe wall conditions, which may result in an incorrectly measured fluid sound velocity. To improve the automatic measurement of Tn, the envelope threshold limit can be adjusted to exclude portions of the envelope, which may be causing the Tn detection problem.

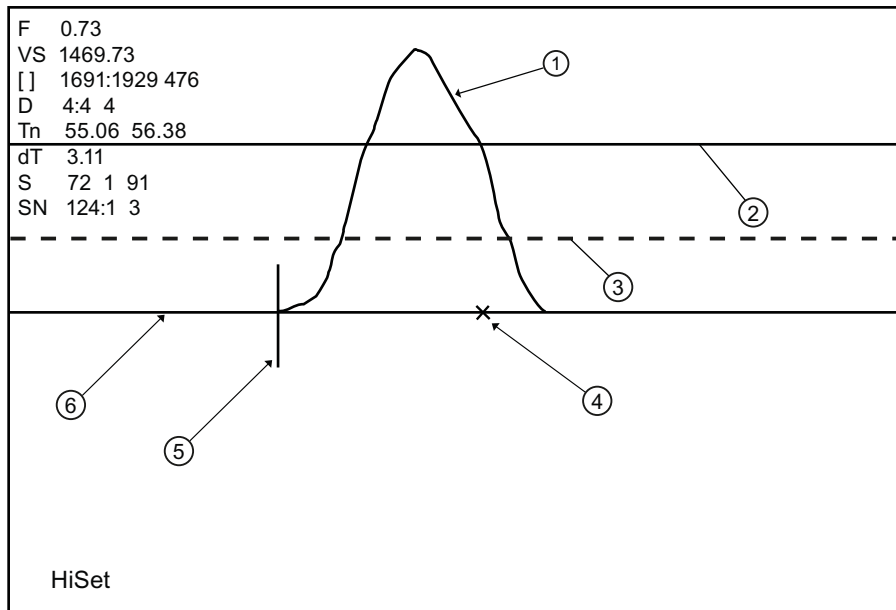

- |                            |                    |
|----------------------------|--------------------|
| ① Envelope Signal          | ④ Crossover Marker |
| ② HiSet Envelope Threshold | ⑤ TN Marker        |
| ③ LoSet Envelope Threshold | ⑥ Zero Baseline    |

Figure 10-4 Envelope Threshold Adjustment

1. If it appears that the default placement of the Tn marker is incorrect or unstable, it can be adjusted by pressing the <5> key on the keypad to invoke the [Hi Set #] command or by pressing the <6> key to invoke the [Low Set #] command (while viewing the envelope screen). A horizontal line representing the envelope threshold level will appear along with a number indicating the percentage level. The High and Low thresholds can then be moved either up or down on the envelope using the <+> or <-> keys. While viewing the Tn marker position, adjust the thresholds so that they are well above the baseline "noise" level but below the first major peak.
2. To exit this mode, press the <0> key.



### Signal Masking Function: (Hot Key 7)

Under conditions of extremely low signal amplitude, a noise spike associated with the flow meter receive signal window may be present on the extreme left side of the graph display. If this spike is large enough it may interfere with the signal detection routines.

1. To eliminate this noise from the signal processing routines, press the <7> key to invoke the [Mask Set #] command, then press the <+> key until the noise is no longer present in the receive waveform.
2. Press <0> to exit this command.

### Hold Set Function: (Hot Key 8)

The [Hold Set #] command is used to set the Hold Set number higher if intermittent mis-registration occurs. Press the <8> key on the keypad to invoke this function.

Table 10- 2 Description of Graph Screen Text Display Parameters

Screen Text Parameters	Menu List Item	Description
F	Flow	Measured flow rate in selected flow units.
VS	Vs m/s	Sound Velocity in meters per second.
[ ]	Display Metrics	Represents the digital sample position of the receive window.
	Correlated plot	Displays the receive waveform in its proper superposition or registration. The true delta time will be displayed by NOT selecting "Correlated Plot".
	Centroid Mark	Indicates with a large vertical marker the peak energy of the receive waveform.
D	Damping	Displays the minimum and maximum digital damping exponent along with the active damping exponent.
Tn	Tn (usec)	Receive signal transit time in microseconds.
dT	DeltaT (nsecs)	Transit time delta (difference) in nanoseconds.
S	Signal Strength	Displays %Valc (amplitude), %Vaer (aeration factor) and numeric ALC.
SN	Signal-to-Noise Ratio	Indicates the signal to noise ratio of the receive signal. Increased damping will increase the S/N ratio as the asynchronous noise reduces.
	Envelope	Percentage change of the signal from Initial Makeup conditions.

Table 10- 3 Hot Key Summary

Key	Command Line	Description
<+>		Expands (magnifies) waveform to view more detail.
<->		Contracts waveform to view more of the waveform.
<Left Arrow>		Shifts receive window to the left (waveform to the right).
<Right Arrow>		Shifts receive window to the right (waveform to the left).
<CLR>		Brings waveform to the center of the screen.
<ENTER>		Calls up Text Display menu items. <Left Arrow> to return to graph.
<MENU>		Exits the Graph Screen and returns to the main menu.
<1>	MinDamp	Minimum damping exponent control (+ or - to increase or decrease).
<2>	MaxDamp	Maximum damping exponent control (+ or - to increase or decrease).
<3>	TnSet	Transit time adjustment (use + or - to move Tn marker).
<4>	ZCOSet	Zero Crossover adjustment (use + or - to move crossover marker).
<5>	HiSet	Signal envelope threshold level (use + or - to move threshold).
<6>	LoSet	Signal envelope threshold level (use + or - to move threshold).
<7>	MaskSet	Leading edge masking functions (use + or - to alter number of samples masked).
<8>	Hold Set	Set this number higher if intermittent mis-registration occurs.
<0>		Exits the command line.
<=>		Toggle graph between receive waveform and envelope waveform.
<F1> and <.>		Dumps the digitized waveform data over the RS-232 port. You must first leave the Graph Screen mode before invoking this command.

## 10.4 Site Setup Data

This menu provides data pertaining to sensor characteristics and operation. Some menu items are for technical support interpretation only.

Siemens	Dual Path [1]	ABC
<b>Current transmit drive code</b>		
fx (drive)		30
N (burst length)		5
Ltn		-1.154
Vf max		1577.42
Vs max M/S		2165.41
Vs min M/S		939.62
Empty		30
Samples/Cycle		16
Max Damping		
Min Damping		
HF		0.120
<b>Site Setup Data</b>		

Table 10- 4 Site Setup Menu Items

fx Drive	Current Transmit drive code selected during Initial Makeup. The drive code controls the sonic transmit signal.
N (burst length)	Transmit burst duration selected during Initial Makeup. To change N count press <Right Arrow>. At equal sign enter numeric value (1 to 9 only).
Ltn (mm/in)	Spacing distance between the sensors. It will be in inches or millimeters, depending on default units.
Vf max	The flow velocity (in selected units) corresponding to one whole cycle offset between upstream and downstream receive signals.
Vs max M/S	Maximum Vs for current sensor spacing.
Vs min M/S	Minimum Vs for current sensor spacing.
Empty	Value of Empty Alarm Setting. The meter will declare an empty status if signal strength drops below this value.
Samples/Cycle	Digital sampling rate.
Max Damping	Maximum signal damping. Use to average digital data when an unstable condition occurs.
Min Damping	Minimum signal damping. Use to average digital data when an unstable condition occurs.
HF	Flow registration correction parameter.

### [HF] Menu Item

The flow meter includes a Diagnostics Menu item that permits the entry of a flow registration correction parameter labeled [HF]. This "HF" parameter is the input for a proprietary algorithm that automatically compensates for signal beam blowing, thereby extending the upper flow limit of the flow meter. The HF parameter should only be adjusted in cases where the user suspects that extreme flow velocity or a large delta-time may be causing signal correlation problems.

### Using the [HF] Menu Cell

Two methods for adjusting this parameter are provided via the [HF] menu cell, located within the [Diagnostics] / [Site Setup] submenu. The "Manual" method provides direct entry of this parameter and is primarily intended for the advanced user, whereas the "Automatic" method allows the flow meter to automatically measure the required correction and install the parameter.

### Guidelines for use

- This menu is only accessible for the sensor channels, not the virtual (average flow) channel of the flow meter (i.e., Diagnostics Path 1 or Path 2, but not Path 1 & 2).
- The flow meter will inhibit the "Automatic" installation of the [HF] parameter if the flow rate is insufficient (too low) to accurately measure the required correction. If the maximum flow rate for the application is relatively low then this correction is not be required.
- If the flow rate is very high and the flow meter is reporting erroneous or unstable flow, then the flow meter may already be having trouble resolving the upstream and downstream signals. In this event, it may be necessary to first lower the flow rate to a moderate level before performing the "Automatic" HF adjustment. Once this is done the flow meter should be able to properly measure the highest flow rates without problems.
- The limits of the "HF" parameter are +/- 0.7 and any attempt to manually install a larger value will cause the flow meter to abort the installation of the parameter.

---

#### Note

Pressing the <Left Arrow> at any stage prior to accepting the measured value will abort the installation and return to the previous setting.

---

### Accessing the [HF] Function

1. At the [Meter Type] Menu, press the <Right Arrow> and then <ENTER> to select the desired Path (e.g., Dual Path Flow).
2. In the [Dual Path Flow] Menu, press the <Down Arrow> and scroll to the [Diagnostic Data] menu cell. Press the <Right Arrow> to select it.
3. In the [Diagnostic Data] Menu, highlight [Path Select] and select the desired sensor path. Press <ENTER> to select path.
4. Press the <Down Arrow> and scroll to the [Site Setup Data] menu cell. Press the <Right Arrow> to select it.

### Manual Adjustment Procedure

1. In the [Site Setup Data] Menu, press the <Down Arrow> and scroll to the [HF] menu cell. Press the <Right Arrow> and a pop-up [Manual] prompt will appear as shown below.

---

**Note**

Press the <Up/Down Arrow> to select [Automatic], if desired.

---

2. Use the numerical keys to input the desired correction value. Press <ENTER> to input value.

Siemens	Dual Path [1]	ABC
fx (drive)		29
N (burst length)		5
Ltn		5.136
Vf max	1577.4	Adjustment
Vs max M/S		>Manual 41
Vs min M/S		939.62
Empty		
Samples/Cycle		29
Max Damping		
Min Damping		
HF		>0.000

Site Setup Data

Siemens	Dual Path [1]	ABC
fx (drive)		29
N (burst length)		5
Ltn		5.136
Vf max	1577.4	>Manual
Vs max M/S		= 0.120 41
Vs min M/S		939.62
Empty		
Samples/Cycle		29
Max Damping		
Min Damping		
HF		>0.000

Site Setup Data

3. The new correction value will appear next to the [HF] menu cell as shown below.

Siemens	Dual Path [1]	ABC
fx (drive)		29
N (burst length)		5
Ltn		5.136
Vf max		
Vs max M/S		
Vs min M/S		1355.00
Empty		
Samples/Cycle		29
Max Damping		
Min Damping		
HF		>0.120

Site Setup Data

### Automatic Adjustment Procedure

1. In the [Site Setup Data] Menu, press the <Down Arrow> and scroll to the [HF] menu cell. Press the <Right Arrow> and a pop-up [Manual] prompt will appear.
2. Press the <Up or Down Arrow> to select [Automatic] then press <ENTER>.
3. The current measured correction value is displayed (see below).
4. Press <ENTER> again to install this correction value which will now appear next to the [HF] menu cell.

---

#### Note

The value shown in the [Automatic] pop-up prompt can not be changed and is for user information only.

---

Siemens	Dual Path [1]	ABC
fx (drive)		29
N (burst length)		5
Ltn		5.136
Vf max	Adjustment	
Vs max M/S	>Automatic	
Vs min M/S		939.62
Empty		
Samples/Cycle		29
Max Damping		
Min Damping		
HF		>0.000
<b>Site Setup Data</b>		

Siemens	Dual Path [1]	ABC
fx (drive)		29
N (burst length)		5
Ltn		5.136
Vf max	>Automatic	
Vs max M/S	= 0.026	
Vs min M/S		939.62
Empty		
Samples/Cycle		29
Max Damping		
Min Damping		
HF		>0.026
<b>Site Setup Data</b>		

- If you decide not to use the [Automatic] selection, press any key other than <ENTER> to abort the operation.

## 10.5 Force Transmit

### NOTICE

#### Incorrect Diagnostic Procedures

The Force Transmit and Force Frequency diagnostic procedures are preconfigured at the factory and should only be implemented by approved Siemens personnel otherwise damage to the equipment may occur.

Restrict use and repair to qualified personnel.

This diagnostic software routine allows the user to "force" a transmitting condition that can be used to search for an amplitude level (ALC) when Detection Fault or Low Signal alarms are present. The routine forces the flow meter to generate constant transmit bursts while reporting current receive signal strength for the user. To initiate the Force Transmit function, refer to the Short Burst detection mode example shown below.

**Setting a Force Transmit condition**

1. After [Install] command is invoked and while the flow meter is going through the drive selections press the <ALT> and <MENU> keys simultaneously.

Siemens	Dual Path [1]	ABC	Siemens	Dual Path [1]	ABC
<b>Install Completed?</b>			<b>Drive 0</b>		
Install Path	1		Install Path	1	
Sensor Model	1011HP-T1		Sensor Model	1011HP-T1	
Sensor Size	B3		Sensor Size	B3	
Sensor Mount Mode	Direct		Sensor Mount Mode	Direct	
Spacing Offset	Minimum		Spacing Offset	Minimum	
Number Index	4		Number Index	4	
Spacing Method	Spacer Bar 1012TP		Spacing Method	Spacer Bar 1012TP	
Ltn Value (in)	0.217		Ltn Value (in)	0.217	
<b>Install Complete</b>	No		<b>Install Complete</b>	Install	
Empty Pipe Set	Channel Not Setup		Empty Pipe Set	Channel Not Setup	
Zero Flow Adjust	Channel Not Setup		Zero Flow Adjust	Channel Not Setup	
<b>Install Sensor</b>			<b>Install Sensor</b>		

**Note**

The <ALT> and <MENU> keys must be pressed before the flow meter scans through all the drives, or the Force Transmit function must be initiated again.

2. A typical menu screen will appear as shown below and indicate the current ALC (e.g., 50). This ALC number indicates the current receive signal strength and can be used for further diagnostic purposes.

Siemens	Dual Path [1]	ABC	Siemens	Dual Path [1]	ABC
<b>ForceN</b>	fx=8	m=7	ALC=50		
Install Path	1		Install Path	1	
Sensor Model	1011HP-T1		Sensor Model	1011HP-T1	
Sensor Size	B3		Sensor Size	B3	
Sensor Mount Mode	Direct		Sensor Mount Mode	Direct	
Spacing Offset	Minimum		Spacing Offset	Minimum	
Number Index	4		Number Index	4	
Spacing Method	Spacer Bar 1012TP		Spacing Method	Spacer Bar 1012TP	
Ltn Value (in)	0.217		Ltn Value (in)	0.217	
<b>Install Complete</b>	Install		<b>Install Complete</b>	Install	
Empty Pipe Set	Channel Not Setup		Empty Pipe Set	Channel Not Setup	
Zero Flow Adjust	Channel Not Setup		Zero Flow Adjust	Channel Not Setup	
<b>Install Sensor</b>			<b>Install Sensor</b>		

3. To exit Force Transmit, press the <Left Arrow> and a Detection Fault prompt will appear (see above).
4. Press the <Left Arrow> again and the meter will return to the [Install Sensor] menu and highlight the [Empty Pipe Set] menu cell.



### **Setting a Forced Frequency**

1. To force a frequency, repeat steps 1 and 2 above, but press <Right Arrow>. The following typical display line will appear: **Drive =0**
2. Using numeric keys enter the frequency and press <ENTER>.
3. To complete the Install process after mounting the transducers press <ENTER>.
4. If the Force Transmit diagnostic procedure is not used, the normal [Install Complete] function occurs.



## Technical data

### 11.1 Technical Data

Temperature Range	Degree of Protection
Operating: -18°C to 60°C (0°F to 140°F) Storage: -20°C to 60°C (-4°F to 140°F)	IP65 (NEMA 4X)

### Performance

The following specifications apply under standard conditions (i.e., measurements taken on a straight run of 15 diameters upstream and 5 diameters downstream; flow rate above 1 fps; non-aerated Newtonian liquids flowing at Reynolds numbers <2000 or >10000).

Table 11- 1 Performance Specifications

Transit-Time Accuracy	At least $\pm 1\%$ to $\pm 2\%$ of indicated flow (better than $\pm 0.5\%$ possible with calibration.)
Flow Sensitivity	0.0003 m/s (0.001 fps) - even at zero flow.
Zero Drift Stability	Less than 0.005 m/s (0.015 fps)
Batch Repeatability	$\pm 0.15\%$ of flow
Response Rate (Damping)	SmartSlew effective from 0.2 seconds to 5 minutes.
Flow Velocity Range	Min. $\pm 12$ m/s ( $\pm 40$ ft/s), inc. zero flow
Linearity	0.001 m/s (0.003 ft/s)
Flow Profile Compensation	Automatic Reynolds number correction of reported flow rate.



## Appendix

### A.1 Certificates

Certificates are posted on the Internet and on the manual collection shipped with the device.

#### See also

Certificates (<http://www.siemens.com/processinstrumentation/certificates>)

### A.2 Ordering

In order to ensure that the ordering data you are using is not outdated, the latest ordering data is always available on the Internet: Catalog process instrumentation (<http://www.siemens.com/processinstrumentation/catalogs>)

#### See also

Process instrumentation catalog (<http://www.siemens.com/processinstrumentation/catalogs>)

### A.3 I/O Connections and Wiring

#### Terminal Block Wiring - 7ME39400AL00 and 7ME39400AL01 I/O Module

(Refer to manual drawing 1010N-2-7 sheet 2 of 2)

These connection diagrams apply to the part numbers listed below.

Table A- 1 Connection Diagrams and Part Numbers

1010N-2-7 (Sheet 2 of 2) Drawing	
FUS1010	7ME3530, 7ME3533
FUE1010	7ME3500
FUH1010	7ME3600, 7ME3603

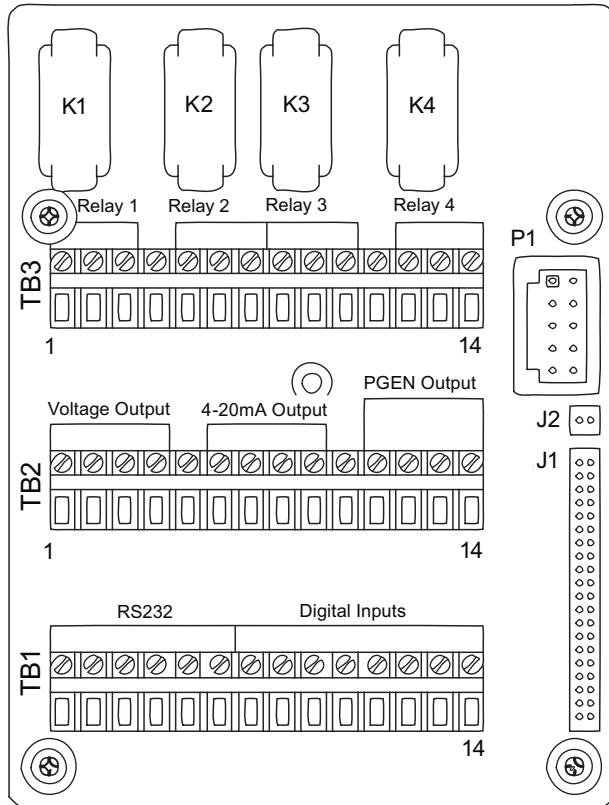
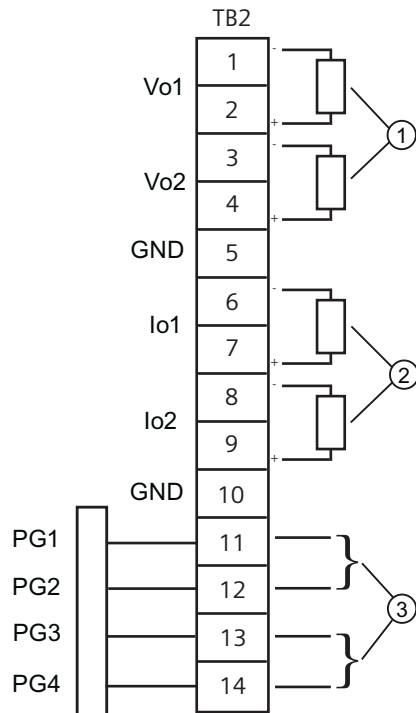

Figure A-1 7ME39400AL00 and 7ME39400AL01 I/O Module

Table A-2 Input/Output Wiring (TB2) - 7ME39400AL00 and 7ME39400AL01 I/O Module (for 7ME3500 or 7ME3530 only)

Pin#	Signal	Description	Definition	Function
1	Vo1+	Meter process variables are assigned to individual outputs under menu control.	0-10 Volt Analog Output	System outputs assignable and scalable to flow related parameters. CGND is for cable shield terminations. 4-20mA outputs also provide a fault indication by dropping to 2mA if assigned to flow rate and under fault conditions.
2	Vo1-		Ref. Ground	
3	Vo2+		0-10 Volt Analog Output	
4	Vo2-		Ref. Ground	
5	CGND		Chassis GND	
6	Io1+		4-20mA Output 1	
7	Io1-		Isolated Return	
8	Io2+		4-20mA Output 2	
9	Io2-		Isolated Return	
10	CGND		Chassis GND	
11	PG1	0 -5000 Hz Frequency output; assignable.	Frequency Output 1	5V TTL
12	PG2		GND	GND
13	PG3		Frequency Output 2	5V TTL
14	PG4		GND	GND



① 0-10VDC, Load 10k ohm (min)

② 4-20mA Load 1k ohm (max)

③ Note: 7ME360x only, Totalizer pulses

TB2-11 - NEG [-] Total OC (GND TB2-2 or TB2-4)

TB2-12 - NEG [-] Total TTL (GND TB2-2 or TB2-4)

TB2-13 - POS [+] Total OC (GND TB2-2 or TB2-4)

TB2-14 - POS [+] Total TTL (GND TB2-2 or TB2-4)

A.3 I/O Connections and Wiring

Table A- 3 Input/Output Wiring (TB3) - 7ME39400AL00 and 7ME39400AL01 I/O Module

Pin#	Signal	Definition	Description	Function Single Channel	Function Dual Channel	Function Dual Path	Function Dual Path Only
1	K1 A	Relay 1 Normally Open	Relay 1	Alarm or control functions set by CH 1	Alarm or control functions set by CH 1	Alarm or control functions set by CH 3	Alarm or control functions set by CH 3
2	K1 B	Relay 1 Normally Closed (7ME39400AL01 only)					
3	K1 C	Relay 1 Common					
4	GND	Digital Return [GND]	GND	GND	GND	GND	GND
5	K2 A	Relay 2 Normally Open	Relay 2	Alarm or control functions set by CH 1	Alarm or control functions set by CH 1	Alarm or control functions set by CH 3	Alarm or control functions set by CH 3
6	K2 B	Relay 2 Normally Closed (7ME39400AL01 only)					
7	K2 C	Relay 2 Common					
8	K3 A	Relay 3 Normally Open	Relay 3	Alarm or control functions set by CH 1	Alarm or control functions set by CH 2	Alarm or control functions set by CH 3	Alarm or control functions set by CH 3
9	K3 B	Relay 3 Normally Closed (7ME39400AL01 only)					
10	K3 C	Relay 3 Common					
11	GND	Digital Return [GND]	GND	GND	GND	GND	GND
12	K4 A	Relay 4 Normally Open	Relay 4	Alarm or control functions set by CH 1	Alarm or control functions set by CH 2	Alarm or control functions set by CH 3	Alarm or control functions set by CH 3.
13	K4 B	Relay 4 Normally Closed (7ME39400AL01 only)					
14	K4 C	Relay 4 Common					



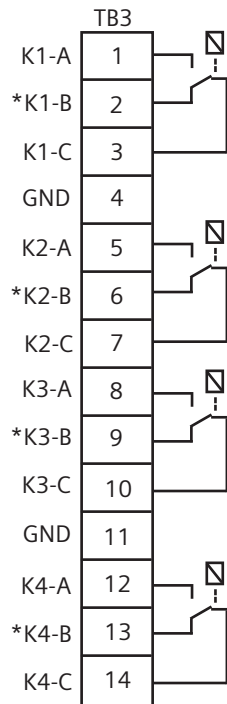

**Note**

Relays shown in Power OFF position, which is the same as the alarm assertion position.

\*7ME39400AL00 Mercury Relay only available with Normally Open.

**Terminal Block Wiring - 7ME39400AL03 and 7ME39400AL04 Expanded I/O Module**

(Refer to manual drawing 1010N-7-7 sheet 2 of 2)

These connection diagrams apply to the part numbers listed below.

Table A- 4 Connection Diagrams and Part Numbers

1010N-7-7 (Sheet 2 of 2) Drawing	
FUS1010	7ME3530, 7ME3533
FUE1010	7ME3500
FUH1010	Not Used

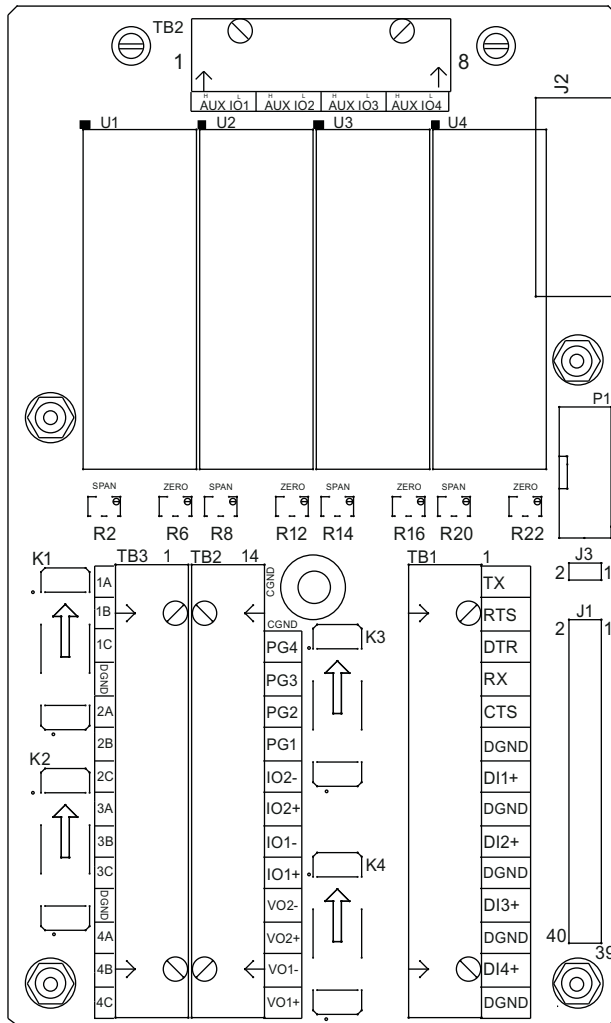
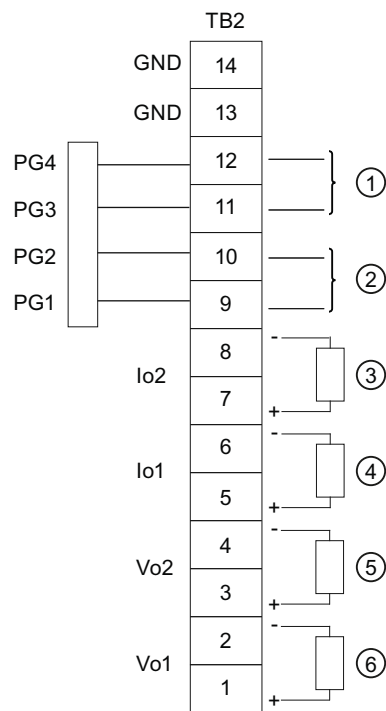

Figure A-2 7ME39400AL03 and 7ME39400AL04 Expanded I/O Module

Table A- 5 Input/Output Wiring (TB2) - 7ME39400AL03 and 7ME39400AL04 Expanded I/O Module

Pin#	Signal	Definition	Description	Function Dual/Quad Path Only
14		Chassis Ground	Chassis Ground	Cable Shield Terminations
13		Chassis Ground	Chassis Ground	Cable Shield Terminations
12	PG4	GND	0-5000 Hz frequency output , assignable	GND
11	PG3	TTL		5V TTL
10	PG2	GND		GND
9	PG1	TTL		5V TTL
8	Io2 (-)	Isolated Return	Flow meter process variables assigned to individual outputs under menu control.	System outputs assignable & scalable to flow related parameters. 4-20mA outputs also provide a fault indication by dropping to 2mA if assigned to flow rate and under fault conditions.
7	Io2 (+)	4-20mA Output 2		
6	Io1 (-)	Isolated Return		
5	Io1 (+)	4-20mA Output 1		
4	Vo2-	Ref. Ground		
3	Vo2+	0-10 Volt Output		
2	Vo1-	Ref. Ground		
1	Vo1+	0-10 Volt Output		



- ① TB2-11 - POS [+] Total OC  
TB2-12 - POS [+] Total TTL
- ② TB2-9 - NEG [-] Total OC  
TB2-10 - NEG [-] Total TTL
- ③ 4-20mA Load 1k ohm (max)

- ④ 4-20mA Load 1k ohm (max)
- ⑤ 0-10V Load 10k ohm (min)
- ⑥ 0-10V Load 10k ohm (min)

Appendix

A.3 I/O Connections and Wiring

Table A- 6 Input/Output Wiring (TB3) - 7ME39400AL03 and 7ME39400AL04 Expanded I/O Module

Pin#	Signal	Definition	Description	Function Dual Path Only	Function Quad Path Only
1	K1 A	Relay 1 Normally Open	Relay 1	Alarm or control functions set by CH 3	Alarm or control functions set by CH5
2	K1 B	Relay 1 Normally Closed (7ME39400AL04 only)			
3	K1 C	Relay 1 Common			
4	GND	Digital Return (GND)	DGND		
5	K2 A	Relay 2 Normally Open	Relay 2	Alarm or control functions set by CH 3	Alarm or control functions set by CH5
6	K2 B	Relay 2 Normally Closed (7ME39400AL04 only)			
7	K2 C	Relay 2 Common			
8	K3 A	Relay 3 Normally Open	Relay 3	Alarm or control functions set by CH 3	Alarm or control functions set by CH5
9	K3 B	Relay 3 Normally Closed (7ME39400AL04 only)			
10	K3 C	Relay 3 Common			
11	GND	Digital Return (GND)	DGND		
12	K4 A	Relay 4 Normally Open	Relay 4	Alarm or control functions set by CH 3	Alarm or control functions set by CH5
13	K4 B	Relay 4 Normally Closed (7ME39400AL04 only)			
14	K4 C	Relay 4 Common			

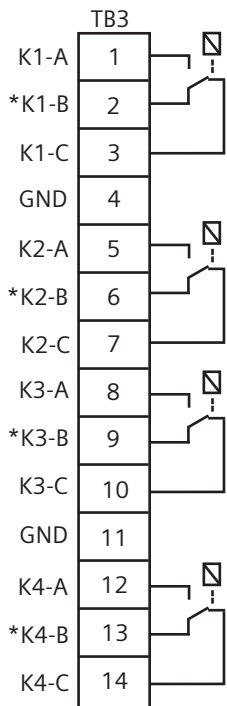

**Note**

Relays shown in Power OFF position, which is the same as the alarm assertion position.

\*7ME39400AL03 Mercury Relay only available with Normally Open.

Table A- 7 Input/Output Wiring (TB4) - 7ME39400AL03 and 7ME39400AL04 Expanded I/O Module

Pin#	Signal	Definition	Description	Single CH Function	Dual CH Function	Dual Path Function	Dual Path Only Function	Quad Path Only Function
1	AUX I01+	Isolated Loop Supply Io1	Io1 External Power	+30V max. supply voltage allowed			Not Used	
2	AUX I01-	Io1 4-20mA Output	Io1 Signal	Same output assignment as TB2-9				
3	AUX I02+	Isolated Loop Supply Io2	Io2 External Power	+30V max. supply voltage allowed				
4	AUX I02-	Io2 4-20mA Output	Io2 Signal	Same output assignment as TB2-11				
5	AUX I03+	Isolated Loop Supply Io3	Io3 External Power	System outputs assignable and scalable to flow related parameters. 4-20mA outputs also provide a fault indication by dropping to 2mA if assigned to flow rate and under fault conditions.			+30V max. Same as TB2-1	
6	AUX I03-	Io3 4-20mA Output	Io3 Signal					
7	AUX I04+	Isolated Loop Supply Io4	Io4 External Power					
8	AUX I04-	Io4 4-20mA Output	Io4 Signal				+30V max. Same as TB2-3	

**Note**

Auxiliary 4-20mA loops are assigned and spanned under menu control of Vo and PGEN outputs.

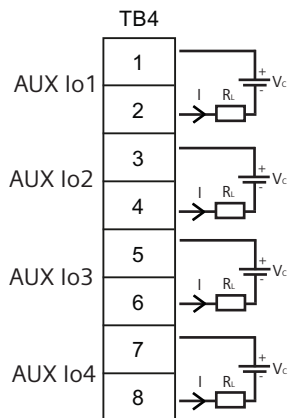

Vc: 24 VDC typical (+15VDC to 30VDC max) Loop Supply

$R_L$ : 1000 ohms max, = Loop wire resistance plus user's input load resistance

I: 4-20mA

### Terminal Block Wiring - 7ME39400AL04 Expanded I/O Module

(Refer to manual drawing 1010N-7-7 sheet 2 of 2)

These connection diagrams apply to the part numbers listed below.

Table A- 8 Connection Diagrams and Part Numbers

1010N-7-7 (Sheet 2 of 2) Drawing	
FUH1010	7ME3600, 7ME3603
FUS1010	Not Used
FUE1010	Not Used

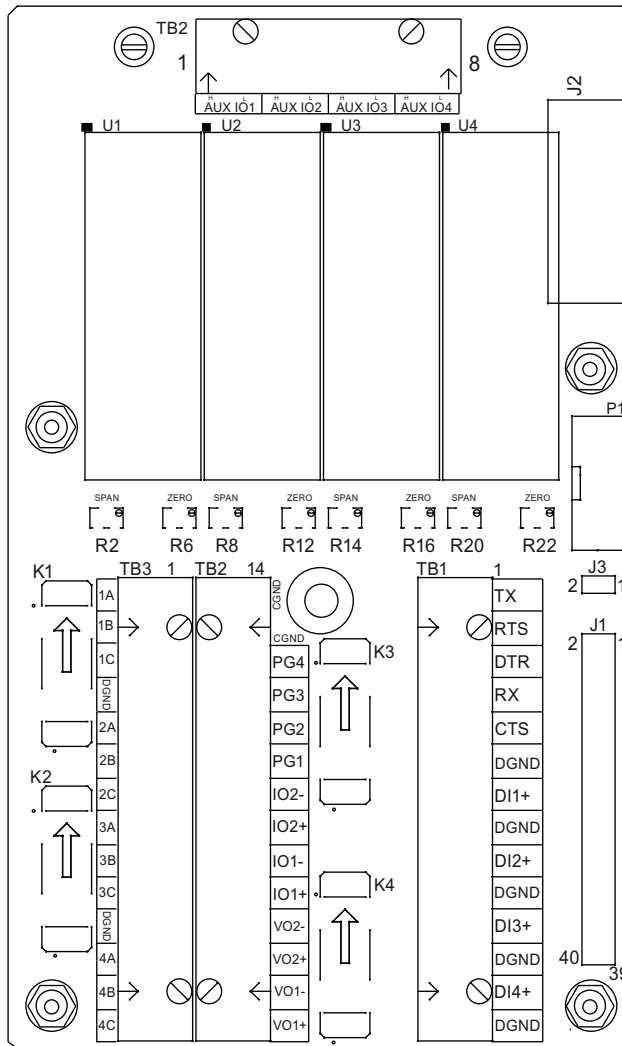

Figure A-3 7ME39400AL04 Expanded I/O Module

A.3 I/O Connections and Wiring

Table A-9 Input/Output Wiring (TB2) - 7ME39400AL04 Expanded I/O Module

Pin#	Signal	Definition	Description	Function Dual/Quad Path Only
14		Chassis Ground	Chassis Ground	Cable Shield Terminations
13		Chassis Ground	Chassis Ground	Cable Shield Terminations
12	PG4	POS [+] Total TTL	Totalizer Pulses, scalable	POS [+] Total TTL
11	PG3	POS [+] Total OC		POS [+] Total OC
10	PG2	NEG [-] Total TTL		NEG [-] Total TTL
9	PG1	NEG [-] Total OC		NEG [-] Total OC
8	Io2 (-)	Isolated Return	Flow meter process variables assigned to individual outputs under menu control.	System outputs assignable & scalable to flow related parameters.
7	Io2 (+)	4-20mA Output 2		
6	Io1 (-)	Isolated Return		
5	Io1 (+)	4-20mA Output 1		
4	Vo2-	Ref. Ground	4-20mA outputs also provide a fault indication by dropping to 2mA if assigned to flow rate and under fault conditions.	OC = Open Collector
3	Vo2+	0-10 Volt Output		
2	Vo1-	Ref. Ground		
1	Vo1+	0-10 Volt Output		

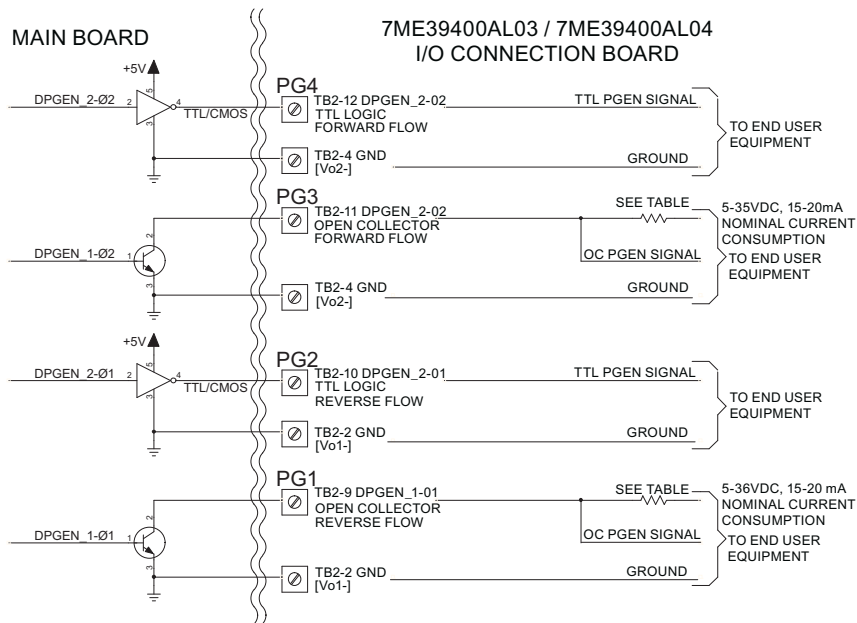



Table A- 10 Open Collector User Resistor Recommendations

User Supply Voltage (VDC)	External Resistor (Ohms)	Expected Current Draw (mA)	Recommended Resistor Wattage (Watts)
5	270	18.5	1/2
9	510	17.6	1/2
12	680	17.6	1/2
18	1000	18	3/4
24	1500	16	1
28	1800	15.5	1 1/4
36	2400	15	1 1/4

**Note**

TB2-9 and TB2-11 are Open Collector Outputs that require external pull-up resistors for operation. See table for External Supply Voltage and suggested resistor value and ratings. Maximum current into the transistor is 100mA. Maximum Voltage is +36 VDC.

**NOTICE****Transistor Damage**

Negative voltages with respect to ground will permanently damage transistors.

Use caution when applying power to circuit boards.

Appendix

A.3 I/O Connections and Wiring

Table A- 11 Input/Output Wiring (TB3) - 7ME39400AL04 Expanded I/O Module

Pin#	Signal	Definition	Description	Function Dual Path Only	Function Quad Path Only
1	K1 A	Relay 1 Normally Open	Relay 1	Alarm or control functions set by CH 3.	Alarm or control functions set by CH 5.
2	K1 B	Relay 1 Normally Closed (7ME39400AL04 only)			
3	K1 C	Relay 1 Common			
4	GND	Digital Return (GND)	DGND		
5	K2 A	Relay 2 Normally Open	Relay 2	Alarm or control functions set by CH 3.	Alarm or control functions set by CH 5.
6	K2 B	Relay 2 Normally Closed (7ME39400AL04 only)			
7	K2 C	Relay 2 Common			
8	K3 A	Relay 3 Normally Open	Relay 3	Alarm or control functions set by CH 3.	Alarm or control functions set by CH 5.
9	K3 B	Relay 3 Normally Closed (7ME39400AL04 only)			
10	K3 C	Relay 3 Common			
11	GND	Digital Return (GND)	DGND		
12	K4 A	Relay 4 Normally Open	Relay 4	Alarm or control functions set by CH 3.	Alarm or control functions set by CH 5.
13	K4 B	Relay 4 Normally Closed (7ME39400AL04 only)			
14	K4 C	Relay 4 Common			

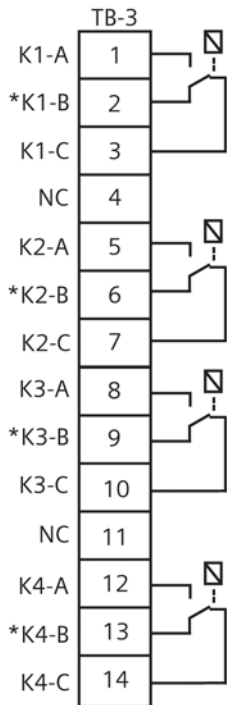

**Note**

Relays shown in Power OFF position, which is the same as the alarm assertion position.

\*7ME39400AL03 Mercury Relay only available with Normally Open.

Table A- 12 Input/Output Wiring (TB4) - 7ME39400AL04 Expanded I/O Module

Pin#	Signal	Function	Description
1		No Connection	
2		No Connection	
3		No Connection	
4		No Connection	
5	AUX 103+	Isolated Loop Supply	Connect +30V max. Loop Supply here
6	AUX 103-	Loop-Powered 4-20mA	PGEN 1 Data Presented as 4-20mA
7	AUX 104+	Isolated Loop Supply	Connect +30V max. Loop Supply here
8	AUX 104-	Loop-Powered 4-20mA	PGEN 2 Data Presented as 4-20mA

**Note**

Auxiliary 4-20mA loops are assigned and spanned under menu control of Vo and PGEN outputs.

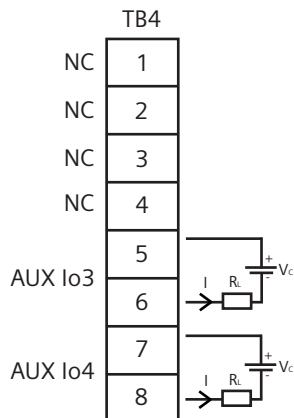

Vc: 24 VDC typical (+15 VDC to +30 VDC max) Loop Power

RL: 1000 ohms (max), Loop wire resistance plus user's input load resistance

I: 4-20mA

**Terminal Block Wiring - 7ME39406ML00 I/O Module (4-Channel)**

**FUS1010, 7ME35309 only**

(Refer to manual drawing 1010N-8MS2-7 (sheet 2 of 2))

Table A- 13 Input/Output Wiring (TB3) - 7ME39406ML00 I/O Module (4-Channel)

Pin#	Signal	Function	Description
1	lout 1+	Isolated Loop Supply	4-20mA proportional to spanned, selected variable (loop power). 4-20mA outputs also provide a fault indication by dropping to 2mA if assigned to flow rate and under fault conditions.
2	lout 1-	Isolated Loop Return	
3	lout 2+	Isolated Loop Supply	
4	lout 2-	Isolated Loop Return	
5	lout 3+	Isolated Loop Supply	
6	lout 3-	Isolated Loop Return	
7	lout 4+	Isolated Loop Supply	
8	lout 4-	Isolated Loop Return	

**Note**

Flow meter requires external power supply. Shunt as shown. Current is controlled within loop. 4-20mA inputs and outputs are isolated.

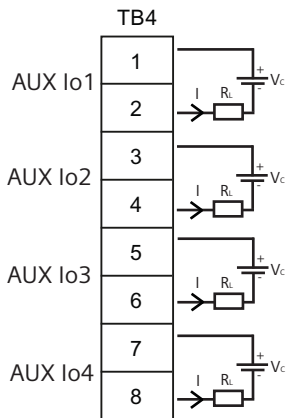

Vc = +30V (max) Loop Supply 1k ohm (max)

### Terminal Block Wiring - 7ME39404SB00 - Analog Input Module - 2 Channel/Dual Path

(Refer to manual drawing 1010N-5DS2-7)

These connection diagrams apply to the part numbers listed below.

Table A- 14 Connection Diagrams and Part Numbers

1010N-5DS2-7 Drawing	
FUS1010	7ME3530, 7ME3533
FUE1010	7ME3500
FUH1010	7ME3600, 7ME3603

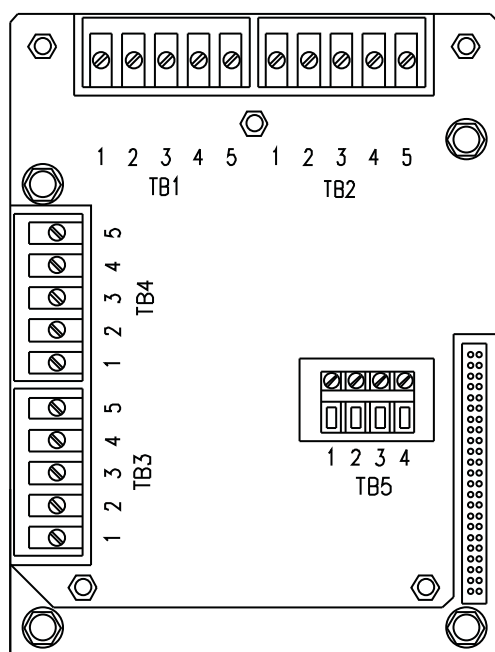

Figure A-4 7ME39404SB00 Analog Input Module

**Note**

Use 1012ECN series cables to connect between temperature sensor input wiring terminals TB1 through TB4 and 991T or 1011T series temperature sensors. Note Supply and Return temperature sensor designations when used with FUE1010 series energy flowmeter.

**Note**

Alternate color codes for certain 1012EC cables: white = orange / Green = Brown

Table A- 15 Input/Output Wiring TB1 7ME39404SB00 - Analog Input Module (2 Chan/Dual Path)

Pin	Color	Function	Description	Wiring/Cable
TB1-1	Black	RTD Current High	RTD Temperature measurement T1 or Channel 1 Ts (Supply Temperature)	AWG. 14 - 24 / 1000 Ft max w/o factory approval
TB1-2	White	RTD Voltage High		
TB1-3	Green	RTD Voltage Low		
TB1-4	Red	RTD Current Low		
TB1-5	Blue	Ground		

Table A- 16 Input/Output Wiring TB2 7ME39404SB00 - Analog Input Module (2 Chan/Dual Path)

Pin	Color	Function	Description	Wiring/Cable
TB2-1	Black	RTD Current High	RTD Temperature measurement T2 or Channel 1 Tr (Return Temperature)	AWG. 14 - 24 / 1000 Ft max w/o factory approval
TB2-2	White	RTD Voltage High		
TB2-3	Green	RTD Voltage Low		
TB2-4	Red	RTD Current Low		
TB2-5	Blue	Ground		

Table A- 17 Input/Output Wiring TB3 7ME39404SB00 - Analog Input Module (2 Chan/Dual Path)

Pin	Color	Function	Description	Wiring/Cable
TB3-1	Black	RTD Current High	RTD Temperature measurement T3 or Channel 2 Ts (Supply Temperature)	AWG. 14 - 24 / 1000 Ft max w/o factory approval
TB3-2	White	RTD Voltage High		
TB3-3	Green	RTD Voltage Low		
TB3-4	Red	RTD Current Low		
TB3-5	Blue	Ground		

Table A- 18 Input/Output Wiring TB4 7ME39404SB00 - Analog Input Module (2 Chan/Dual Path)

Pin	Color	Function	Description	Wiring/Cable
TB4-1	Black	RTD Current High	RTD Temperature measurement T4 or Channel 2 Tr (Return Temperature)	AWG. 14 - 24 / 1000 Ft max w/o factory approval
TB4-2	White	RTD Voltage High		
TB4-3	Green	RTD Voltage Low		
TB4-4	Red	RTD Current Low		
TB4-5	Blue	Ground		

Table A- 19 Input/Output Wiring TB5 7ME39404SB00 - Analog Input Module (2 Chan/Dual Path)

Pin	Function	Use	Description	Behavior	Load	Wiring/Cable
TB5-1	AUX. 1 IN	lin1 Input	Analog current input referenced to meter ground	4 to 20 mA	200 Ω	AWG. 14-24 / 100 ft. max. w/o factory approval
TB5-2	AUX. 1 COM	lin1 Common				
TB5-3	AUX. 2 IN	lin2 Input				
TB5-4	AUX. 2 COM	lin2 Common				

Net load is 335 ohms when safety barriers are used.

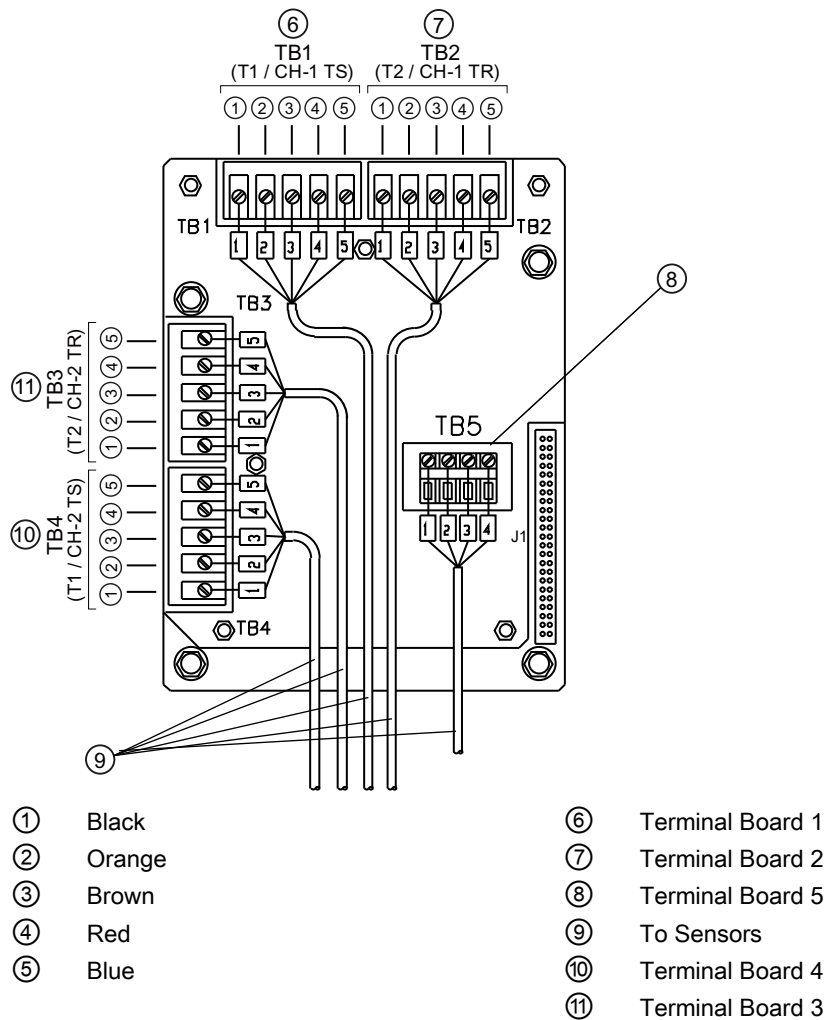

Figure A-5 Temperature Sensor Inputs

**Terminal Block Wiring - 7ME39400SA00 - Analog Input Module - Single Channel**

(Refer to manual drawing 1010N-5S2-7)

These connection diagrams apply to the part numbers listed below.

Table A- 20 Connection Diagrams and Part Numbers

1010N-5S2-7 Drawing	
FUS1010	7ME3530, 7ME3533
FUH1010	7ME3600, 7ME3603

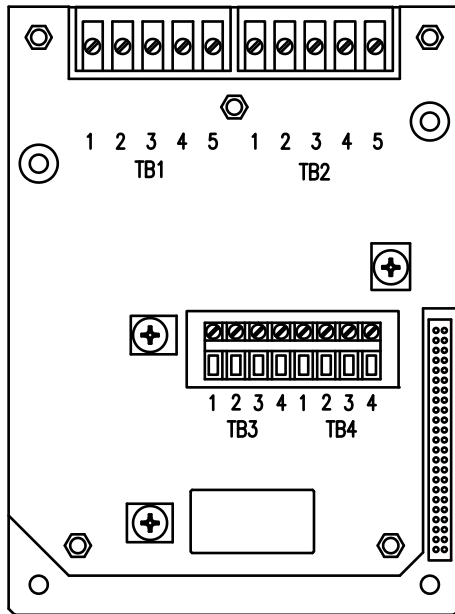

Figure A-6 7ME39400SA00 - Analog Input Module

Table A- 21 Input/Output Wiring TB1 7ME39400SA00 - Analog Input Module

Pin	Color	Function	Description	Wiring/Cable
TB1-1	Black	RTD Current High	RTD Temperature measurement T1 or Channel 1 Ts (Supply Temperature)	AWG. 14 - 24 / 1000 Ft max w/o factory approval
TB1-2	White	RTD Voltage High		
TB1-3	Green	RTD Voltage Low		
TB1-4	Red	RTD Current Low		
TB1-5	Blue	Ground		



Table A- 22 Input/Output Wiring TB2 7ME39400SA00 - Analog Input Module

Pin	Color	Function	Description	Wiring/Cable
TB2-1	Black	RTD Current High	RTD Temperature measurement T2 or Channel 1 Tr (Return Temperature)	AWG. 14 - 24 / 1000 Ft max w/o factory approval
TB2-2	White	RTD Voltage High		
TB2-3	Green	RTD Voltage Low		
TB2-4	Red	RTD Current Low		
TB2-5	Blue	Ground		

Table A- 23 Input/Output Wiring TB3 and TB4 7ME39400SA00 - Analog Input Module

Pin	TB3 Function	TB4 Function	Use	Description	Behaviour	Load	Wiring
1	AUX. 1 IN	AUX. 3 IN	lin1 Input	Analog current input referenced to meter ground.	4 to 20mA	200Ω	305 meters (1000 ft.) Max w/o factory approval
2	AUX. 1 COM	AUX. 3 COM	lin1 Common				
3	AUX. 2 IN	AUX. 4 IN	lin2 Input				
4	AUX. 2 COM	AUX. 4 COM	lin2 Common				

Net load is 335 ohms when safety barriers are used.

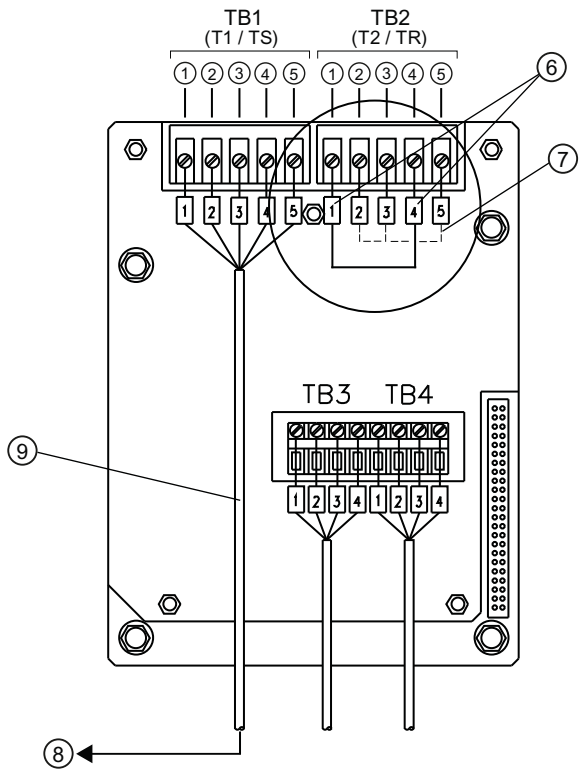

- ① Black
- ② Orange
- ③
- ④ Red
- ⑤ Blue
- ⑥ Short Terminals 1 and 4 (For FUE1010 - TB2 is used for another Temperature sensor.)
- ⑦ Ground Terminals 2 and 3 to Terminal 5
- ⑧ To Sensor
- ⑨ 7ME39600CR (992EC) Series Cable

## A.4 RS-232 Connection

The hardware and software requirements for programming the SITRANS F-1010 models require a PC connected to the RS-232 serial port. The serial interface cable includes 9-pin and 25-pin connectors to accommodate both types of IBM-compatible serial ports. A PC communication program such as Si-Ware (download program at: <http://s13.me/ns/cv>) or HyperTerminal (Windows 95/98/NT/2000/XP) serves as the data entry interface. These programs reproduce the menu screens that would appear on the system's graphic screen. Once the serial interface is established you can choose to program a graphic display system using a PC and a communications program. However, note that the serial interface cable is an option.

**Note**

You can use a DOS-based communications program also. Make sure that your PC is loading the ANSI.SYS driver via your Config.sys file. Set the program's RS-232 parameters to match those of the flow meter (see HyperTerminal example screen on the following pages).

**Note**

Many newer Laptop PCs are not equipped with serial ports and only have USB ports. These PCs will require a USB RS-232 adaptor that can be purchased commercially.

**The RS-232 Interface Cable**

The physical connection between the flow meter and your PC is accomplished using a serial interface cable, part number: 1015CPC-N. The schematic below shows the configuration of the cable. The wire ends for the flow meter termination are tinned for easy insertion into TB1 on the flow meter. Each wire is labeled to identify the correct terminal pin on TB1. In addition, both connectors have their CTS pin shorted to the RTS pin (pins 4 - 5 on 25-pin connector and pins 7 - 8 on 9-pin connector) and this eliminates the need for hardware "handshaking."

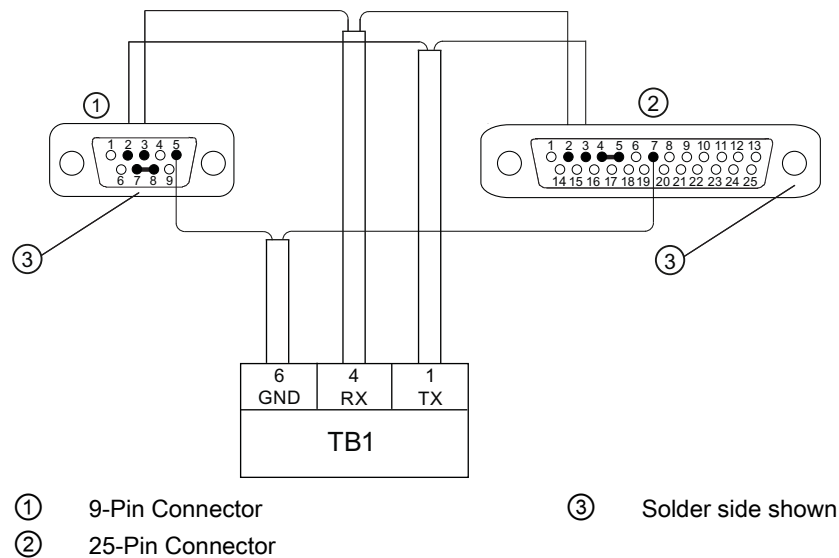

Figure A-7 1015CPC-N Serial Interface Cable

Due to the different SITRANS F 1010 flow meter configurations, there are 3 types of RS-232 communication cables employed. You can determine which cable is required for your model flow meter from the table below. Be sure you have the appropriate cable available for use.

For those who would prefer to make the cables themselves, the required parts (except for the RS-232 connector for the FUP1010WP flow meter types) should be available at most computer or electronics stores. You will find drawings of the terminations for these cables with the reference table below. It provides the signal names, PC termination and SITRANS F 1010 flow meter termination for each type of flow meter.

Flow meter Type	Cable Type	Siemens Part Number	Notes
Weatherproof Portable	DB-9F - Amphenol	CQO:1015CPC-WP	Except Energy Flow meter
FUE1010/FUP1010	DB-9F - DB-9F	CQO:1015CPC-P	Use for Energy WP
All NEMA 4X	DB-9F - 3 Wire	CQO:1015CPC-N	
NEMA 4X with Expanded I/O Module	DB-9F - DB-9F	CQO:1015CPC-P	For FUS1010 N with A1 option (1010N-7 module)
FUS1010 NEMA 7 Compact	DB-9F - 3 Wire	CQO:1015CPC-N	

Also, in most computer stores or online, you will be able to find or you may already have a serial "LapLink" cable or "Null Modem" cable. These cables can be used to communicate with the 1010P/DP systems.

If you purchased a 1010W model, you may have received the special connector used for the RS-232 terminal in a packet included with your 1010W. This will enable you to construct the appropriate cable for this flow meter type.

If you prefer to construct your own cable, the following conventions apply in the table:

- PC: Refers to an IBM compatible, DB-9 serial Com port.
- FUS1010 NEMA 4: Includes all models (N, DN, MN, FUE, EXCEPT those with "A1" option). Termination is made to the 1010N-2 I/O Data Module. Flow meter end of cable is un-terminated wire.
- FUS1010 NEMA 4 With "A1" Option: Flow meters that carry "A1" option have 1010N-7 module installed that houses a DB-9 connector for RS-232 communication.
- FUP1010 IP67: Includes all models (P/DP). Termination is made to the RS-232 port DB-9 connector. A DB-9 Female connector is needed to mate with the flow meter connector.
- FUP1010 WP: Includes all models (WP, WDP except energy meters). Termination is made to the RS-232 port on the connector panel. A special cable terminal is required and can be obtained from Siemens (Part #1015XWP).
- FUS1010X Compact: Includes all models (X, DX). Termination is made to the 1010X-8 I/O module Terminal TB2. Flow meter end of cable is un-terminated wire.

Signal Name	PC DB-9 Terminal	1010P Terminal	1010WP Terminal	1010N Terminal	1010X Terminal
Ground	Pin 5	Pin 5	Pin E	TB1-pin 6	TB2-pin 16
Tx	Pin 2	Pin 3	Pin C	TB1-pin 1	TB2-pin 11
Rx	Pin 3	Pin 2	Pin B	TB1-pin4	TB2-pin 14

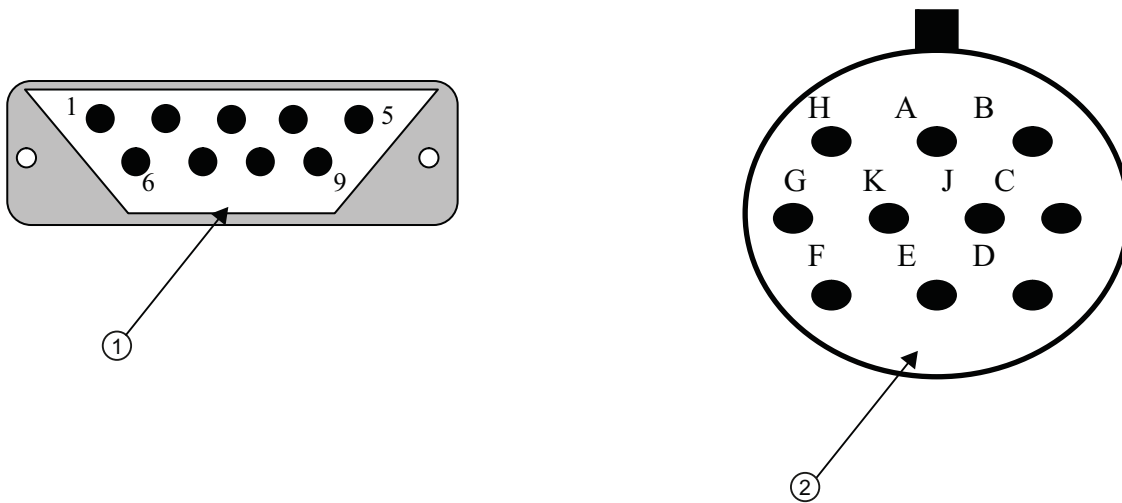

- ① PC DB-9 Connector  
1010P/990P Connector  
(Wiring Side View)
- ② 1010WP/WDP Connector  
(Wiring Side View)

### Communicating with SITRANS F 1010 Systems via the RS-232 Interface

The following sections assume that you are familiar with the basics of using Windows 95/98/NT/2000/XP based communications program. All PC computers provide at least one serial port using either a 9-pin or 25-pin D-type connector. The port designation can be either COM 1 or COM 2. Usually, when a computer includes two serial ports, COM 1 will be the 9-pin connector and COM 2 will be the 25-pin connector. However, port designations can vary from manufacturer to manufacturer, so you will have to positively identify the COM port you wish to use for the flow meter interface. Connect the cable between the flow meter and your PC using the 25-pin, 9-pin or USB to RS-232 adapter connector, depending upon the port's architecture.

### How to use the Windows HyperTerminal Program

---

#### Note

#### Si-Ware

If you want to use the Si-Ware program instead of HyperTerminal, download the program at [<http://s13.me/ns/cv>] and follow the setup instructions.

---

Windows provides a communication program called HyperTerminal, which is ideal for interfacing your computer with the flow meter. The following typical example explains how to set up HyperTerminal.

**Note**

Depending upon the Windows applications being used this setup procedure may vary.

1. From the Windows desktop, left-click on the [START] button.
2. Holding down the left mouse button, move the highlight up to [Programs], then across to [Accessories]. Slide the highlight down to [HyperTerminal], then release the left mouse button.
3. Within the HyperTerminal window, move the mouse pointer down to [Hyperterm.exe] and then double-click the left mouse button.
4. This selects the [Connection Description] dialog box. Enter a name for your connection (e.g., 1010N). You can optionally select an icon for this connection by clicking on one of the icons displayed in the scrolling frame at the bottom of the window. Click [OK].
5. This selects the [Phone Number] dialog box. Move the cursor to the arrow at the right of the [Connect Using] field. Left click on the arrow to expand the field and then move the highlight down to [Direct to Com 1 (or 2)] depending on the port connected to the interface cable. Click [OK] to select the [Com 1 (or 2) Properties] Dialog box. Set up your RS-232 parameters as shown in the example below. Left-click on the [OK] button.

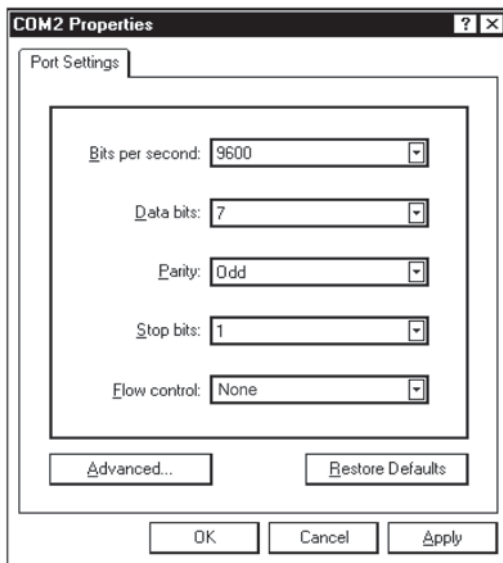

6. You will now see a blank terminal screen. Next left-click [File] on the top menu bar. Drag the highlight down to [Properties] and then left-click.

7. Left-click the [Settings] tab. Expand the [Emulation] box by left-clicking the <Down Arrow> on the right-hand side. Drag the highlight down to [VT-100] and then left-click to select it (as shown below).

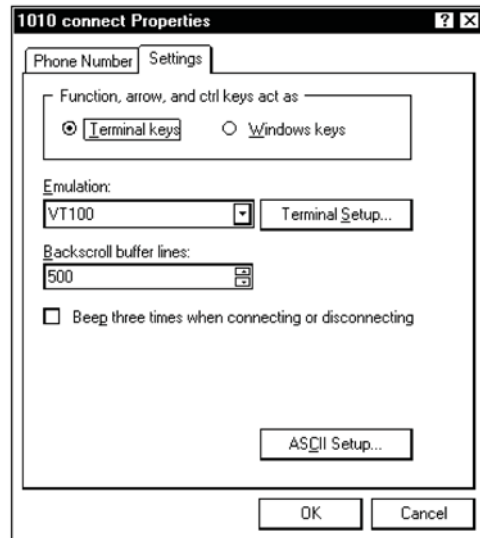

8. Next, left-click on the [ASCII Setup] button (see screen above). In the [ASCII Sending] dialog box, make sure that both [send line ends with line feeds] and [Echo Typed characters locally] are UNCHECKED. In the [ASCII Receiving] dialog box, left-click to place a check mark before the [Append line feeds to incoming line ends] dialog. When your screen looks like the example below, left-click the [OK] button.

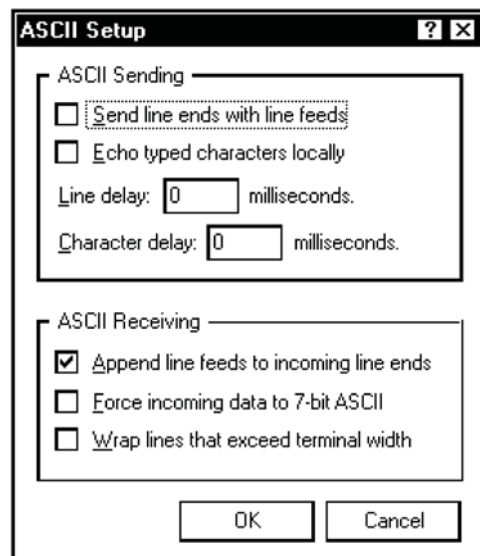

9. You are now ready to communicate with the 1010 flow meter. But first, save your settings by moving the mouse cursor to [File], sliding the cursor to [Save], then clicking [OK] on the Save dialog box.
10. The next time you want to use HyperTerminal:
- Click on Start.
  - Drag to Programs.

- Drag to Accessories. Drag to HyperTerminal, and click.
- Double-click the icon you selected for the connection.

---

**Note**

For easier access, create a shortcut to the connect icon from your desktop. Right-click on the icon to open its dialog box. Left-click on [Copy] or [Create a Short Cut] and then move the mouse cursor to a blank area on your desktop. Right-click to open dialog box and then left-click on [Paste] to place a shortcut to the connect icon on your desktop.

---

**Accessing the Installation Menu**

Once the parameters are set, HyperTerminal automatically initiates Command mode. You will see a blank screen.

1. Press <Enter> a few times until you see [? For Help] on the screen.
2. Type: ? (question mark) and then press <Enter> to see a list of the available commands.

Use the MENU command (type Menu and then press <Enter>) to access the top level of the Installation Menu. You will see a screen similar to the example below.

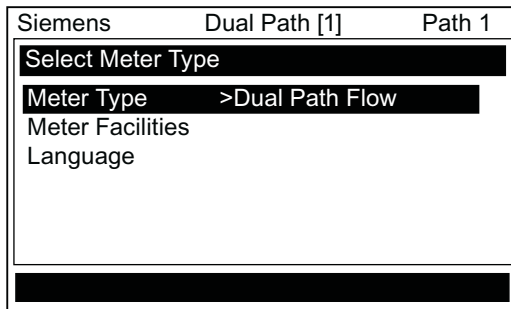

---

**Note**

To facilitate connecting through modems, the [Menu] command times out after three minutes of inactivity. To maintain a longer connection type: Menu 1000 and press <Enter>. The optional number is the amount in minutes that the connection will be maintained. Typing [Menu 1000] essentially keeps the interface active until you cancel it.

---



## Data Display Mode

After you complete the installation, you can toggle between Installation Menu mode to Data Display mode. This is the same as using the <MENU> key on the keypad (see manual). The PC keyboard equivalent to the <MENU> key is <CTRL> + <L>. Note that the RS-232 interface does not support graphics. Therefore, when you use HyperTerminal to view the data display screens, you will see the same data in alphanumeric form only (as shown below). You can still use the <Up Arrow> and <Down Arrow> to switch between available display screens.

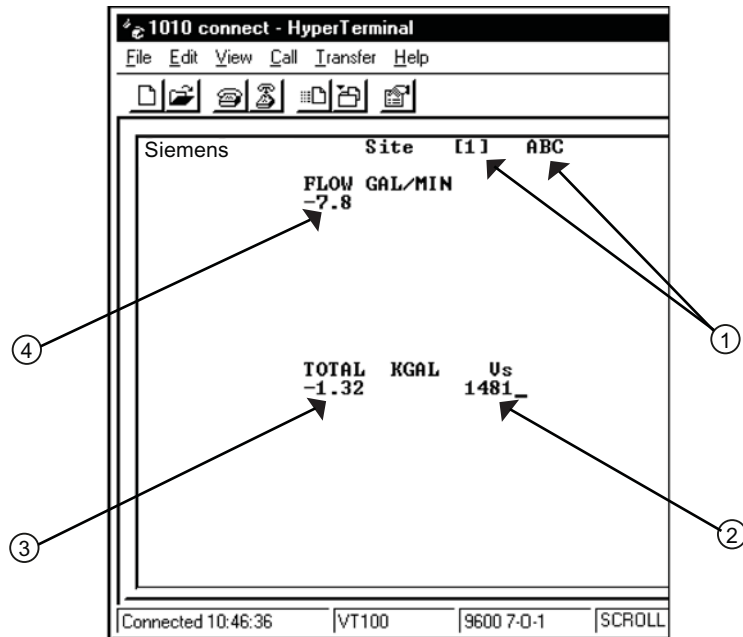

- ① Current active site setup name. The [1] indicates that the measurement channel is active.
- ② The current measured liquid sonic velocity.
- ③ The flow Total display.
- ④ The current flow reading and flow units.

### Navigating through the Installation Menu

After accessing the Installation Menu, you can begin to setup your flow meter according to the instructions in this manual. The chart below shows the PC keyboard equivalents to the keypad keys while you are in the menu.

SITRANS F 1010 Keypad	PC Keyboard	Description
<Up Arrow>	<Up Arrow>	Move up 1 menu cell (or Flow Display screen)
<Down Arrow>	<Down Arrow>	Move down 1 menu cell (or Flow Display screen)
<Right Arrow>	<Right Arrow>	Move right 1 menu cell (or Flow Display screen)
<Left Arrow>	<Left Arrow>	Move left 1 menu cell (or Flow Display screen)
<MENU>	^L (Ctrl L)	Toggle between Menu and Flow Display
<DATALOG>	^D (Ctrl D)	Generate Datalogger report
<CLR>	<Backspace> or <DEL>	Deselect list selection
<ALT+Up Arrow>	^U (Ctrl U)	Logger Display Page Advance
<+/-> (chg sign)	(bar, shift + backslash)	Change numeric sign. Can also type (-) key
<ENTER>	<Carriage Return>	Enter Key
Digits	Digits	Numerals zero through 9
/	/	Divide by
X	* (upper case 8)	Multiply by
+	+	Plus
-	-	Minus
=	=	Equals
.	.	Decimal Point

### Terminal Mode Menu Commands

In addition to Menu, the following commands (followed by the <Enter> key) can be used to control the flow meter while in Terminal Mode.

#### Note

The "n" refers to the flow meter Channel number. For a 2-Channel Arithmetic site (Ch1 + Ch2 or Ch1 – Ch2) the virtual Channel is number 3.

**Logger**

Invokes the download of all data stored in the Datalogger. Note that the Datalogger data is not erased from the flow meter memory when it is downloaded. It is recommended to capture this information into a file with a "csv" extension, which can be easily imported into MS Excel.

**SITE**

Invokes a full site download for a single channel or multi-path 1010 flow meter.

**SITE "n"**

Invokes a site download for channel "n", where "n" = the Channel # (1, 2, 3, 4, etc.).

**DP "n"**

Commands the flow meter to download the digitized receive signal data for Channel or Path "n".

**CLRTOT**

Clears the Totalizer for a single channel or multi-path 1010 flow meter.

**CLRTOT "n"**

Clears the Totalizer for Channel "n" of a multi-channel flow meter.

**Lf on**

Turns on the Line Feed at the end of any text string sent by the flow meter.

**Lf off**

Turns off the Line Feed at the end of any text string sent by the flow meter.

**?**

Provides a list of available Terminal Mode flow meter commands.

**Transferring information from a 1010 flow meter to the PC**

With HyperTerminal active:

1. Point to [Transfers], and click.
2. Select [Capture Text].
3. Select desired drive path or directory, enter a file name, and click the Start button.

4. Use the following conventions for data file names:
  - For site data or Wave shape data: filename.txt
  - For Datalogger data: filename.csv
5. On the PC type the proper command for the data desired (Logger, Site, or DP) and then press [Enter] key.
6. The data should begin streaming on the HyperTerminal screen.
7. Wait for EOT (End Of Transmission) to be displayed.
8. Close the file by pointing to Transfer, drag to Capture Text and click Stop button.

### Closing the Terminal or HyperTerminal Program

You may now close the Terminal program. The file(s) you have downloaded are now saved in the location you selected. You may now import the file you have saved into the appropriate program (i.e. MS Word for site data, or MS Excel for Datalogger or wave shape data for graphing or analysis).

The Datalogger contains data that has its fields separated by commas. By using the file extension ".csv" (comma separated values) suggested earlier, the data will import directly into MS Excel without any further modification. For the wave shape data, the fields are separated by spaces, therefore, it is best to save those files as .txt and then use the MS Excel Import Wizard to select "Space Delimiters" for importation of the data.

Site data is downloaded in plain text and can be imported directly into MS Word.

### Reset Procedure for Blind Systems

SITRANS F 1010 Blind systems allow you to perform a system reset via the RS-232 interface. The following instructions require the flow meter to be connected serially to a PC.

---

#### Note

Custom RS-232 settings for baud rate, parity and data bits may not be preserved. Therefore, be prepared to set your communications program back to the default (9600, Odd, 7) settings.

---

### To Clear Active Memory using the RS-232 Interface

1. Turn off power (if it is currently on). Turn power on. As soon as you apply power, immediately type the @ character three times. The prompt: **[Clr Active Memory? No]** appears at the top of the screen.
2. Press the <Right Arrow> and then the <Down Arrow> to switch the option list to: **[Clr Active Memory? Yes]** Press <ENTER> to clear all Active Site Data (but not saved site setups).
3. To restore operation, press <MENU> to access the Installation Menu. Create a new site setup or recall a stored site setup. Re-select any Meter Facilities items (e.g., RS-232 setup parameters).

## To Clear All Saved Data using the RS-232 Interface

<p><b>NOTICE</b></p> <p><b>Loss of RAM Data</b></p> <p>Before proceeding further it is essential to understand that this function eliminates ALL data stored in RAM. This means that all saved site setups including the site data of a flow-calibrated site will be erased! In addition, the entire Datalogger file plus any custom factory or user-created pipe or sensor tables will be eliminated.</p> <p>The impact of this is such that we strongly recommend that you consult Technical Services before continuing with this procedure. Be aware that you will have to create a new Site Setup, re-enter all site specific parameters including pipe or sensor tables, plus all desired Meter Facilities menu entries.</p>
---

1. Turn off power (if it is currently on).
2. Turn the power on. As soon as you apply power, type the @ character three times.
  - The prompt: **[Clr Active Memory?]** appears at the top of the screen. Press the <Down Arrow>.

---

### Note

Note that the prompt switches to **[Clr Saved Data? No]**.

---

3. Press the <Right Arrow> and then the <Down Arrow> to switch the option list to: **[Clr Saved Data? Yes]**.
4. Press <ENTER> to clear all Saved Site Data, Datalogger Data, user created Pipe Data and Sensor Data.
5. To restore operation, press <MENU> to access the Installation Menu. Create a new site setup or recall a stored site setup. Reselect any Meter Facilities items (e.g., RS-232 setup parameters).

## A.5 Flowrate Calibration and Calibration Tables

### Flowrate Calibration Methods

SITRANS F 1010 equipment provides three ways to condition the calibration performance of its flowrate output: Intrinsic (factory set), Kc, and Calibration Tables 1 through 3. Access to these calibration options is found in the [Calibrate Flowrate] menu cell and the three [Calib. Table] menu cells of the [Span/Set/Cal] menu.

### Intrinsic

When selected, the flow meter uses no slope adjustment at all. Output data is still zeroed and corrected for Reynolds number, but no slope adjustment is imposed on the flow meter's flow register.

Some applications may require an output adjustment to match an official external reference. The [Calibrate Flowrate] menu allows you to select a calibration mode. The right-hand column shows the active calibration mode. You can select Intrinsic (factory) and Kc (Slope Correction) Calibration. Selecting either of the external calibration modes will not eliminate the Intrinsic (factory) calibration. You can use this menu cell to switch between Intrinsic and Kc at any time.

### Kc Calibration

For most applications, the measured flow range produces a linear meter response. Therefore, the Kc (slope correction) calibration is the preferred method since it only requires a single correction factor for all the flow rates encountered.

---

#### Note

Changing the calibration can cause profound changes in flow meter operating characteristics. Use only the most respected flow standard to obtain a correction factor. The percentage entered must provide an accurate and consistent shift across the entire flow range anticipated for the application.

---

### Kc Factor

To obtain the Kc factor, compare flow total data taken simultaneously from the flow meter and a reference meter whose accuracy meets the required standard. Allow both meters to accumulate flow total data long enough to average out any differences due to flow fluctuation between the two meter locations. Compare outputs of the two totalizers to determine percentage increase (+) or decrease (-) that is necessary to produce the best average correlation between the flow meter and the reference standard.

### Selecting the Kc Factor

When the [Kc] menu cell is selected, the flow meter imposes this percentage slope adjustment of its rate output. Output data is zeroed and corrected for the Reynolds number (flow profile compensated), however, a percent change in the rate output is imposed based on the data entered in this cell. The number entered by the user is evaluated into a slope correction factor by dividing it by 100 and algebraically adding it to 1. The resulting factor is used as a multiplier on the rate register of the instrument. Thus an entry of -3% will multiply the rate register by 0.97, for example.

#### To calculate Kc:

$$Kc = \left[ \frac{\text{Actual Rate}}{\text{Indicated Rate}} - 1 \right] \times 100$$

**To enter the Kc Factor**

1. To enable numeric entry press <Right Arrow>.
2. Use the numeric keys to type the required Kc (as calculated above). Note that the Kc value can be negative or positive. Enter the - or + sign first, then type in the calibrated value.
3. To store the data press <ENTER>. Note that Kc now appears in the right-hand column of the [Calibrate Flow Rate] menu cell with its new value. Also note that this Kc value can be viewed on the site printout.

**Calibration Tables 1 through 3**

SITRANS F 1010 instruments offer a unique methodology by which a particular flow response of an instrument may be linearized or optimized by tabulating the results of a series of calibration exercises or collected batch data points. Basically, the flow meter allows the user to select any of a wide variety of system variables (flow rate, pressure, viscosity, etc.) as a pointer into a table of calibration factors (up to 32). As the system variable is updated, the value of the table's output factors (or positive and negative flow) is re-evaluated and used as a modifier for the current rate register. Note that the flow register is still zeroed and Reynolds number compensated normally and these slope corrections are in addition to these fundamentals.

---

**Note**

Kc is still active when this method is being used.

---

**To install a Calibration table:**

1. The user selects a system variable that appears to correlate strongly with calibration shifts observed.
2. A table of values is formed comprised of the values that this index could assume over the range of system operation. Remember, the tables created do not extrapolate beyond their end points, they "clip."
3. A calibration factor, a number usually close to 1.00, is entered as a positive and a negative flow rate correction factor (termed PosFlow Corr and NegFlow Corr) for each of the desired index points.

The table may contain up to 32 pairs of these slope correction factors. Note that the Kc factor, unlike these slope correction factors, is entered as a signed percent change in rate, while these factors are simply rate multipliers. As points are entered, the point editor will provide list access to the already entered points plus access to the [New Point] menu cell, used to add a new point. The table may be created in its entirety and then activated by selecting [Yes] in the [Table Active] menu cell. The entire table may be cleared by selecting [Yes] in the [Clear Table] menu cell.

---

**Note**

Careless use of the calibration tables can have a detrimental impact on the measurement performance of the flow meter.

---

---

**Note**

Take precautions before enabling these calibration tables. Although it is unlikely that all three tables would ever be employed in a real installation, three tables are offered for maximum user flexibility. Since the tables can be disabled without being destroyed, 2 or 3 optimization strategies may be tested by this means in order to determine which approach is most effective.

---



## Appendix

### B.1 Installation/Outline Drawings

#### Installation/Outline Drawings

The following are the installation and outline drawings for the SITRANS FUE1010 IP65 NEMA 4X flow meter.

1010NS2-7 Rev D - Installation Drawing, 1010 Series Flow Computer, Agency Approved

1010N-7-7 Rev 08 - Installation Wiring, Expanded I/O Module

1010N-2-7 Rev 05 - Installation Wiring, I/O Module

1010N-5S2-7 Rev D - Installation Drawing, Analog Input Module

1010N-5DS2-7 Rev 06 - Installation Drawing, Analog Input Module

1010N-8MS2-7 Rev 03 - Installation Wiring, I/O Module

1010-304 Rev 14 - Connection Diagram for Hazardous Area Use, Agency Approved, 1010NS2/1010MNS2 Series Flow Computer

1010WX-S2-7 Rev A - Installation Drawing, 1010 Series Single/Dual Channel Flow Computer, Agency Approved

1010MNS2-7 Rev C - Installation Drawing, 1010 Series Multi-Channel Flow Computer, Agency Approved

1010MWX-S2-7 Rev A - Installation Drawing, 1010 Series Multi-Channel Flow Computer, Agency Approved

1010-443 Rev 05 - Connection Diagram for Hazardous Area Use, Agency Approved, 1010WX-S2 Series Flow Computer

1010NS9-7 Rev A - Installation Drawing, 1010 Series Flow Computer, Agency Approved

1010MNS9-7 Rev A - Installation Drawing, 1010 Series Multi-Channel Flow Computer, Agency Approved

1010-389 Rev 05 - Connection Diagram, Agency Approved for Hazardous Area Use, 1010NS9/1010MNS9 Series Flow Computer

1010-391 Rev C - Connection Diagram, Agency Approved for Zone 2 Connections, 1010NS9 Flow Computer System

1011NS2-7 Rev D - Installation Guide, Connection Diagram Selection, Agency Approved, 1011N Series Transducers

- 1011NS9-7 Rev C1 - Installation Guide, Connection Diagram Selection, Agency Approved, 1011N Series Transducers
- 1011NFPS-7 Rev B - Installation Drawing, 1011NPFS Series dedicated Plastic Body Transducer
- 1011HNS2-7 Rev D - Installation Guide, Connection Diagram Selection, Agency Approved, 1011HN Series Transducers
- 1011HNS9-7 Rev C1 - Installation Guide, Connection Diagram Selection, Agency Approved, 1011HN Series Transducers
- 1011HNFS-7 Rev 02 - Installation, 1011HNFS Series Dedicated Plastic Body Transducer
  
- 1012F-DB-7 Rev B - Installation Drawing, Dual Path Transducer Set w/Mounting Frames
- 1012MS-8 Rev F - Installation/Outline, Adjustable Mounting Strap
- 1012TN-7 Rev A - Installation Drawing, 1010 Series Transducers and Mounting Tracks
- 1012TNH-7 Rev A - Installation Drawing, 1010 Series Transducer and Mounting Tracks
  
- 991TS2-7 Rev 03- Installation Drawing, Temp. Sensor, Dedicated NEMA 4, Pipe O.D. 1 1/4" - 48" (32-1220mm)
- 991TDS2-7 Rev 03 - Installation Drawing, 991TD Temperature Sensor, Submersible, Agency Approved
  
- 990TDMVH-7B Rev F - Installation Drawing, 990 Series Transducer, Direct Mode, Very High Temp.
- 990TRMVH-7B Rev F - Installation Drawing, 990 Series Transducer, Reflect Mode, Very High Temp.
- 990TDMVH-7A Rev B - Installation Drawing, 990 Series Transducer and Tracks, Very High Temp., Direct Mode
- 990TRMVH-7A Rev C - Installation Drawing, 990 Series Transducer and Tracks, Very High Temp., Reflect Mode
  
- 991TN-7 Rev G - Installation Drawing, Temperature Sensor, NEMA 4
- 991TN-7A Rev D - Installation Drawing, 990 Series, Temperature Sensor, NEMA 4
- 991TWS2-8 Rev 02- Installation/Outline Dimensions, Insert Temperature Sensor
- 991TDS2-7 Rev B - Installation Drawing, 991TD Temperature Sensor, Submersible, Agency Approved
- 191N1S-7 Rev C - Installation Drawing, 191N1S Transducer, NEMA 4
- 191N1H-7 Rev B - Installation Drawing, 191N1H Transducer, Hi Temp, NEMA 4



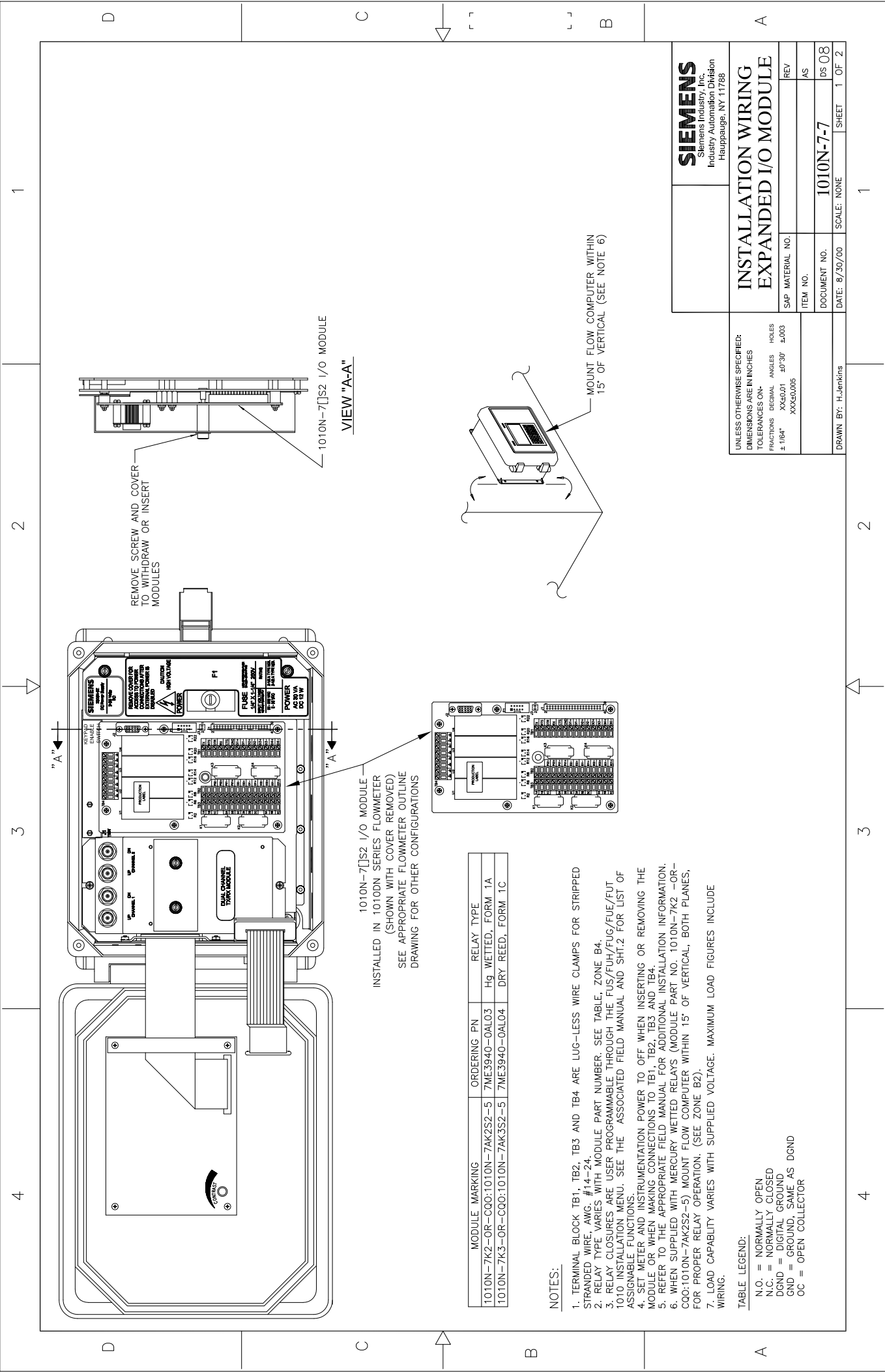

REMOVE SCREW AND COVER TO WITHDRAW OR INSERT MODULES

1010N-7[S2] I/O MODULE

VIEW "A-A"

1010N-7[S2] I/O MODULE  
 INSTALLED IN 1010DN SERIES FLOWMETER  
 (SHOWN WITH COVER REMOVED)  
 SEE APPROPRIATE FLOWMETER OUTLINE  
 DRAWING FOR OTHER CONFIGURATIONS

MOUNT FLOW COMPUTER WITHIN 15° OF VERTICAL (SEE NOTE 6)

MODULE MARKING	ORDERING PN	RELAY TYPE
1010N-7K2-OR-CQ0:1010N-7AK2S2-5	7ME3940-0AL03	Hg WETTED, FORM 1A
1010N-7K3-OR-CQ0:1010N-7AK3S2-5	7ME3940-0AL04	DRY REED, FORM 1C

NOTES:

1. TERMINAL BLOCK TB1, TB2, TB3 AND TB4 ARE LUG-LESS WIRE CLAMPS FOR STRIPPED STRANDED WIRE, AWG. #14-24.
2. RELAY TYPE VARIES WITH MODULE PART NUMBER. SEE TABLE B4.
3. RELAY CLOSURES ARE USER PROGRAMMABLE THROUGH THE FUS/FUH/FUG/FUT/FUI/T INSTALLATION MENU. SEE THE ASSOCIATED FIELD MANUAL AND SHT.2 FOR LIST OF ASSIGNABLE FUNCTIONS.
4. SET METER AND INSTRUMENTATION POWER TO OFF WHEN INSERTING OR REMOVING THE MODULE OR WHEN MAKING CONNECTIONS TO TB1, TB2, TB3 AND TB4.
5. REFER TO THE APPROPRIATE FIELD MANUAL FOR ADDITIONAL INSTALLATION INFORMATION.
6. WHEN SUPPLIED WITH MERCURY WETTED RELAYS (MODULE PART NO. 1010N-7K2 -OR- CQ0:1010N-7AK2S2-5) MOUNT FLOW COMPUTER WITHIN 15° OF VERTICAL, BOTH PLANES, FOR PROPER RELAY OPERATION. (SEE ZONE B2).
7. LOAD CAPABILITY VARIES WITH SUPPLIED VOLTAGE. MAXIMUM LOAD FIGURES INCLUDE WIRING.

TABLE LEGEND:

- N.O. = NORMALLY OPEN
- N.C. = NORMALLY CLOSED
- DGND = DIGITAL GROUND
- GND = GROUND, SAME AS DGND
- OC = OPEN COLLECTOR

**SIEMENS**  
 Siemens Industry, Inc.  
 Industry Automation Division  
 Hauppauge, NY 11788

**INSTALLATION WIRING  
 EXPANDED I/O MODULE**

SAP MATERIAL NO.	REV
ITEM NO.	AS
DOCUMENT NO.	1010N-7-7
DATE: 8/30/00	SCALE: NONE
SHEET 1 OF 2	

UNLESS OTHERWISE SPECIFIED:  
 DIMENSIONS ARE IN INCHES  
 TOLERANCES ON-  
 FRACTIONS DECIMAL ANGLES HOLES  
 ± 1/64" XX±0.01 ±0.30 ±.003  
 XXX±0.005

DRAWN BY: H.Jenkins



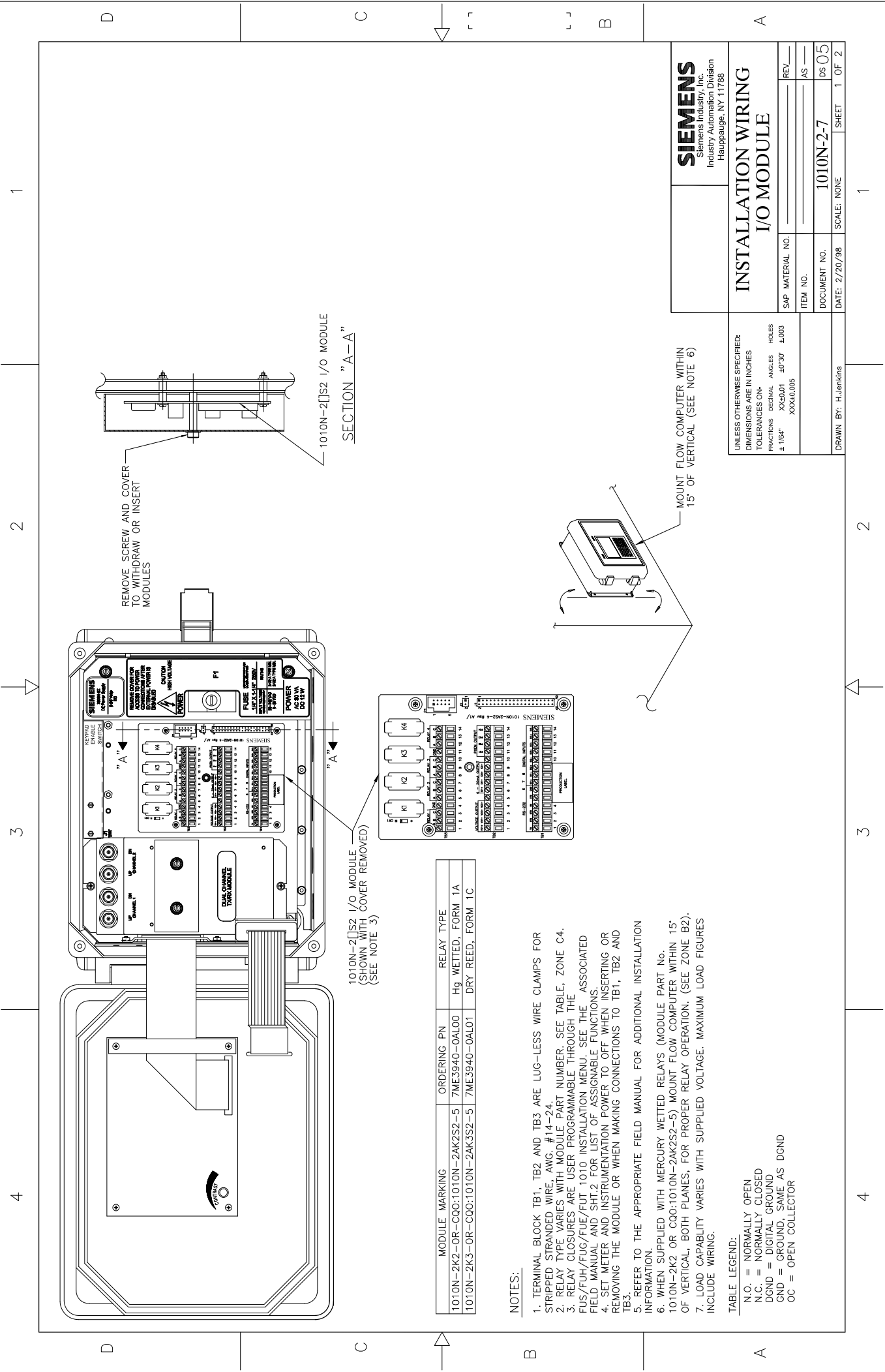

REMOVE SCREW AND COVER TO WITHDRAW OR INSERT MODULES

1010N-2 I/O MODULE SECTION "A-A"

1010N-2 I/O MODULE (SHOWN WITH COVER REMOVED) (SEE NOTE 3)

MOUNT FLOW COMPUTER WITHIN 15" OF VERTICAL (SEE NOTE 6)

MODULE MARKING	ORDERING PN	RELAY TYPE
1010N-2K2-OR-C00:1010N-2AK2S2-5	7ME3940-0AL00	Hg WETTED, FORM 1A
1010N-2K3-OR-C00:1010N-2AK3S2-5	7ME3940-0AL01	DRY REED, FORM 1C

**NOTES:**

1. TERMINAL BLOCK TB1, TB2 AND TB3 ARE LUG-LESS WIRE CLAMPS FOR STRIPPED STRANDED WIRE, AWG. #14-24.
2. RELAY TYPE VARIES WITH MODULE PART NUMBER. SEE TABLE, ZONE C4.
3. RELAY CLOSURES ARE USER PROGRAMMABLE THROUGH THE FUS/FUH/FUG/FUE/FUT 1010 INSTALLATION MENU. SEE THE ASSOCIATED FIELD MANUAL AND SHT-2 FOR LIST OF ASSIGNABLE FUNCTIONS.
4. SET METER AND INSTRUMENTATION POWER TO OFF WHEN INSERTING OR REMOVING THE MODULE OR WHEN MAKING CONNECTIONS TO TB1, TB2 AND TB3.
5. REFER TO THE APPROPRIATE FIELD MANUAL FOR ADDITIONAL INSTALLATION INFORMATION.
6. WHEN SUPPLIED WITH MERCURY WETTED RELAYS (MODULE PART No. 1010N-2K2 OR C00:1010N-2AK2S2-5) MOUNT FLOW COMPUTER WITHIN 15" OF VERTICAL, BOTH PLANES. FOR PROPER RELAY OPERATION. (SEE ZONE B2).
7. LOAD CAPABILITY VARIES WITH SUPPLIED VOLTAGE. MAXIMUM LOAD FIGURES INCLUDE WIRING.

**TABLE LEGEND:**

- N.O. = NORMALLY OPEN
- N.C. = NORMALLY CLOSED
- DGND = DIGITAL GROUND
- GND = GROUND, SAME AS DGND
- OC = OPEN COLLECTOR

**SIEMENS**  
Siemens Industry, Inc.  
Industry Automation Division  
Hempstead, NY 11788

**INSTALLATION WIRING I/O MODULE**

SAP MATERIAL NO.	REV.
ITEM NO.	AS
DOCUMENT NO.	1010N-2-7
DATE: 2/20/98	SCALE: NONE
SHEET 1 OF 2	

UNLESS OTHERWISE SPECIFIED:  
DIMENSIONS ARE IN INCHES  
TOLERANCES ON-  
FRACTIONS DECIMAL ANGLES HOLES  
± 1/64" XX.001 ±0.30 ±.003  
XXX.005

DRAWN BY: H.Jenkins

TERMINAL BLOCK WIRING CONNECTIONS

METER PMS AND OPERATING SYSTEMS
7ME350\*g SITRANS FUE1010 OP SYSTEMS: 5N01-->5N04
7ME353\*g SITRANS FUE1010 OP SYSTEMS: 5N01-->5N04
7ME360\*2 SITRANS FUE1010 OP SYSTEMS: 5B01-->5B02

METER INSTALLATION CONFIGURATION
1x TRANSMIT
2 R/S REQUEST TO SEND
3 DIR DATA TERMINAL READY
4 DIR CLEAR TO SEND
5 CS CLEAR TO SEND
6 GND GROUND [GND]
7 D1+ DIGITAL INPUT 1
8 D1- DIGITAL RETURN [GND]
9 D2+ DIGITAL INPUT 2
10 D2- DIGITAL RETURN [GND]
11 D3+ DIGITAL INPUT 3
12 D3- DIGITAL RETURN [GND]
13 D4+ DIGITAL INPUT 4
14 D4- DIGITAL RETURN [GND]

METER INSTALLATION CONFIGURATION
1x TRANSMIT
2 R/S REQUEST TO SEND
3 DIR DATA TERMINAL READY
4 DIR CLEAR TO SEND
5 CS CLEAR TO SEND
6 GND GROUND [GND]
7 D1+ DIGITAL INPUT 1
8 D1- DIGITAL RETURN [GND]
9 D2+ DIGITAL INPUT 2
10 D2- DIGITAL RETURN [GND]
11 D3+ DIGITAL INPUT 3
12 D3- DIGITAL RETURN [GND]
13 D4+ DIGITAL INPUT 4
14 D4- DIGITAL RETURN [GND]

METER INSTALLATION CONFIGURATION
1x TRANSMIT
2 R/S REQUEST TO SEND
3 DIR DATA TERMINAL READY
4 DIR CLEAR TO SEND
5 CS CLEAR TO SEND
6 GND GROUND [GND]
7 D1+ DIGITAL INPUT 1
8 D1- DIGITAL RETURN [GND]
9 D2+ DIGITAL INPUT 2
10 D2- DIGITAL RETURN [GND]
11 D3+ DIGITAL INPUT 3
12 D3- DIGITAL RETURN [GND]
13 D4+ DIGITAL INPUT 4
14 D4- DIGITAL RETURN [GND]

Table with columns: PIN #, SIGNAL, DEFINITION, DESCRIPTION, SINGLE CHANNEL FUNCTION, DUAL CHANNEL FUNCTION, DUAL PATH FUNCTION, DUAL PATH ONLY FUNCTION, LOAD, WIRING, CABLE LENGTH, NOTES. Includes rows for TB1 (DIAGNOSTIC PORT), TB2 (METER INSTALLATION CONFIGURATION), and TB3 (METER INSTALLATION CONFIGURATION).

Table with columns: PIN #, SIGNAL, DEFINITION, DESCRIPTION, SINGLE CHANNEL FUNCTION, DUAL CHANNEL FUNCTION, DUAL PATH FUNCTION, DUAL PATH ONLY FUNCTION, LOAD, WIRING, CABLE LENGTH, NOTES. Includes rows for TB3 (METER INSTALLATION CONFIGURATION).

Table with columns: PIN #, SIGNAL, DEFINITION, DESCRIPTION, SINGLE CHANNEL FUNCTION, DUAL CHANNEL FUNCTION, DUAL PATH FUNCTION, DUAL PATH ONLY FUNCTION, LOAD, WIRING, CABLE LENGTH, NOTES. Includes rows for TB3 (METER INSTALLATION CONFIGURATION).

Table with columns: PIN #, SIGNAL, DEFINITION, DESCRIPTION, SINGLE CHANNEL FUNCTION, DUAL CHANNEL FUNCTION, DUAL PATH FUNCTION, DUAL PATH ONLY FUNCTION, LOAD, WIRING, CABLE LENGTH, NOTES. Includes rows for TB3 (METER INSTALLATION CONFIGURATION).

Table with columns: PIN #, SIGNAL, DEFINITION, DESCRIPTION, SINGLE CHANNEL FUNCTION, DUAL CHANNEL FUNCTION, DUAL PATH FUNCTION, DUAL PATH ONLY FUNCTION, LOAD, WIRING, CABLE LENGTH, NOTES. Includes rows for TB3 (METER INSTALLATION CONFIGURATION).

Table with columns: PIN #, SIGNAL, DEFINITION, DESCRIPTION, SINGLE CHANNEL FUNCTION, DUAL CHANNEL FUNCTION, DUAL PATH FUNCTION, DUAL PATH ONLY FUNCTION, LOAD, WIRING, CABLE LENGTH, NOTES. Includes rows for TB3 (METER INSTALLATION CONFIGURATION).

SIEMENS
Siemens Industry, Inc.
Industry Automation Division
Hauppauge, NY 11788

INSTALLATION WIRING I/O MODULE

Table with columns: SAP MATERIAL NO., ITEM NO., DOCUMENT NO., DATE: 2/20/98, SCALE: NONE, SHEET 2 OF 2.

UNLESS OTHERWISE SPECIFIED:
DIMENSIONS ARE IN INCHES;
TOLERANCES ON:
FRACTIONS DECIMAL ANGLES HOLES
±.104" XXX.001 ±0°30' ±.003
XXX.0005

1010N-2-7

DRAWN BY: H.Jenkins

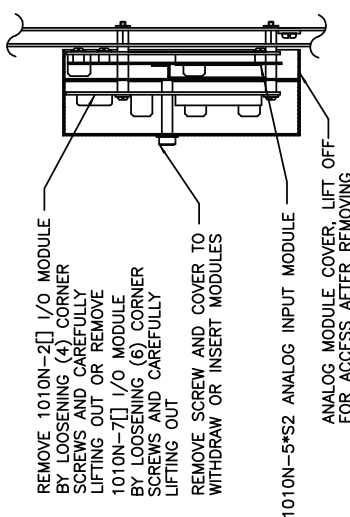

SECTION "A-A"

REMOVE 1010N-2 I/O MODULE BY LOOSENING (4) CORNER SCREWS AND CAREFULLY LIFTING OUT OR REMOVE 1010N-7 I/O MODULE BY LOOSENING (6) CORNER SCREWS AND CAREFULLY LIFTING OUT.  
REMOVE SCREW AND COVER TO WITHDRAW OR INSERT MODULES.

1010N-5\*S2 ANALOG INPUT MODULE  
ANALOG MODULE COVER, LIFT OFF FOR ACCESS AFTER REMOVING 1010N-2 I/O MODULE OR 1010N-7 I/O MODULE

**TB1 WIRING**

PN	COLOR	FUNCTION SEE NOTE 4	DESCRIPTION	WIRING	CABLE LENGTH	NOTES
1	BLACK	RTD CURRENT HIGH	RTD TEMPERATURE MEASUREMENT OF RTD TEMP. REFERENCE CO-1012EC CABLE	AWG.14-24	1000 FT. MAX.	SEE NOTE 3
2	WHITE	RTD VOLTAGE HIGH				
3	GREEN	RTD VOLTAGE LOW				
4	RED	RTD CURRENT LOW				
5	BLUE	GROUND				

**TB2 WIRING**

PN	COLOR	FUNCTION SEE NOTE 4	DESCRIPTION	WIRING	CABLE LENGTH	NOTES
1	BLACK	RTD CURRENT HIGH	RTD TEMPERATURE MEASUREMENT CHANNEL 2, T2 OR SUPPLY TEMP.	AWG.14-24	1000 FT. MAX.	SEE NOTE 3
2	WHITE	RTD VOLTAGE HIGH				
3	GREEN	RTD VOLTAGE LOW				
4	RED	RTD CURRENT LOW				
5	BLUE	GROUND				

**TB3 WIRING**

PN	FUNCTION SEE NOTE 4	USE	DESCRIPTION	BEHAVIOR	LOAD	WIRING	CABLE LENGTH	NOTES
1	AUX.1 IN	ANALOG CURRENT INPUT REFERENCED TO METER GROUND		4 TO 20 mA	2000	AWG.14-24	1000 FT. MAX.	SEE NOTES 3, 5
2	AUX.2 IN	IN2 INPUT						
3	AUX.2 COM	IN2 COMMON						
4	AUX.2 COM	IN2 COMMON						

**TB4 WIRING**

PN	FUNCTION SEE NOTE 4	USE	DESCRIPTION	BEHAVIOR	LOAD	WIRING	CABLE LENGTH	NOTES
1	AUX.3 IN	ANALOG CURRENT INPUT REFERENCED TO METER GROUND		4 TO 20 mA	2000	AWG.14-24	1000 FT. MAX.	SEE NOTES 3, 5
2	AUX.3 COM	IN3 COMMON						
3	AUX.4 IN	IN4 INPUT						
4	AUX.4 COM	IN4 COMMON						

1010N-5\*S2 ANALOG INPUT MODULE (SHOWN WITH SCREW, COVER AND I/O MODULE 1010N-2 REMOVED)

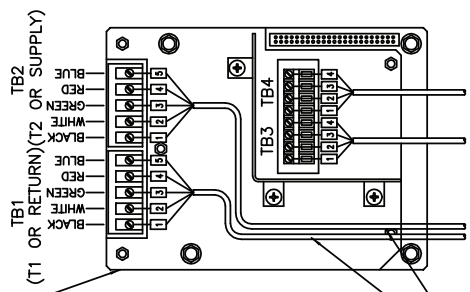

1012EC SERIES CABLES

ALTERNATE COLOR CODE FOR CERTAIN 1012EC CABLES:  
WHITE = ORANGE  
GREEN = BROWN

CONTROLLED DRAWING  
CHANGES TO THIS DRAWING REQUIRE RELEVANT AGENCY APPROVAL

**NOTES:**

1. TERMINAL BLOCK TB1, TB2, TB3 AND TB4 ARE LUG-LESS WIRE CLAMP TYPE, PROVIDING RELIABLE CONNECTION TO STRIPPED STRANDED WIRE, AWG. #14-24.
2. SET METER AND INSTRUMENTATION POWER TO OFF WHEN INSERTING OR REMOVING THE MODULE OR WHEN MAKING CONNECTIONS TO TB1, TB2, TB3 AND TB4.
3. REFER TO THE 1010 FIELD MANUAL FOR ADDITIONAL INSTALLATION INFORMATION.
4. USE 1012ECN SERIES CABLES TO CONNECT BETWEEN TEMPERATURE SENSOR INPUT WIRING TERMINALS TB1 AND TB2 AND 991T OR 1011T SERIES TEMPERATURE SENSORS. NOTE SUPPLY AND RETURN TEMPERATURE SENSOR DESIGNATIONS WHEN USED WITH A 1010E SERIES ENERGY FLOW COMPUTER.
5. NET LOAD IS 335 OHMS WHEN SAFETY BARRIERS ARE USED.

DO NOT SCALE THIS DRAWING  
UNLESS OTHERWISE SPECIFIED:  
DIMENSIONS ARE IN INCHES (MM)  
TOLERANCES ON INCHES  
± .1  
(MM)  
± .2

CONTRACT NO. \_\_\_\_\_  
 DR. H.J. DATE 7/18/98  
 CHK. \_\_\_\_\_ DATE \_\_\_\_\_  
 ENG. \_\_\_\_\_ DATE \_\_\_\_\_  
 APPD. \_\_\_\_\_ DATE \_\_\_\_\_  
 CERTIFIED \_\_\_\_\_  
 DATE \_\_\_\_\_

**SIEMENS**  
 Siemens Energy & Automation, Inc.  
 Process Instrumentation Business Unit  
 CoC Ultrasonic Flow - Hauppauge, Long Island, NY 11788

**INSTALLATION DRAWING**  
**ANALOG INPUT MODULE**

SIZE CODE IDENT NO. **C 21614** 1010N-5S2-7 REV. **D**  
 SCALE: NONE WT. SHEET 1 OF 1



1  
2  
3  
4

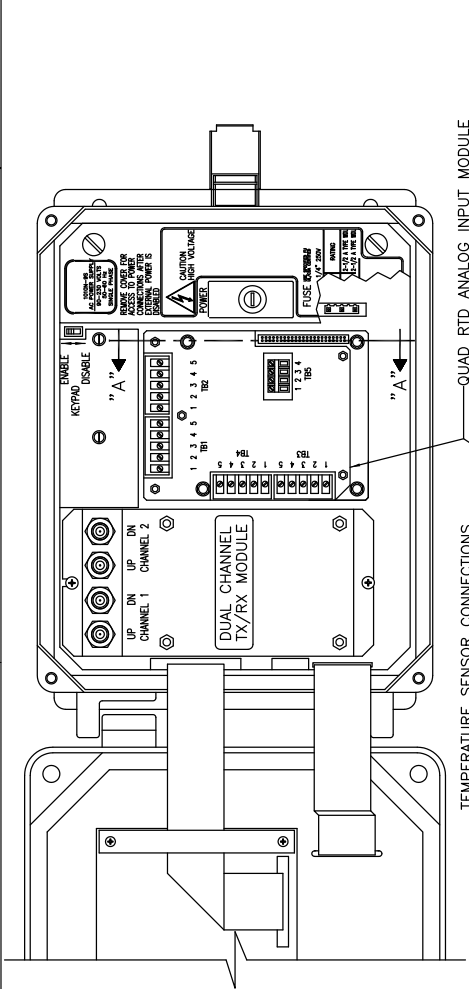

TEMPERATURE SENSOR CONNECTIONS  
(SEE NOTE 4)

T1 OR CH.-1 TS T2 OR CH.-1 TR  
(SUPPLY) (RETURN)

ALTERNATE COLOR CODE FOR CERTAIN 1012EC CABLES:  
WHITE = ORANGE  
GREEN = BROWN

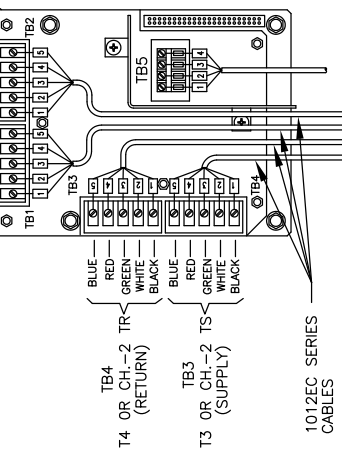

**NOTES:**

1. TERMINAL BLOCK TB1, TB2, TB3, TB4 AND TB5 ARE LUG-LESS WIRE CLAMP TYPE. PROVIDING RELIABLE CONNECTION TO STRIPPED WIRE, AWG. #14-24.
2. SET METER AND INSTRUMENTATION POWER TO OFF WHEN INSERTING OR REMOVING THE MODULE OR WHEN MAKING CONNECTIONS TO TB1, TB2, TB3, TB4 AND TB5
3. REFER TO THE 1010 FIELD MANUAL FOR ADDITIONAL INSTALLATION INFORMATION.
4. USE 1012ECN SERIES CABLES TO CONNECT BETWEEN TEMPERATURE SENSOR INPUT WIRING TERMINALS TB1 THRU TB4 AND 991T OR 1011T SERIES TEMPERATURE SENSORS. NOTE SUPPLY AND RETURN TEMPERATURE SENSOR DESIGNATIONS WHEN USED WITH A 1010E SERIES ENERGY FLOW COMPUTER.
5. FOR INSTALLATION IN HAZARDOUS AREAS SEE CONTROL DRAWING REFERENCED ON TRANSMITTER NAMEPLATE.

**TB1 WIRING**

PIN	COLOR	FUNCTION SEE NOTE 4	DESCRIPTION	WIRING	CABLE LENGTH 1000 FT. MAX.	NOTES
1	BLACK	RTD CURRENT HIGH	RTD TEMPERATURE MEASUREMENT T1 OR CHANNEL-1S (SUPPLY TEMPERATURE)	AWG. 14-24	1000 FT. MAX.	SEE NOTE 3
2	WHITE	RTD VOLTAGE HIGH	T1 OR CHANNEL-1S			WITHOUT FACTORY APPROVAL
3	GREEN	RTD VOLTAGE LOW				
4	RED	RTD CURRENT LOW				
5	BLUE	GROUND				

**TB2 WIRING**

PIN	COLOR	FUNCTION SEE NOTE 4	DESCRIPTION	WIRING	CABLE LENGTH 1000 FT. MAX.	NOTES
1	BLACK	RTD CURRENT HIGH	RTD TEMPERATURE MEASUREMENT T2 OR CHANNEL-2S (RETURN TEMPERATURE)	AWG. 14-24	1000 FT. MAX.	SEE NOTE 3
2	WHITE	RTD VOLTAGE HIGH	T2 OR CHANNEL-2S			WITHOUT FACTORY APPROVAL
3	GREEN	RTD VOLTAGE LOW				
4	RED	RTD CURRENT LOW				
5	BLUE	GROUND				

**TB3 WIRING**

PIN	COLOR	FUNCTION SEE NOTE 4	DESCRIPTION	WIRING	CABLE LENGTH 1000 FT. MAX.	NOTES
1	BLACK	RTD CURRENT HIGH	RTD TEMPERATURE MEASUREMENT T3 OR CHANNEL-2 TS (SUPPLY TEMPERATURE)	AWG. 14-24	1000 FT. MAX.	SEE NOTE 3
2	WHITE	RTD VOLTAGE HIGH				WITHOUT FACTORY APPROVAL
3	GREEN	RTD VOLTAGE LOW				
4	RED	RTD CURRENT LOW				
5	BLUE	GROUND				

**TB4 WIRING**

PIN	COLOR	FUNCTION SEE NOTE 4	DESCRIPTION	WIRING	CABLE LENGTH 1000 FT. MAX.	NOTES
1	BLACK	RTD CURRENT HIGH	RTD TEMPERATURE MEASUREMENT T4 OR CHANNEL-2 TR (RETURN TEMPERATURE)	AWG. 14-24	1000 FT. MAX.	SEE NOTE 3
2	WHITE	RTD VOLTAGE HIGH				WITHOUT FACTORY APPROVAL
3	GREEN	RTD VOLTAGE LOW				
4	RED	RTD CURRENT LOW				
5	BLUE	GROUND				

**TB5 WIRING**

PIN	FUNCTION SEE NOTE 4	USE	DESCRIPTION	BEHAVIOR	LOAD	WIRING	CABLE LENGTH 1000 FT. MAX.	NOTES
1	AUX.1 IN	IN1 INPUT	ANALOG CURRENT INPUT REFERENCED TO METER GROUND	4 TO 20 mA	200.0	AWG. 14-24	1000 FT. MAX.	SEE NOTES 3, 5
2	AUX.1 COM	IN1 COMMON						
3	AUX.2 IN	IN2 INPUT						
4	AUX.2 COM	IN2 COMMON						

CONTROLLED DRAWING  
CHANGES TO BE MADE ONLY BY  
RELEVANT AGENCY APPROVAL



Siemens Industry, Inc.  
Industry Automation Division  
Hawthorne, NY 11788

**INSTALLATION DRAWING  
ANALOG INPUT MODULE**

UNLESS OTHERWISE SPECIFIED: DIMENSIONS ARE IN INCHES TOLERANCES ON— FRACTIONS: DECIMAL ANGLES: HOLES ± 1/64" XX±0.01 ±0/30 ±.003 XXX±0.005	SAP MATERIAL NO.	REV
	ITEM NO.	AS
	DOCUMENT NO.	1010N-5DS2-7
	DATE: 7/18/98	SCALE: NONE
DRAWN BY: H.Jenkins	SHEET	1 OF 1

1  
2  
3  
4

1 2 3 4

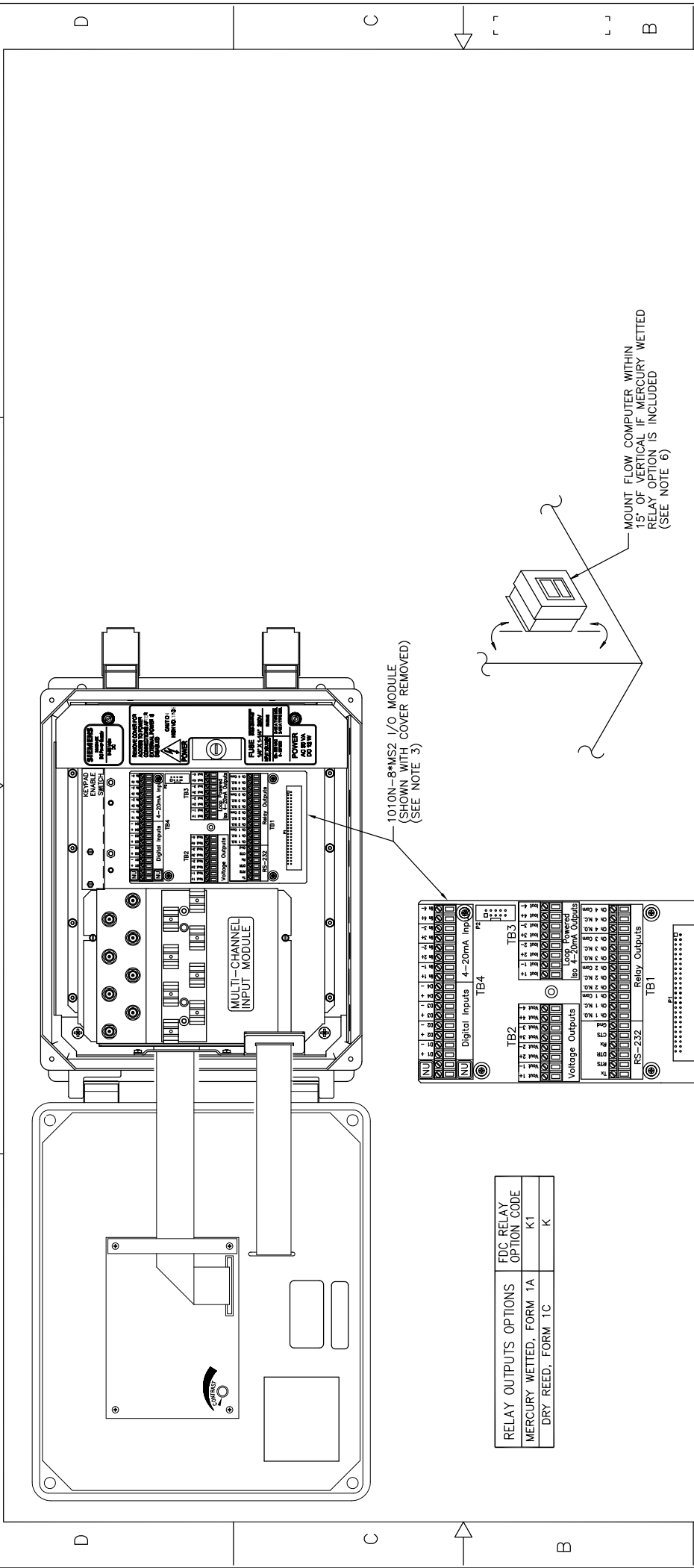

1010N-8\*MS2 I/O MODULE  
(SHOWN WITH COVER REMOVED)  
(SEE NOTE 3)

MOUNT FLOW COMPUTER WITHIN  
15° OF VERTICAL IF MERCURY WETTED  
RELAY OPTION IS INCLUDED  
(SEE NOTE 6)

RELAY OUTPUTS OPTIONS		FDC RELAY OPTION CODE
MERCURY WETTED, FORM 1A		K1
DRY REED, FORM 1C		K

**NOTES:** (CONT'D ON SHT. 2)

1. TERMINAL BLOCKS TB1, TB2, TB3 AND TB4 ARE LUG-LESS WIRE CLAMP TYPE, PROVIDING RELIABLE CONNECTION TO STRIPPED STRANDED WIRE, AWG. #14-24.
2. RELAY TYPE VARIES WITH FLOW COMPUTER OPTION CODE. SEE TABLE, ZONE B4.
3. RELAY CLOSURES AND ANALOG OUTPUTS ARE USER PROGRAMMABLE THROUGH THE 1010 INSTALLATION MENU. SEE THE 1010 FIELD MANUAL AND SHT.2 FOR LIST OF ASSIGNABLE FUNCTIONS.
4. SET METER AND INSTRUMENTATION POWER TO OFF WHEN INSERTING OR REMOVING THE MODULE AND MAKING CONNECTIONS TO TB1, TB2, TB3 AND TB4.
5. REFER TO THE 1010 FIELD MANUAL FOR ADDITIONAL INSTALLATION INFORMATION.
6. WHEN SUPPLIED WITH MERCURY WETTED RELAYS, MOUNT FLOW COMPUTER WITHIN 15° OF VERTICAL, BOTH PLANES, FOR PROPER RELAY OPERATION. (SEE ZONE B2).

**RELATED DRAWING**  
CHANGES TO THIS DRAWING REQUIRE  
CERTIFICATION OF CONFORMANCE WITH  
RELATED CONTROLLED DRAWINGS

UNLESS OTHERWISE SPECIFIED:  
DIMENSIONS ARE IN INCHES  
TOLERANCES ON:  
FRACTIONS DECIMAL ANGLES HOLES  
±.1/64" XX.00.01 .01°30' ±.003  
XXX.00.005

DRAWN BY: H.Jenkins

**SIEMENS**  
Siemens Industry, Inc.  
Industry Automation Division  
Hempstead, NY 11788

**INSTALLATION DRAWING**  
**I/O MODULE**

SAP MATERIAL NO.	REV. —
ITEM NO.	AS —
DOCUMENT NO.	1010N-8MS2-7 DS 03
DATE: 1/14/2012	SCALE: NONE SHEET 1 OF 2

1 2 3 4

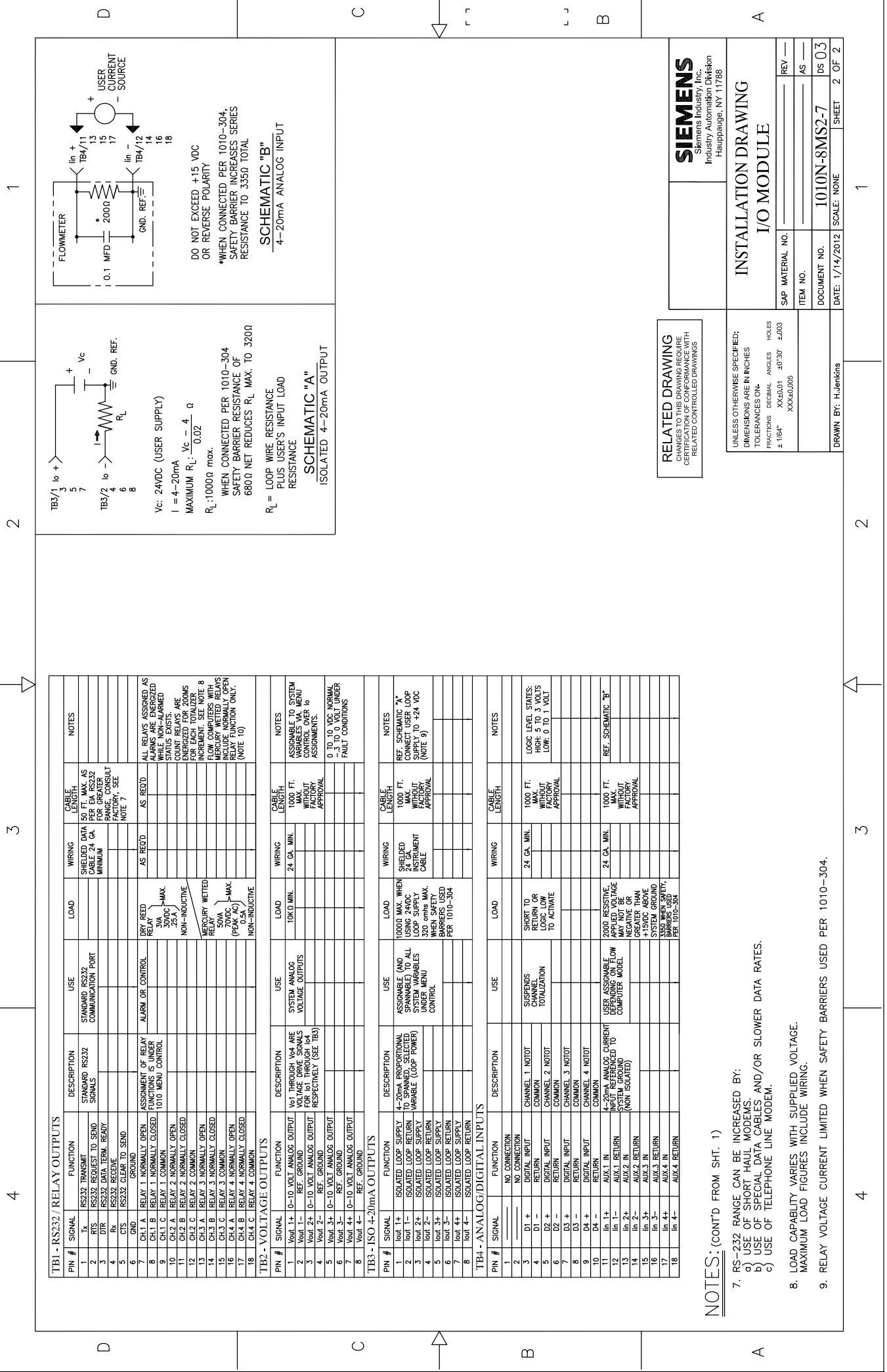

**SIEMENS**  
Siemens Industry, Inc.  
Industry Automation Division  
Hempstead, NY 11788

**INSTALLATION DRAWING**  
**I/O MODULE**

SAP MATERIAL NO.	REV. ---
ITEM NO.	AS ---
DOCUMENT NO.	1010N-8MS2-7 DS 03
DATE: 1/14/2012	SCALE: NONE
DRAWN BY: H.Jenkins	SHEET 2 OF 2

**RELATED DRAWING**  
CHANGES TO THIS DRAWING REQUIRE CERTIFICATION OF CONFORMANCE WITH RELATED CONTROLLED DRAWINGS

UNLESS OTHERWISE SPECIFIED:  
DIMENSIONS ARE IN INCHES  
TOLERANCES ON- HOLES  
FRACTIONS DECIMAL ANGLES  
±.064" XX.001 .40".30" ±.003  
XXX±0.005

**TB1 - RS232 / RELAY OUTPUTS**

PIN #	SIGNAL	FUNCTION	DESCRIPTION	USE	LOAD	WIRING	CABLE LENGTH	NOTES
1	TX	RS232 TRANSMIT	STANDARD RS232 SIGNALS	STANDARD RS232 COMMUNICATION PORT		SHIELDED DATA CABLE 24 GA. MINIMUM	50 FT. MAX. AS PER EA RS232 RANGE CONSULT FACTORY, SEE NOTE 7	
2	RTS	RS232 DATA TERM. READY						
3	DTR	RS232 DATA TERM. READY						
4	Rx	RS232 RECEIVE						
5	CTS	RS232 CLEAR TO SEND						
6	GN	GROUND						
7	CH1.A	RELAY 1 NORMALLY OPEN	ASSIGNMENT OF RELAY 1010 MENU CONTROL	ALARM OR CONTROL	KEY REED RELAY 3VA 20DC 30DC MAX. NON-INDUCTIVE	AS RECD	AS RECD	ALL RELAYS ASSIGNED AS NORMALIZED WHILE NON-ARMED STATUS EXISTS. COUNT RELAYS ARE ENERGIZED FOR ZEMAS INCREASE. SEE NOTE 8 FLOW COMPUTERS WITH MERCURY WETTED RELAYS (PER 1010-304) MAX. 0.5A NON-INDUCTIVE
8	CH1.B	RELAY 1 NORMALLY CLOSED						
9	CH1.C	RELAY 1 COMMON						
10	CH2.A	RELAY 2 NORMALLY OPEN						
11	CH2.B	RELAY 2 NORMALLY CLOSED						
12	CH2.C	RELAY 2 COMMON						
13	CH3.A	RELAY 3 NORMALLY OPEN						
14	CH3.B	RELAY 3 NORMALLY CLOSED						
15	CH3.C	RELAY 3 COMMON						
16	CH4.A	RELAY 4 NORMALLY OPEN						
17	CH4.B	RELAY 4 NORMALLY CLOSED						
18	CH4.C	RELAY 4 COMMON						

**TB2 - VOLTAGE OUTPUTS**

PIN #	SIGNAL	FUNCTION	DESCRIPTION	USE	LOAD	WIRING	CABLE LENGTH	NOTES
1	Vout 1+	0-10 VOLT ANALOG OUTPUT	V <sub>01</sub> THROUGH V <sub>04</sub> ARE VOLTAGE THROUGH I/O MODULES RESPECTIVELY (SEE TB3)	SYSTEM ANALOG VOLTAGE OUTPUTS	10KΩ MIN.	24 GA. MIN.	1000 FT. MAX. WITHOUT FACTORY APPROVAL	ASSIGNABLE TO SYSTEM ANALOG MENU CONTROL OVER I/O
2	Vout 1-	REF. GROUND						
3	Vout 2+	0-10 VOLT ANALOG OUTPUT						
4	Vout 2-	REF. GROUND						
5	Vout 3+	0-10 VOLT ANALOG OUTPUT						
6	Vout 3-	REF. GROUND						
7	Vout 4+	0-10 VOLT ANALOG OUTPUT						
8	Vout 4-	REF. GROUND						

**TB3 - ISO 4-20mA OUTPUTS**

PIN #	SIGNAL	FUNCTION	DESCRIPTION	USE	LOAD	WIRING	CABLE LENGTH	NOTES
1	Iout 1+	ISOLATED LOOP SUPPLY	4-20mA PROPORTIONAL TO SPANNED, SELECTED VARIABLE (LOOP POWER)	ASSIGNABLE (AND SPANNABLE) TO ALL SYSTEM VARIABLES TO ALL SYSTEM MENU CONTROL	1000Ω MAX. WHEN LOOP SUPPLY 320 ohms MAX. BARRIERS USED PER 1010-304	SHIELDED 24 GA. INSTRUMENT CABLE	1000 FT. MAX. WITHOUT FACTORY APPROVAL	REF. SCHEMATIC "A" CONNECT USER LOOP SUPPLY TO +24 VDC (NOTE 9)
2	Iout 1-	ISOLATED LOOP RETURN						
3	Iout 2+	ISOLATED LOOP SUPPLY						
4	Iout 2-	ISOLATED LOOP RETURN						
5	Iout 3+	ISOLATED LOOP SUPPLY						
6	Iout 3-	ISOLATED LOOP RETURN						
7	Iout 4+	ISOLATED LOOP SUPPLY						
8	Iout 4-	ISOLATED LOOP RETURN						

**TB4 - ANALOG/DIGITAL INPUTS**

PIN #	SIGNAL	FUNCTION	DESCRIPTION	USE	LOAD	WIRING	CABLE LENGTH	NOTES
1	---	NO CONNECTION						
2	---	NO CONNECTION						
3	D1+	DIGITAL INPUT	CHANNEL 1 NOTOT COMMON	SUSPENDS CHANNEL TOTALIZATION	SHORT TO RETURN OR LOGIC LOW TO ACTIVATE	24 GA. MIN.	1000 FT. MAX. WITHOUT FACTORY APPROVAL	LOGIC LEVEL STATES: HIGH 0 TO 1 VOLT LOW 0 TO 1 VOLT
4	D1-	DIGITAL INPUT	CHANNEL 2 NOTOT COMMON					
5	D2+	DIGITAL INPUT	CHANNEL 3 NOTOT COMMON					
6	D2-	DIGITAL INPUT	CHANNEL 4 NOTOT COMMON					
7	D3+	DIGITAL INPUT	COMMON					
8	D3-	DIGITAL INPUT	COMMON					
9	D4+	DIGITAL INPUT	COMMON					
10	D4-	DIGITAL INPUT	COMMON					
11	Iin 1+	AUX.1 IN	4-20mA ANALOG CURRENT SYSTEM REFERRED TO (NON ISOLATED)	USER ASSIGNABLE LOW COMPUTER MODEL	2000 RESISTIVE APPLIED VOLTAGE NEGATIVE OR GREATER THAN +15VDC ABOVE SYSTEM GROUND BARRIERS USED PER 1010-304	24 GA. MIN.	1000 FT. MAX. WITHOUT FACTORY APPROVAL	REF. SCHEMATIC "B"
12	Iin 1-	AUX.1 RETURN						
13	Iin 2+	AUX.2 IN						
14	Iin 2-	AUX.2 RETURN						
15	Iin 3+	AUX.3 IN						
16	Iin 3-	AUX.3 RETURN						
17	Iin 4+	AUX.4 IN						
18	Iin 4-	AUX.4 RETURN						

**NOTES:** (CONT'D FROM SHT. 1)

7. RS-232 RANGE CAN BE INCREASED BY:
  - a) USE OF SHORT-HAUL MODEMS;
  - b) USE OF SPECIAL DATA CABLES AND/OR SLOWER DATA RATES.
  - c) USE OF TELEPHONE LINE MODEM.
8. LOAD CAPABILITY VARIES WITH SUPPLIED VOLTAGE. MAXIMUM LOAD FIGURES INCLUDE WIRING.
9. RELAY VOLTAGE CURRENT LIMITED WHEN SAFETY BARRIERS USED PER 1010-304.

**DO NOT EXCEED +15 VDC OR REVERSE POLARITY**  
\*WHEN CONNECTED PER 1010-304 SAFETY BARRIER INCREASES SERIES RESISTANCE TO 335Ω TOTAL

**SCHEMATIC "B"**  
4-20mA ANALOG INPUT

**SCHEMATIC "A"**  
ISOLATED 4-20mA OUTPUT

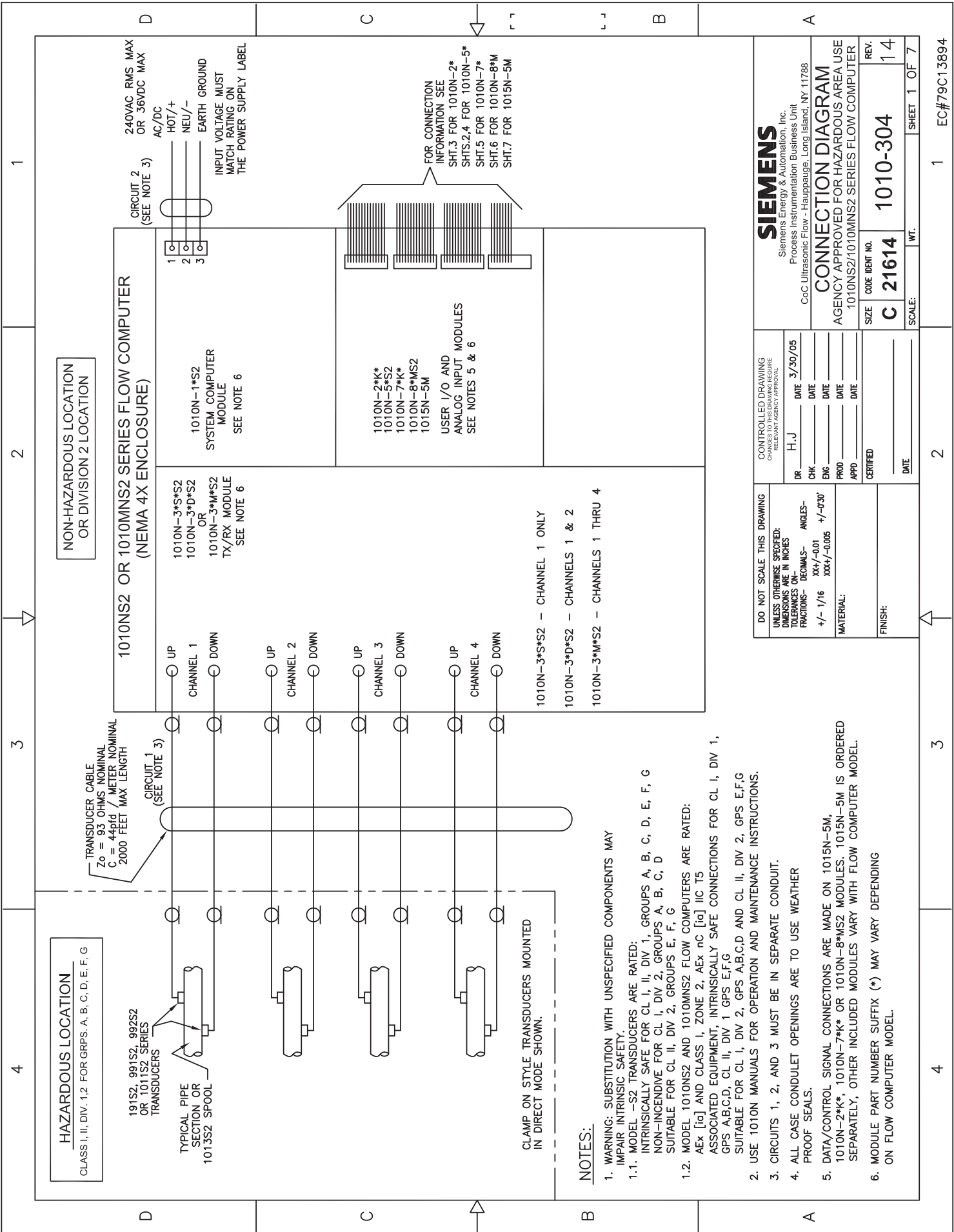

NON-HAZARDOUS LOCATION  
OR DIVISION 2 LOCATION

HAZARDOUS LOCATION  
CLASS I, II, DIV. 1,2 FOR GRPS. A, B, C, D, E, F, G

1010NS2 OR 1010MNS2 SERIES FLOW COMPUTER  
(NEMA 4X ENCLOSURE)

1010N-3\*S\*S2  
OR  
1010N-3\*D\*S2  
1010N-3\*M\*S2  
TX/RX MODULE  
SEE NOTE 6

UP  
CHANNEL 1  
DOWN

UP  
CHANNEL 2  
DOWN

UP  
CHANNEL 3  
DOWN

UP  
CHANNEL 4  
DOWN

1010N-3\*S\*S2 - CHANNEL 1 ONLY  
1010N-3\*D\*S2 - CHANNELS 1 & 2  
1010N-3\*M\*S2 - CHANNELS 1 THRU 4

CIRCUIT 2  
(SEE NOTE 3)

240VAC RMS MAX  
OR 36VDC MAX  
AC/DC  
HOT/+  
NEU/+  
EARTH GROUND

INPUT VOLTAGE MUST  
MATCH RATING ON  
THE POWER SUPPLY LABEL

1010N-2\*K\*  
1010N-5\*S2  
1010N-7\*K\*  
1010N-8\*M\*S2  
1015N-5M

USER I/O AND  
ANALOG INPUT MODULES  
SEE NOTES 5 & 6

FOR CONNECTION  
INFORMATION SEE  
SHT.3 FOR 1010N-2\*  
SHTS.2,4 FOR 1010N-5\*  
SHT.5 FOR 1010N-7\*  
SHT.6 FOR 1010N-8\*M  
SHT.7 FOR 1015N-5M

TRANSducer CABLE  
 $Z_0 = 93 \text{ OHMS}$  NOMINAL  
 $C = 44 \text{ pfd}$  / METER NOMINAL  
2000 FEET MAX LENGTH

191S2, 991S2, 992S2  
OR 1011S2 SERIES  
TRANSDUCERS

TYPICAL PIPE  
SECTION OR  
1013S2 SPOOL

CLAMP ON STYLE TRANSDUCERS MOUNTED  
IN DIRECT MODE SHOWN.

**NOTES:**

- WARNING: SUBSTITUTION WITH UNSPECIFIED COMPONENTS MAY IMPAIR INTRINSIC SAFETY.
- 1.1. MODEL -S2 TRANSDUCERS ARE RATED:  
INTRINSICALLY SAFE FOR CL I, II, DIV 1, GROUPS A, B, C, D, E, F, G  
NON-INCENDIVE FOR CL I, DIV 2, GROUPS A, B, C, D  
SUITABLE FOR CL II, DIV 2, GROUPS E, F, G
- 1.2. MODEL 1010NS2 AND 1010MNS2 FLOW COMPUTERS ARE RATED:  
AEx [ia] AND CLASS I, ZONE 2, AEx nC [ic] IIC T5  
ASSOCIATED EQUIPMENT, INTRINSICALLY SAFE CONNECTIONS FOR CL I, DIV 1, GPS A,B,C,D, CL II, DIV 1 GPS E,F,G  
SUITABLE FOR CL I, DIV 2, GPS A,B,C,D AND CL II, DIV 2, GPS E,F,G
- USE 1010N MANUALS FOR OPERATION AND MAINTENANCE INSTRUCTIONS.
- CIRCUITS 1, 2, AND 3 MUST BE IN SEPARATE CONDUIT.
- ALL CASE CONDULET OPENINGS ARE TO USE WEATHER PROOF SEALS.
- DATA/CONTROL SIGNAL CONNECTIONS ARE MADE ON 1015N-5M, 1010N-2\*K\*, 1010N-7\*K\* OR 1010N-8\*M\*S2 MODULES. 1015N-5M IS ORDERED SEPARATELY, OTHER INCLUDED MODULES VARY WITH FLOW COMPUTER MODEL.
- MODULE PART NUMBER SUFFIX (\*) MAY VARY DEPENDING ON FLOW COMPUTER MODEL.

DO NOT SCALE THIS DRAWING UNLESS OTHERWISE SPECIFIED: DIMENSIONS - DECIMALS - ANGLES - FRACTIONS - INCHES +/- 1/16    xx +/- 0.01    +/- 0*30' xxx +/- 0.005    +/ - 0*30'		CONTROLLED DRAWING CHANGES TO THIS DRAWING REQUIRE RELEVANT AGENCY APPROVAL		SIEMENS Siemens Energy & Automation, Inc. Process Instrumentation Business Unit CoC Ultrasonic Flow - Hauppauge, Long Island, NY 11788	
DR	HJJ	DATE	3/30/05	CONNECTION DIAGRAM	
CHK		DATE		AGENCY APPROVED FOR HAZARDOUS AREA USE 1010NS2/1010MNS2 SERIES FLOW COMPUTER	
ENG		DATE		SIZE	C 21614 1010-304
PROO		DATE		CODE IDENT NO.	1010-304
APPD		DATE		REV.	14
CERTIFIED		DATE		SCALE:	SHEET 1 OF 7

4 3 2 1

**HAZARDOUS LOCATION**  
CLASS I, II, DIV. 1, 2 FOR GRFS-A, B, C, D, E, F, G

**NON-HAZARDOUS LOCATION**  
OR DIVISION 2 LOCATION

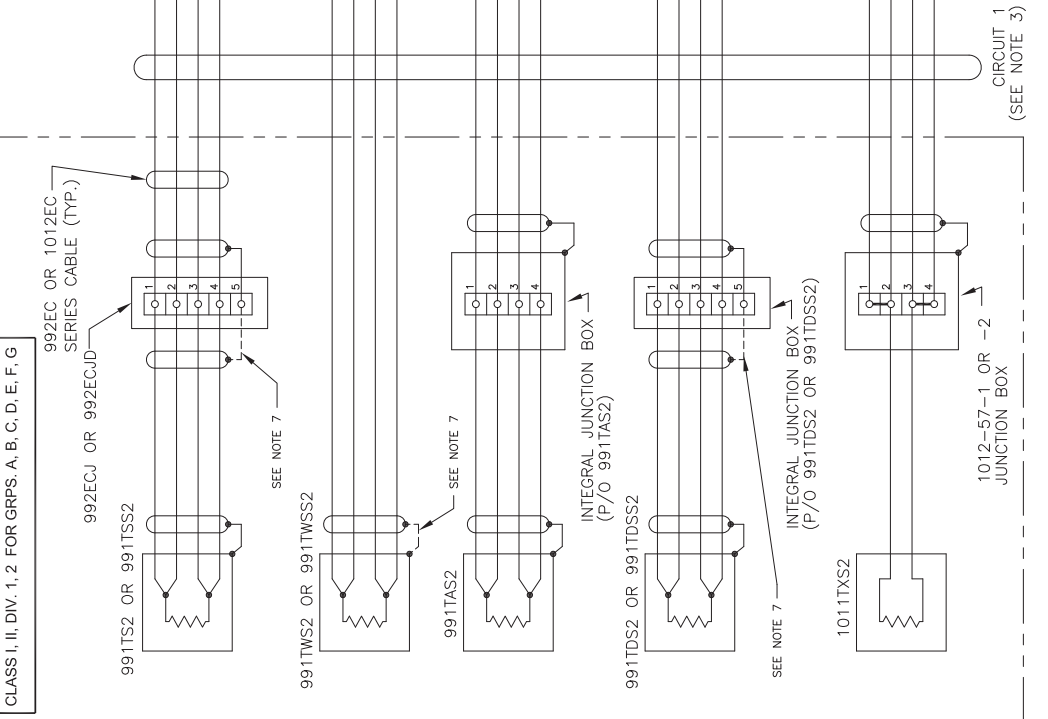
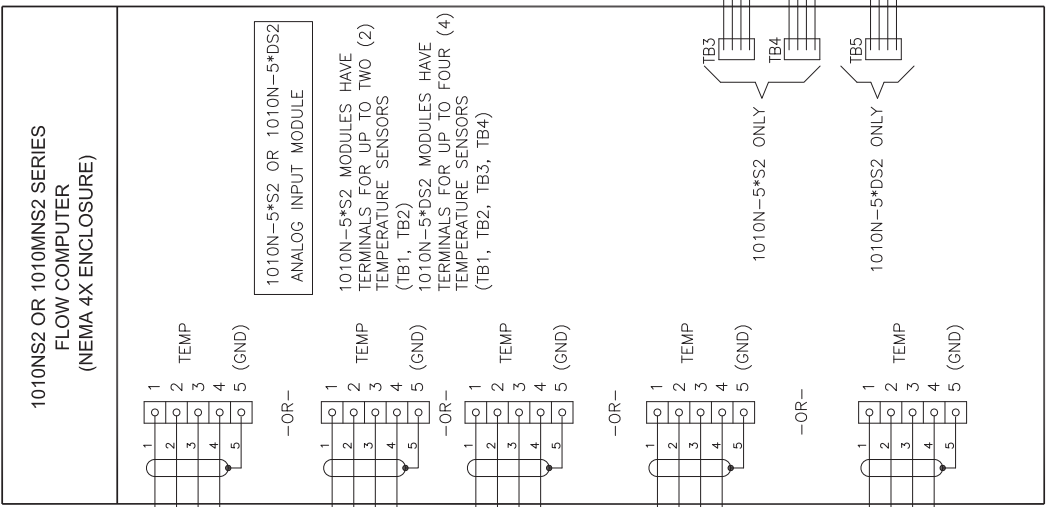

<b>DO NOT SCALE THIS DRAWING</b> UNLESS OTHERWISE SPECIFIED: DIMENSIONS ARE IN INCHES FRACTIONS—DECIMALS— ANGLES— +/— 1/16 XX+/—0.01 +/—0°30' XXX/—0.005		<b>CONTROLLED DRAWING</b> CHANGES TO THIS DRAWING REQUIRE RELEVANT AGENCY APPROVAL DR: H, J DATE: 3/30/05 CHK: _____ DATE: _____ ENG: _____ DATE: _____ APPD: _____ DATE: _____ CERTIFIED: _____ DATE: _____	
<b>SIEMENS</b> Siemens Energy & Automation, Inc. Process Instrumentation Business Unit CoC Ultrasonic Flow - Hauppauge, Long Island, NY 11788		<b>CONNECTION DIAGRAM</b> AGENCY APPROVED FOR HAZARDOUS AREA USE 1010NS2/1010MNS2 SERIES FLOW COMPUTER	
SIZE: C CODE IDENT NO.: 21614	1010-304	REV. 14	SHEET 2 OF 7

OPTIONAL SHIELD CONNECTION

**NOTES:**

7. INDICATED SHIELD CONNECTIONS ARE OPTIONAL AND DO NOT AFFECT SAFETY.

4 3 2 1

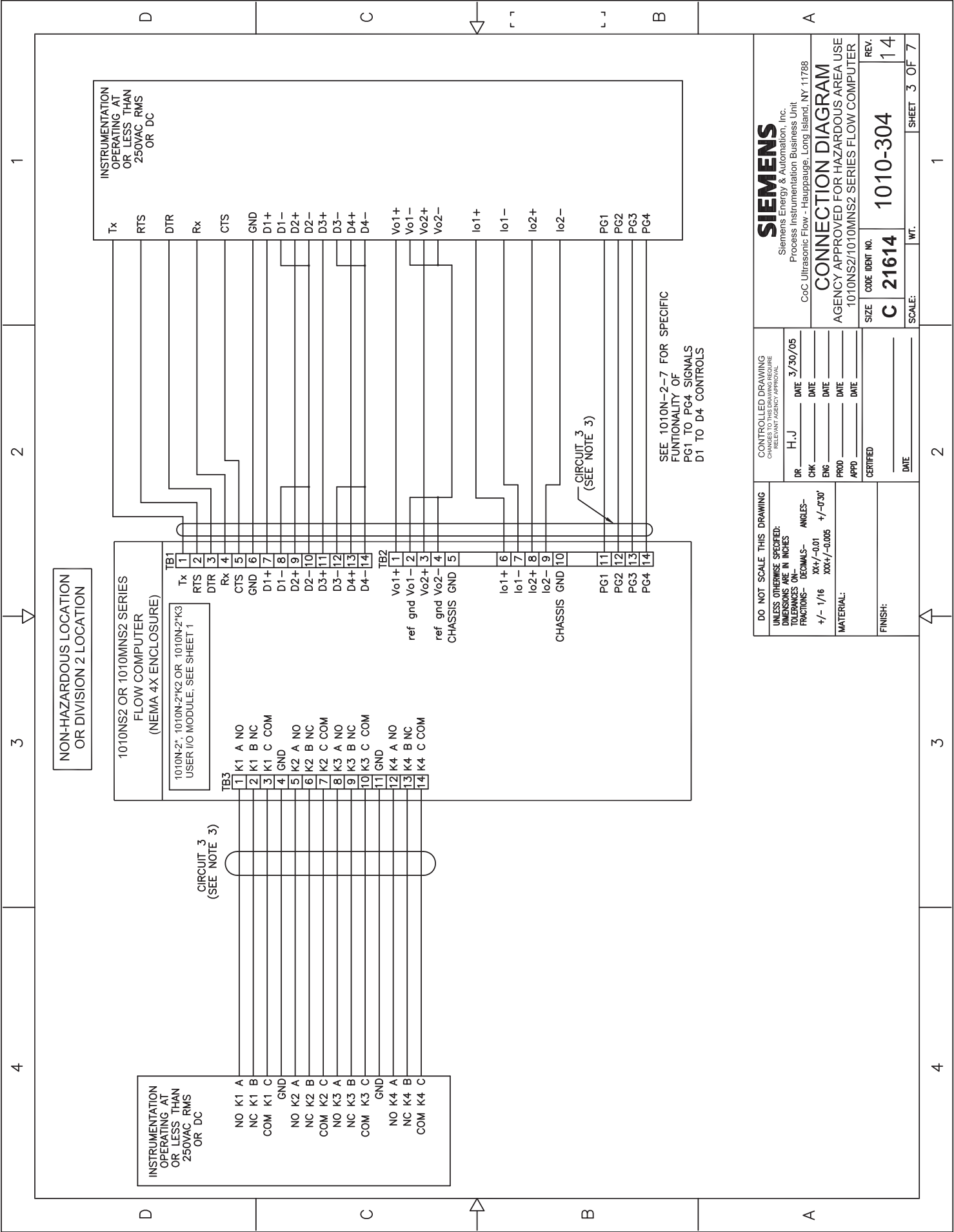

NON-HAZARDOUS LOCATION  
OR DIVISION 2 LOCATION

1010NS2 OR 1010MNS2 SERIES  
FLOW COMPUTER  
(NEMA 4X ENCLOSURE)

1010N-2, 1010N-2/K2 OR 1010N-2/K3  
USER I/O MODULE, SEE SHEET 1

- TB3
- 1 K1 A NO
  - 2 K1 B NC
  - 3 K1 C COM
  - 4 GND
  - 5 K2 A NO
  - 6 K2 B NC
  - 7 K2 C COM
  - 8 K3 A NO
  - 9 K3 B NC
  - 10 K3 C COM
  - 11 GND
  - 12 K4 A NO
  - 13 K4 B NC
  - 14 K4 C COM

CIRCUIT 3  
(SEE NOTE 3)

INSTRUMENTATION  
OPERATING AT  
OR LESS THAN  
250VAC RMS  
OR DC

- Tx
- RTS
- DTR
- Rx
- CTS
- GND
- D1+
- D1-
- D2+
- D2-
- D3+
- D3-
- D4+
- D4-
- Vo1+
- Vo1-
- Vo2+
- Vo2-
- lo1+
- lo1-
- lo2+
- lo2-
- PG1
- PG2
- PG3
- PG4

- TB1
- 1 Tx
  - 2 RTS
  - 3 DTR
  - 4 Rx
  - 5 CTS
  - 6 GND
  - 7 D1+
  - 8 D1-
  - 9 D2+
  - 10 D2-
  - 11 D3+
  - 12 D3-
  - 13 D4+
  - 14 D4-

- Vo1+
- Vo1-
- Vo2+
- Vo2-
- CHASSIS GND
- lo1+
- lo1-
- lo2+
- lo2-
- CHASSIS GND
- PG1
- PG2
- PG3
- PG4

CIRCUIT 3  
(SEE NOTE 3)

SEE 1010N-2-7 FOR SPECIFIC  
FUNCTIONALITY OF  
PG1 TO PG4 SIGNALS  
D1 TO D4 CONTROLS

<b>DO NOT SCALE THIS DRAWING</b> UNLESS OTHERWISE SPECIFIED: DIMENSIONS - IN INCHES FRACTIONS - DECIMALS - ANGLES - +/- 1/16 XX +/- 0.01 +/- 0.30 XXX +/- 0.005	<b>CONTROLLED DRAWING</b> CHANGES TO THIS DRAWING REQUIRE RELEVANT AGENCY APPROVAL		<b>SIEMENS</b> Siemens Energy & Automation, Inc. Process Instrumentation Business Unit CoC Ultrasonic Flow - Hauppauge, Long Island, NY 11788	
	DR: H.J. CHK: _____ ENG: _____ PRD: _____ APP: _____ CERTIFIED: _____ DATE: _____	DATE: 3/30/05 DATE: _____ DATE: _____ DATE: _____	<b>CONNECTION DIAGRAM</b> AGENCY APPROVED FOR HAZARDOUS AREA USE 1010NS2/1010MNS2 SERIES FLOW COMPUTER	
MATERIAL:	SIZE: C	CODE IDENT NO.: 21614	REV.: 14	SCALE: 3 OF 7
FINISH:				

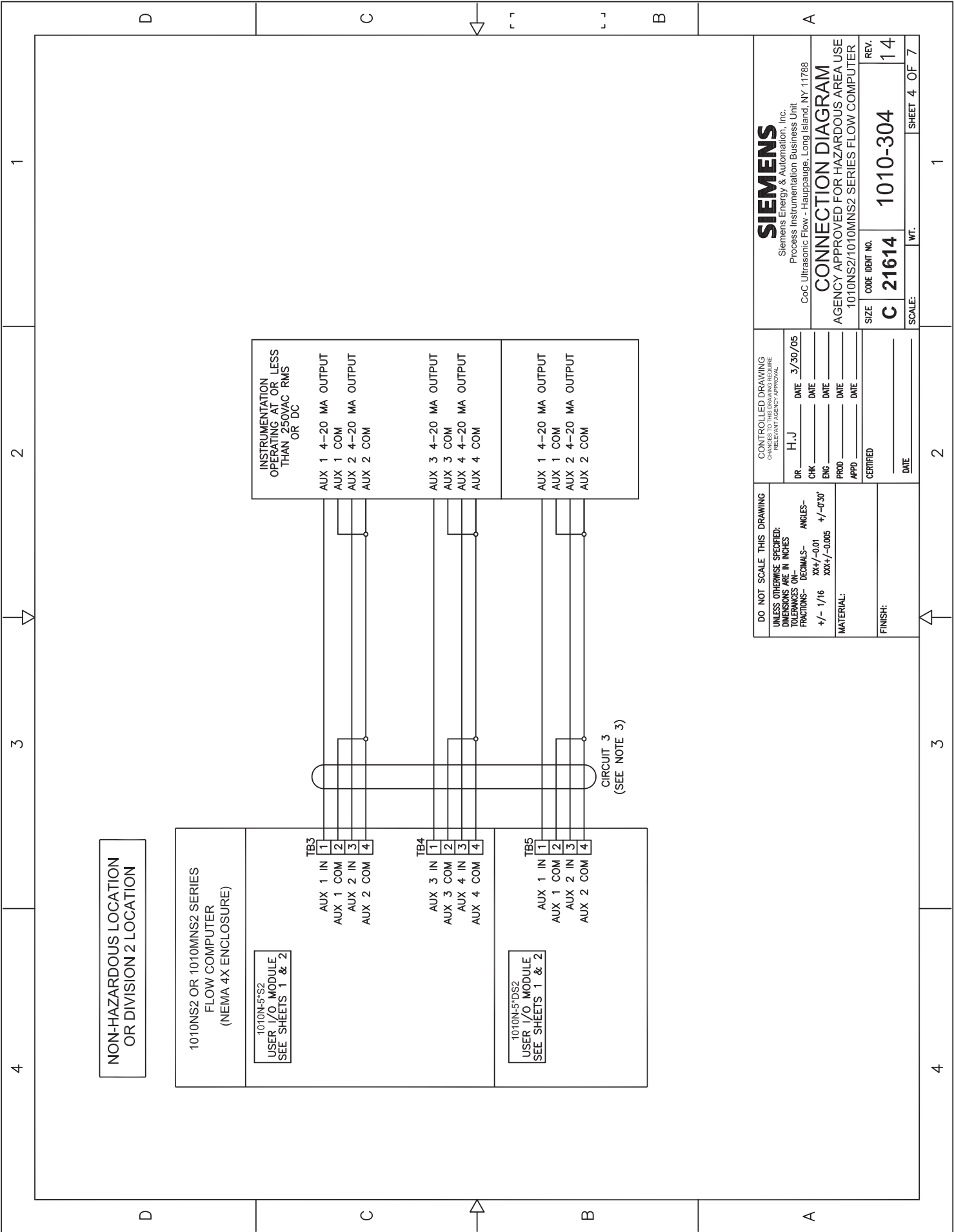

NON-HAZARDOUS LOCATION  
OR DIVISION 2 LOCATION

1010NS2 OR 1010MNS2 SERIES  
FLOW COMPUTER  
(NEMA 4X ENCLOSURE)

1010N-5\*S2  
USER I/O MODULE  
SEE SHEETS 1 & 2

TB3  
AUX 1 IN 1  
AUX 1 COM 2  
AUX 2 IN 3  
AUX 2 COM 4

TB4  
AUX 3 IN 1  
AUX 3 COM 2  
AUX 4 IN 3  
AUX 4 COM 4

TB5  
AUX 1 IN 1  
AUX 1 COM 2  
AUX 2 IN 3  
AUX 2 COM 4

INSTRUMENTATION  
OPERATING AT OR LESS  
THAN 250VAC RMS  
OR DC

AUX 1 4-20 MA OUTPUT  
AUX 1 COM  
AUX 2 4-20 MA OUTPUT  
AUX 2 COM

AUX 3 4-20 MA OUTPUT  
AUX 3 COM  
AUX 4 4-20 MA OUTPUT  
AUX 4 COM

AUX 1 4-20 MA OUTPUT  
AUX 1 COM  
AUX 2 4-20 MA OUTPUT  
AUX 2 COM

CIRCUIT 3  
(SEE NOTE 3)

DO NOT SCALE THIS DRAWING UNLESS OTHERWISE SPECIFIED: DIMENSIONS ARE IN INCHES TOLERANCES- DECIMALS- ANGLES- FRACTIONS- XXX/-0.01 +/--0.30 +/- 1/16 XXX/-0.006 +/--0.30 MATERIAL: FINISH:	CONTROLLED DRAWING CHANGES TO THIS DRAWING REQUIRE RELEVANT AGENCY APPROVAL	SIEMENS Siemens Energy & Automation, Inc. Process Instrumentation Business Unit CoC Ultrasonic Flow - Hauppauge, Long Island, NY 11788
	DR H.J. CHK _____ ENG _____ PRD _____ APPD _____ CERTIFIED _____ DATE _____	DATE 3/30/05 DATE _____ DATE _____ DATE _____ DATE _____
SIZE C CODE IDENT NO. 21614 REV. 14	SCALE: _____ WT. _____ SHEET 4 OF 7	1010-304 14

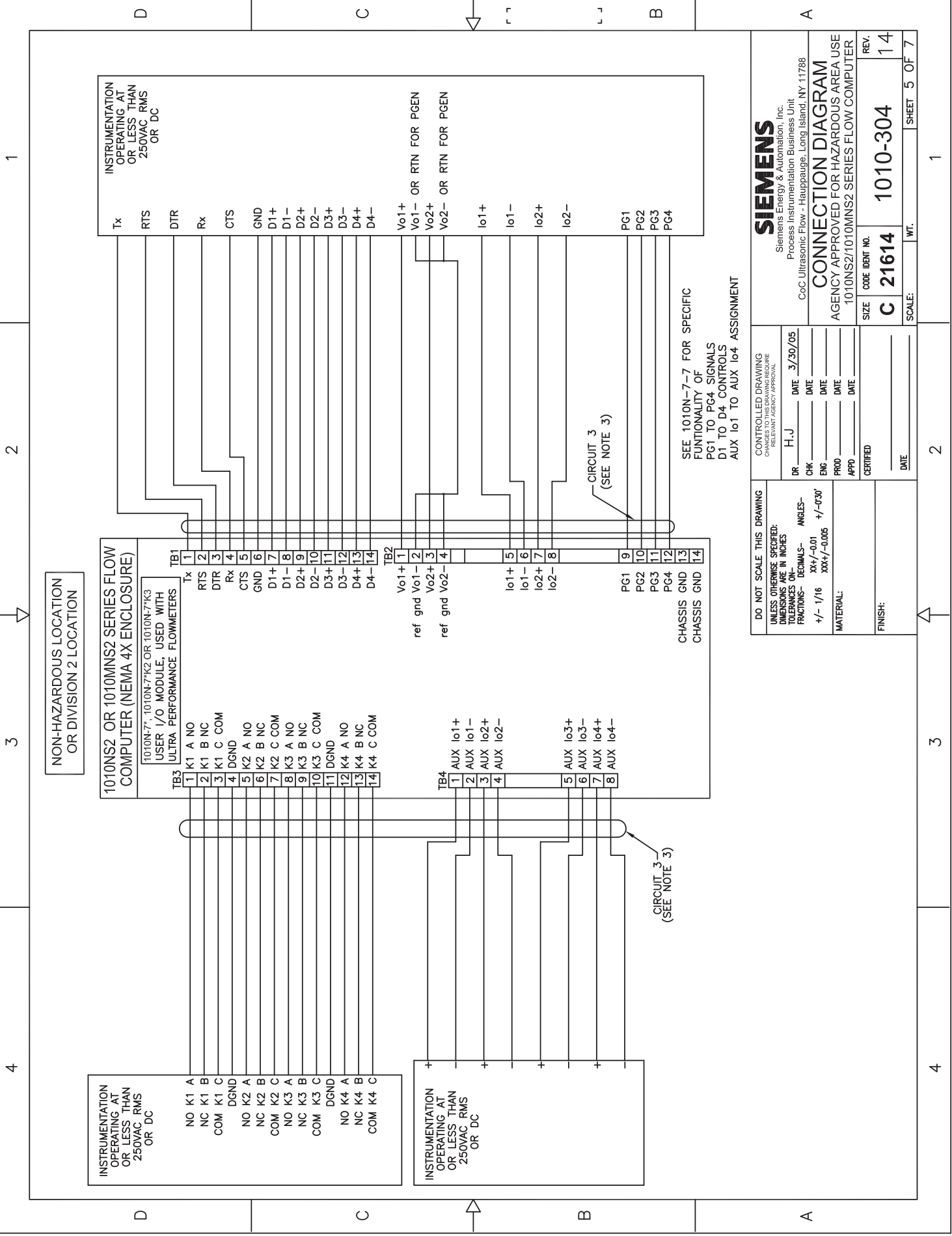

NON-HAZARDOUS LOCATION  
OR DIVISION 2 LOCATION

1010NS2 OR 1010MNS2 SERIES FLOW  
COMPUTER (NEMA 4X ENCLOSURE)

1010N-7\*, 1010N-7K2 OR 1010N-7K3  
USER I/O MODULE. USED WITH  
ULTRA PERFORMANCE FLOWMETERS

INSTRUMENTATION  
OPERATING AT  
OR LESS THAN  
250VAC RMS  
OR DC

NO K1 A  
NC K1 B  
COM K1 C  
DGND  
NO K2 A  
NC K2 B  
COM K2 C  
NO K3 A  
NC K3 B  
COM K3 C  
DGND  
NO K4 A  
NC K4 B  
COM K4 C

INSTRUMENTATION  
OPERATING AT  
OR LESS THAN  
250VAC RMS  
OR DC

1 AUX lo1+  
2 AUX lo1-  
3 AUX lo2+  
4 AUX lo2-  
5 AUX lo3+  
6 AUX lo3-  
7 AUX lo4+  
8 AUX lo4-

TB1  
1 Tx  
2 RTS  
3 DTR  
4 Rx  
5 CTS  
6 GND  
7 D1+  
8 D1-  
9 D2+  
10 D2-  
11 D3+  
12 D3-  
13 D4+  
14 D4-

TB2  
1 Vo1+  
2 Vo1-  
3 Vo2+  
4 Vo2-  
5 lo1+  
6 lo1-  
7 lo2+  
8 lo2-  
9 PG1  
10 PG2  
11 PG3  
12 PG4  
13 CHASSIS GND  
14 CHASSIS GND

TB3  
1 K1 A NO  
2 K1 B NC  
3 K1 C COM  
4 DGND  
5 K2 A NO  
6 K2 B NC  
7 K2 C COM  
8 K3 A NO  
9 K3 B NC  
10 K3 C COM  
11 DGND  
12 K4 A NO  
13 K4 B NC  
14 K4 C COM

TB4  
1 AUX lo1+  
2 AUX lo1-  
3 AUX lo2+  
4 AUX lo2-  
5 AUX lo3+  
6 AUX lo3-  
7 AUX lo4+  
8 AUX lo4-

ref gnd  
ref gnd

CIRCUIT 3  
(SEE NOTE 3)

CIRCUIT 3  
(SEE NOTE 3)

SEE 1010N-7-7 FOR SPECIFIC  
FUNCTIONALITY OF  
PG1 TO PG4 SIGNALS  
D1 TO D4 CONTROLS  
AUX lo1 TO AUX lo4 ASSIGNMENT

DO NOT SCALE THIS DRAWING UNLESS OTHERWISE SPECIFIED: DIMENSIONS ARE IN INCHES FRACTIONS- DECIMALS- ANGLES- +/- 1/16 XX +/- .001 +/- .030 XXX +/- .005		CONTROLLED DRAWING CHANGES TO THIS DRAWING REQUIRE RELEVANT AGENCY APPROVAL	
DR	H.J.	DATE	3/30/05
CHK		DATE	
ENG		DATE	
PROD		DATE	
APPD		DATE	
CERTIFIED			
DATE			
MATERIAL:		SIZE	CODE IDENT NO.
FINISH:		C	21614
		REV.	14
		SCALE:	1010-304
		WT.	
		SHEET	5 OF 7

**SIEMENS**  
Siemens Energy & Automation, Inc.  
Process Instrumentation Business Unit  
CoC Ultrasonic Flow - Hauppauge, Long Island, NY 11788

**CONNECTION DIAGRAM**  
AGENCY APPROVED FOR HAZARDOUS AREA USE  
1010NS2/1010MNS2 SERIES FLOW COMPUTER



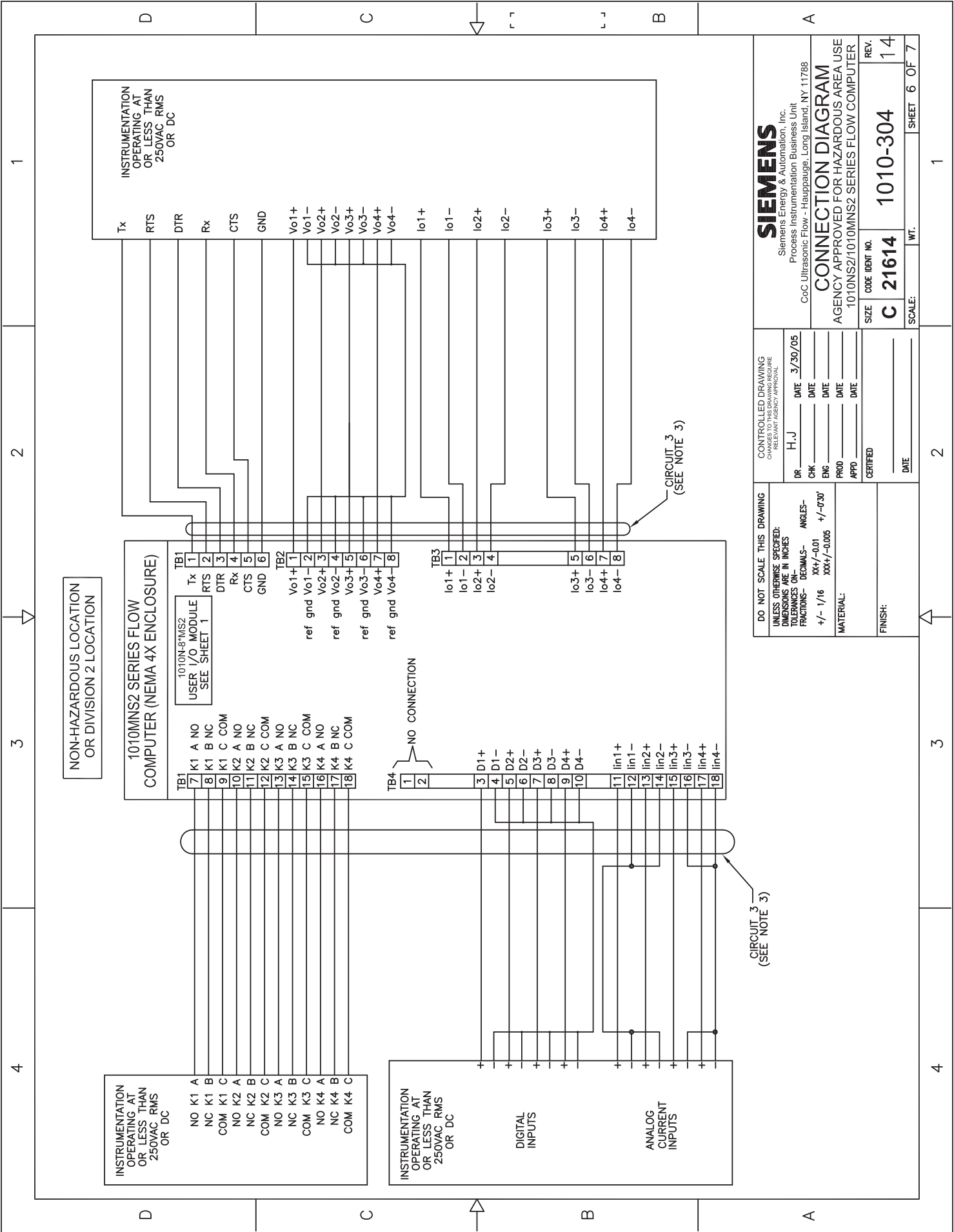

NON-HAZARDOUS LOCATION  
OR DIVISION 2 LOCATION

1010MNS2 SERIES FLOW  
COMPUTER (NEMA 4X ENCLOSURE)

1010N-8\*MS2  
USER I/O MODULE  
SEE SHEET 1

INSTRUMENTATION  
OPERATING AT  
OR LESS THAN  
250VAC RMS  
OR DC

NO K1 A NO  
NC K1 B NC  
COM K1 C COM  
NO K2 A NO  
NC K2 B NC  
COM K2 C COM  
NO K3 A NO  
NC K3 B NC  
COM K3 C COM  
NO K4 A NO  
NC K4 B NC  
COM K4 C COM

INSTRUMENTATION  
OPERATING AT  
OR LESS THAN  
250VAC RMS  
OR DC

DIGITAL  
INPUTS

ANALOG  
CURRENT  
INPUTS

CIRCUIT 3  
(SEE NOTE 3)

CIRCUIT 3  
(SEE NOTE 3)

DO NOT SCALE THIS DRAWING  
UNLESS OTHERWISE SPECIFIED:  
DIMENSIONS IN INCHES  
TOLERANCES ON  
FRACTIONS- DECIMALS- ANGLES-  
+/- 1/16 XXX/-0.01 +/- 0.30  
XXX/-0.005

MATERIAL:  
FINISH:

CONTROLLED DRAWING  
CHANGES TO THIS DRAWING REQUIRE  
RELEVANT AGENCY APPROVAL

DR H.J DATE 3/30/05  
CHK \_\_\_\_\_ DATE \_\_\_\_\_  
ENG \_\_\_\_\_ DATE \_\_\_\_\_  
PRD \_\_\_\_\_ DATE \_\_\_\_\_  
APPD \_\_\_\_\_ DATE \_\_\_\_\_  
CERTIFIED \_\_\_\_\_  
DATE \_\_\_\_\_

**SIEMENS**  
Siemens Energy & Automation, Inc.  
Process Instrumentation Business Unit  
CoC Ultrasonic Flow - Hauppauge, Long Island, NY 11788

**CONNECTION DIAGRAM**  
AGENCY APPROVED FOR HAZARDOUS AREA USE  
1010MNS2/1010MNS2 SERIES FLOW COMPUTER

SIZE CODE IDENT NO. **C 21614** 1010-304  
REV. 14  
SCALE: WT. SHEET 6 OF 7

4 3 2 1

1 2 3 4

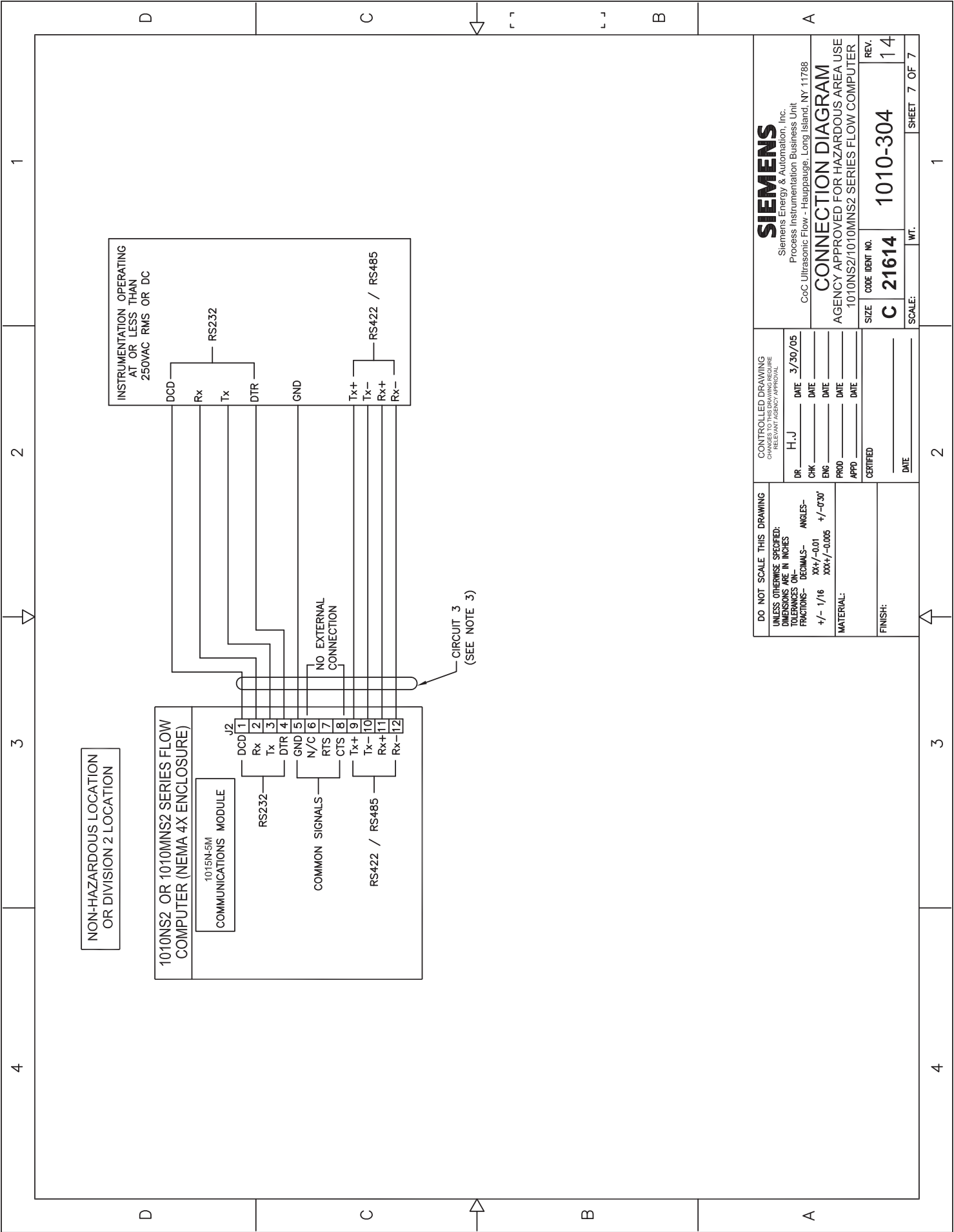

NON-HAZARDOUS LOCATION  
OR DIVISION 2 LOCATION

1015N-5M  
COMMUNICATIONS MODULE

1010NS2 OR 1010MNS2 SERIES FLOW  
COMPUTER (NEMA 4X ENCLOSURE)

J2

DCD 1  
Rx 2  
Tx 3  
DTR 4  
GND 5  
N/C 6  
RTS 7  
CTS 8  
Tx+ 9  
Tx- 10  
Rx+ 11  
Rx- 12

RS232

COMMON SIGNALS

RS422 / RS485

INSTRUMENTATION OPERATING  
AT OR LESS THAN  
250VAC RMS OR DC

DCD  
Rx  
Tx  
DTR  
GND  
Tx+  
Tx-  
Rx+  
Rx-

RS232

RS422 / RS485

NO EXTERNAL  
CONNECTION

CIRCUIT 3  
(SEE NOTE 3)

DO NOT SCALE THIS DRAWING UNLESS OTHERWISE SPECIFIED: DIMENSIONS ARE IN INCHES TOLERANCES - FRACTIONS - ANGLES - DECIMALS - +/- 1/16 XX +/- 0.01 +/- 0.30 XXX +/- 0.006	CONTROLLED DRAWING CHANGES TO THIS DRAWING REQUIRE RELEVANT AGENCY APPROVAL		<b>SIEMENS</b> Siemens Energy & Automation, Inc. Process Instrumentation Business Unit CoC Ultrasonic Flow - Hauppauge, Long Island, NY 11788	
	DR H.J CHK ENG PRD APPD CERTIFIED DATE	DATE 3/30/05 DATE DATE DATE	<b>CONNECTION DIAGRAM</b> AGENCY APPROVED FOR HAZARDOUS AREA USE 1010NS2/1010MNS2 SERIES FLOW COMPUTER	
MATERIAL: FINISH:		SIZE CODE IDENT NO. <b>C 21614</b>	REV. <b>14</b>	SCALE: WT. SHEET 7 OF 7



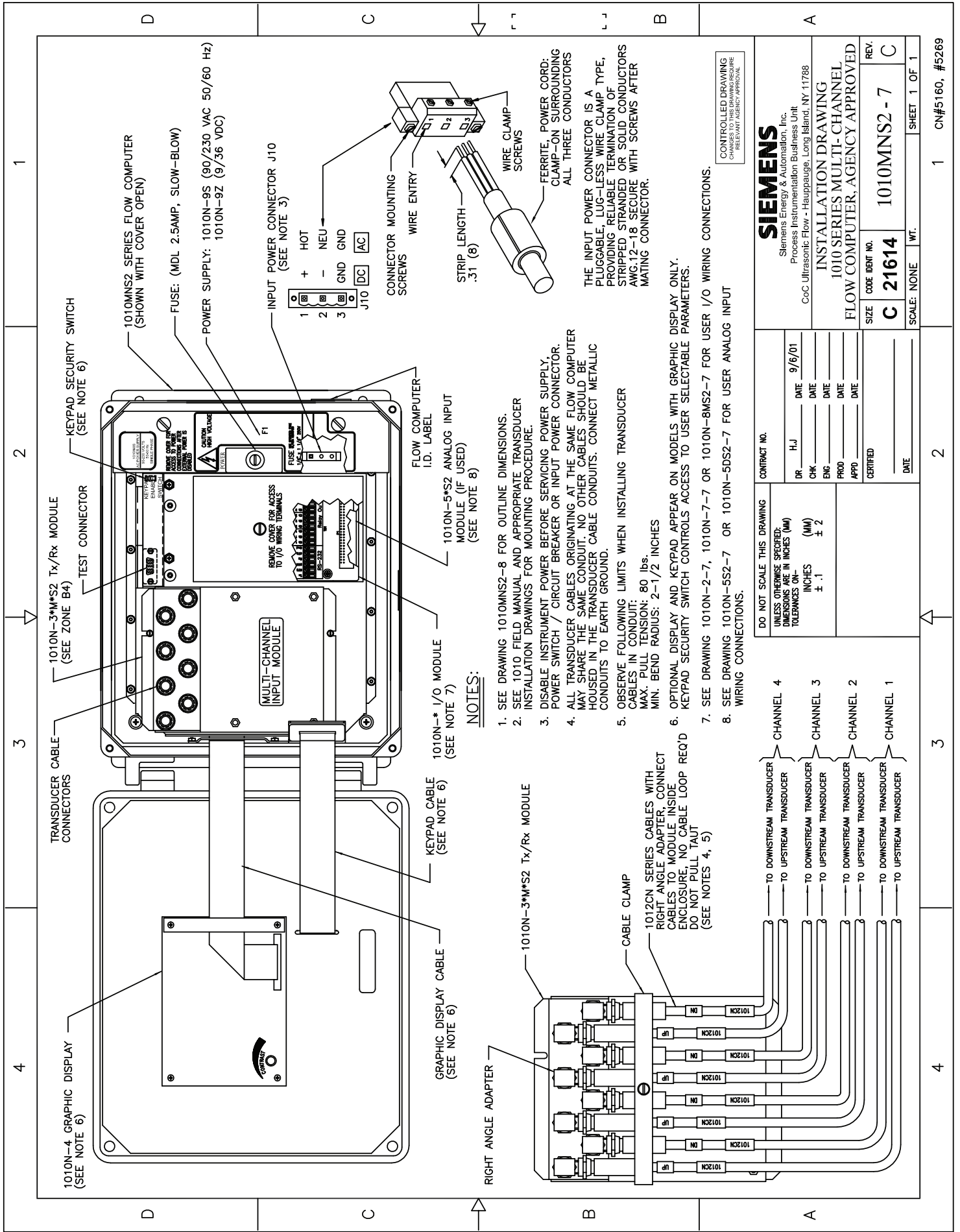



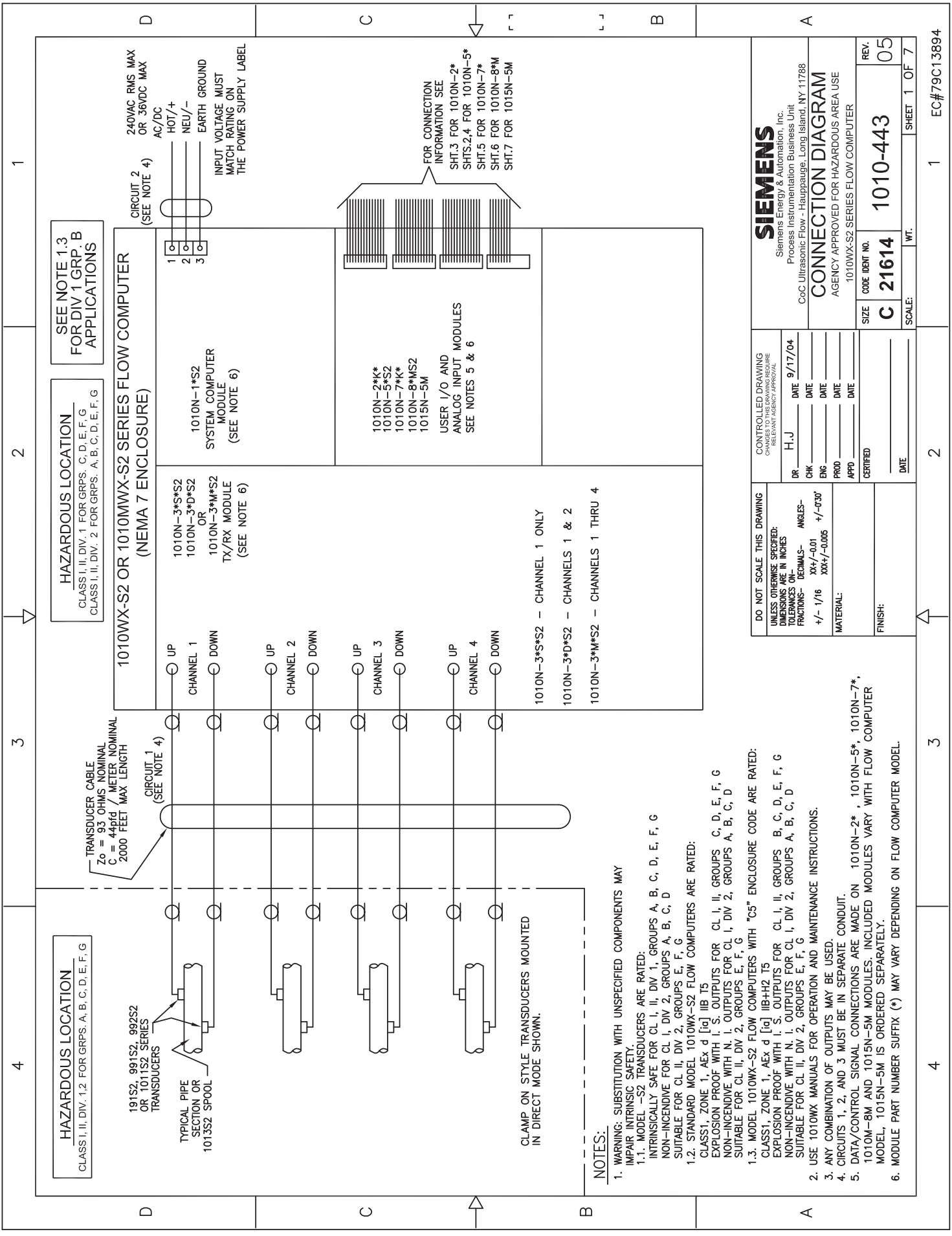

SEE NOTE 1.3 FOR DIV 1 GRP. B APPLICATIONS

**HAZARDOUS LOCATION**  
CLASS I, II, DIV. 1 FOR GRPS. C, D, E, F, G  
CLASS I, II, DIV. 2 FOR GRPS. A, B, C, D, E, F, G

**1010WX-S2 OR 1010MWX-S2 SERIES FLOW COMPUTER**  
(NEMA 7 ENCLOSURE)

1010N-3\*S\*S2  
1010N-3\*D\*S2  
OR  
1010N-3\*M\*S2  
TX/RX MODULE  
(SEE NOTE 6)

1010N-1\*S2  
SYSTEM COMPUTER  
MODULE  
(SEE NOTE 6)

1010N-2\*K\*  
1010N-5\*S2  
1010N-7\*K\*  
1010N-8\*MS2  
1015N-5M  
USER I/O AND  
ANALOG INPUT MODULES  
SEE NOTES 5 & 6

FOR CONNECTION INFORMATION SEE  
SHT.3 FOR 1010N-2\*  
SHT.2.4 FOR 1010N-5\*  
SHT.5 FOR 1010N-7\*  
SHT.6 FOR 1010N-8\*  
SHT.7 FOR 1015N-5M

TRANSUCER CABLE  
 $Z_0 = 93$  OHMS NOMINAL  
 $C = 44pfd$  / METER NOMINAL  
2000 FEET MAX LENGTH

CIRCUIT 1  
(SEE NOTE 4)

191S2, 991S2, 992S2  
OR 1011S2 SERIES  
TRANSUCERS

TYPICAL PIPE SECTION OR 1013S2 SPOOL

CLAMP ON STYLE TRANSUCERS MOUNTED IN DIRECT MODE SHOWN.

**NOTES:**

- WARNING: SUBSTITUTION WITH UNSPECIFIED COMPONENTS MAY IMPAIR INTRINSIC SAFETY.
  - MODEL -S2 TRANSUCERS ARE RATED:
    - INTRINSICALLY SAFE FOR CL I, II, DIV 1, GROUPS A, B, C, D, E, F, G
    - NON-INCENDIVE FOR CL I, DIV 2, GROUPS A, B, C, D
    - SUITABLE FOR CL II, DIV 2, GROUPS E, F, G
  - STANDARD MODEL 1010WX-S2 FLOW COMPUTERS ARE RATED:
    - CLASS 1, ZONE 1, AEX d [ic] IIB T5
    - EXPLOSION PROOF WITH I. S. OUTPUTS FOR CL I, II, GROUPS C, D, E, F, G
    - NON-INCENDIVE WITH N. I. OUTPUTS FOR CL I, DIV 2, GROUPS A, B, C, D
    - SUITABLE FOR CL II, DIV 2, GROUPS E, F, G
  - MODEL 1010WX-S2 FLOW COMPUTERS WITH "CS" ENCLOSURE CODE ARE RATED:
    - CLASS 1, ZONE 1, AEX d [ic] IIB+H2 T5
    - EXPLOSION PROOF WITH I. S. OUTPUTS FOR CL I, II, GROUPS B, C, D, E, F, G
    - NON-INCENDIVE WITH N. I. OUTPUTS FOR CL I, DIV 2, GROUPS A, B, C, D
    - SUITABLE FOR CL II, DIV 2, GROUPS E, F, G
- USE 1010WX MANUALS FOR OPERATION AND MAINTENANCE INSTRUCTIONS.
- ANY COMBINATION OF OUTPUTS MAY BE USED.
- CIRCUITS 1, 2, AND 3 MUST BE IN SEPARATE CONDUIT.
- DATA/CONTROL SIGNAL CONNECTIONS ARE MADE ON 1010N-2\*, 1010N-5\*, 1010N-7\*, 1010M-8M AND 1015N-5M MODULES. INCLUDED MODULES VARY WITH FLOW COMPUTER MODEL. 1015N-5M IS ORDERED SEPARATELY.
- MODULE PART NUMBER SUFFIX (\*) MAY VARY DEPENDING ON FLOW COMPUTER MODEL.

**SIEMENS**  
Siemens Energy & Automation, Inc.  
Process Instrumentation Business Unit  
CoC Ultrasonic Flow - Hauppauge, Long Island, NY 11788

**CONNECTION DIAGRAM**  
AGENCY APPROVED FOR HAZARDOUS AREA USE  
1010WX-S2 SERIES FLOW COMPUTER

DR	H.J	DATE	9/17/04
CHK		DATE	
ENG		DATE	
PRD		DATE	
APPD		DATE	
CERTIFIED			
DATE			

DO NOT SCALE THIS DRAWING  
UNLESS OTHERWISE SPECIFIED:  
DIMENSIONS ARE IN INCHES  
TOLERANCES - ANGLES -  
FRACTIONS - DECIMALS -  
+/- .1/16 XX +/- .005 +/- .030\*

MATERIAL:  
FINISH:

SIZE	CODE IDENT NO.	REV.
C	21614	05
SCALE:	1010-443	
WT.		SHEET 1 OF 7

1

2

3

4

D

C

B

A

D

C

B

A

1 2 3 4

**HAZARDOUS LOCATION**  
SEE SHEET 1 FOR PERMITTED FLOW  
COMPUTER LOCATION AREA RATINGS

1010WX-S2 OR 1010MWX-S2 SERIES  
FLOW COMPUTER  
(NEMA 7 ENCLOSURE)

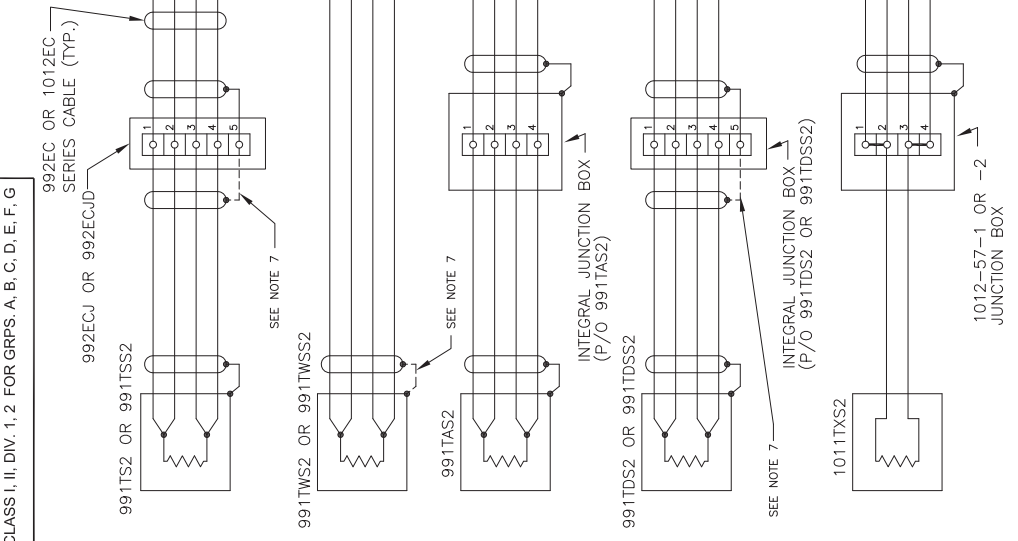
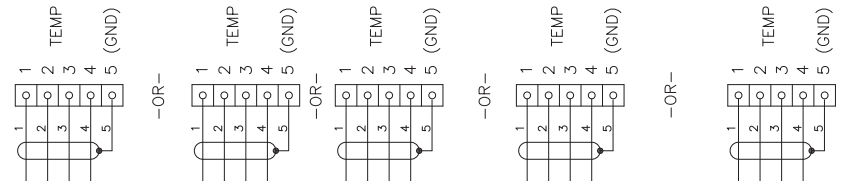

**HAZARDOUS LOCATION**  
CLASS I, II, DIV. 1, 2 FOR GRPS. A, B, C, D, E, F, G

<b>SIEMENS</b> Siemens Energy & Automation, Inc. Process Instrumentation Business Unit CoC Ultrasonic Flow - Hauppauge, Long Island, NY 11788		<b>CONNECTION DIAGRAM</b> AGENCY APPROVED FOR HAZARDOUS AREA USE 1010WX-S2 SERIES FLOW COMPUTER	
DO NOT SCALE THIS DRAWING UNLESS OTHERWISE SPECIFIED: DIMENSIONS ARE IN INCHES TOLERANCES ON- FRACTIONS- DECIMALS- ANGLES- +/- 1/16 XX+/-0.01 +/-0.30 XXX+/-0.005	CONTROLLED DRAWING CHANGES TO THIS DRAWING REQUIRE DESIGN/PAGE/APPD APPROVAL DR H, J DATE 3/30/05 CHK DATE ENG DATE PRD DATE APPD DATE CERTIFIED DATE	SIZE CODE IDENT NO. <b>C 21614</b> 1010-443	REV. <b>05</b>
NOTES: 7. INDICATED SHIELD CONNECTIONS ARE OPTIONAL AND DO NOT AFFECT SAFETY.		SCALE: NONE WT.	SHEET 2 OF 7



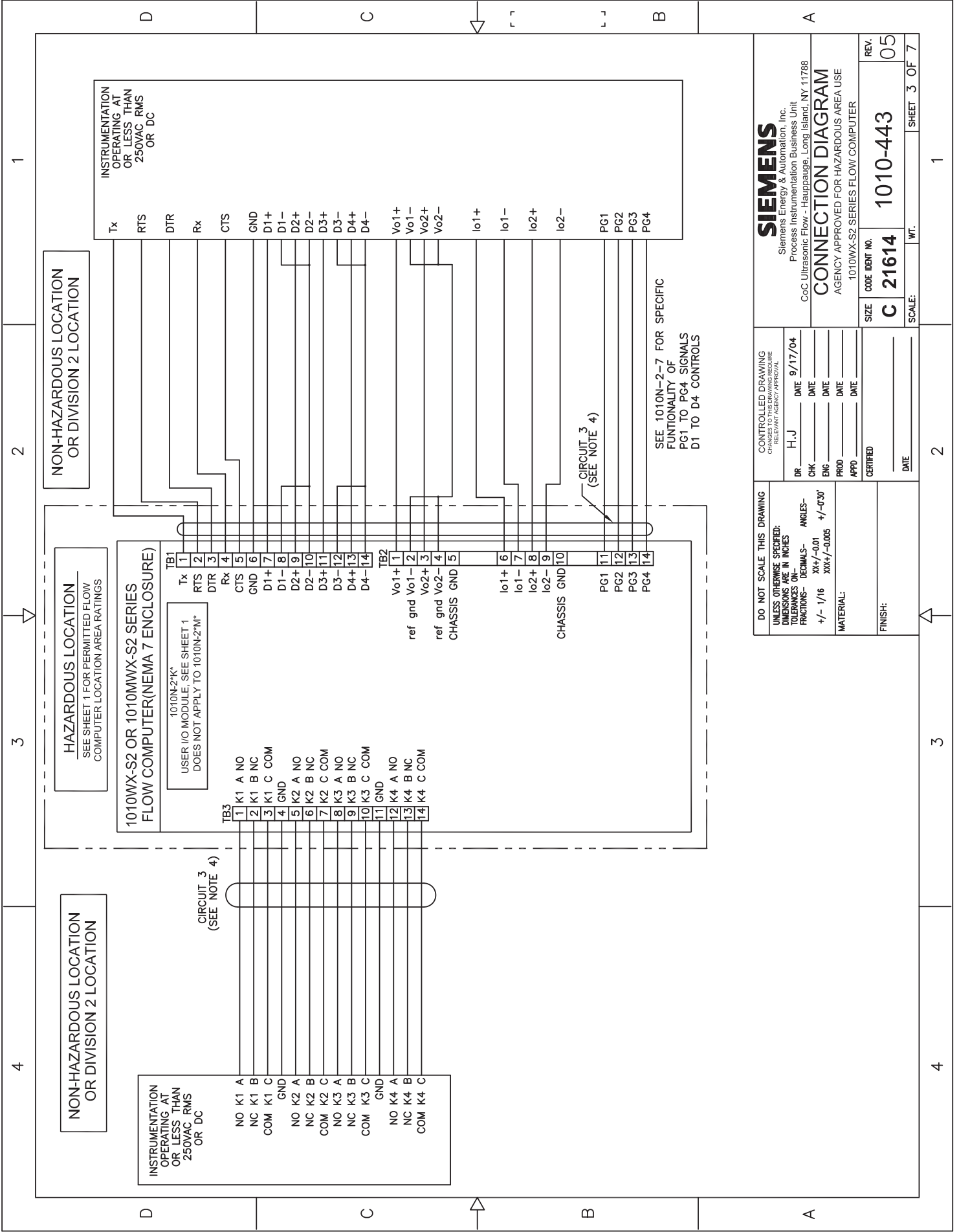

INSTRUMENTATION OPERATING AT OR LESS THAN 250VAC RMS OR DC

NON-HAZARDOUS LOCATION OR DIVISION 2 LOCATION

HAZARDOUS LOCATION  
SEE SHEET 1 FOR PERMITTED FLOW COMPUTER LOCATION AREA RATINGS

1010WX-S2 OR 1010MWX-S2 SERIES FLOW COMPUTER (NEMA 7 ENCLOSURE)

1010N-2-K\* USER I/O MODULE, SEE SHEET 1 DOES NOT APPLY TO 1010N-2-M\*

- TB3
- 1 K1 A NO
  - 2 K1 B NC
  - 3 K1 C COM
  - 4 GND
  - 5 K2 A NO
  - 6 K2 B NC
  - 7 K2 C COM
  - 8 K3 A NO
  - 9 K3 B NC
  - 10 K3 C COM
  - 11 GND
  - 12 K4 A NO
  - 13 K4 B NC
  - 14 K4 C COM

CIRCUIT 3 (SEE NOTE 4)

INSTRUMENTATION OPERATING AT OR LESS THAN 250VAC RMS OR DC

- NO K1 A
- NC K1 B
- COM K1 C
- GND
- NO K2 A
- NC K2 B
- COM K2 C
- NO K3 A
- NC K3 B
- COM K3 C
- GND
- NO K4 A
- NC K4 B
- COM K4 C

Tx

RTS

DTR

Rx

CTS

GND

D1+

D1-

D2+

D2-

D3+

D3-

D4+

D4-

Vo1+

Vo1-

Vo2+

Vo2-

io1+

io1-

io2+

io2-

PG1

PG2

PG3

PG4

CIRCUIT 3 (SEE NOTE 4)

SEE 1010N-2-7 FOR SPECIFIC FUNCTIONALITY OF PG1 TO PG4 SIGNALS D1 TO D4 CONTROLS

**SIEMENS**  
Siemens Energy & Automation, Inc.  
Process Instrumentation Business Unit  
CoC Ultrasonic Flow - Hauppauge, Long Island, NY 11788

**CONNECTION DIAGRAM**  
AGENCY APPROVED FOR HAZARDOUS AREA USE  
1010WX-S2 SERIES FLOW COMPUTER

SIZE: **C 21614** CODE IDENT NO. **1010-443** REV. **05**  
SCALE: \_\_\_\_\_ WT. \_\_\_\_\_ SHEET **3** OF **7**

DO NOT SCALE THIS DRAWING  
UNLESS OTHERWISE SPECIFIED:  
DIMENSIONS ARE IN INCHES  
FRACTIONS- DECIMALS- ANGLES-  
+/- 1/16 XX +/- 0.01 +/- 0.30  
XXX +/- 0.005

CONTROLLED DRAWING  
CHANGES TO THIS DRAWING REQUIRE RELEVANT AGENCY APPROVAL

DR: H.J. DATE: 9/17/04  
CHK: \_\_\_\_\_ DATE: \_\_\_\_\_  
ENG: \_\_\_\_\_ DATE: \_\_\_\_\_  
PRD: \_\_\_\_\_ DATE: \_\_\_\_\_  
APP: \_\_\_\_\_ DATE: \_\_\_\_\_  
CERTIFIED: \_\_\_\_\_  
DATE: \_\_\_\_\_



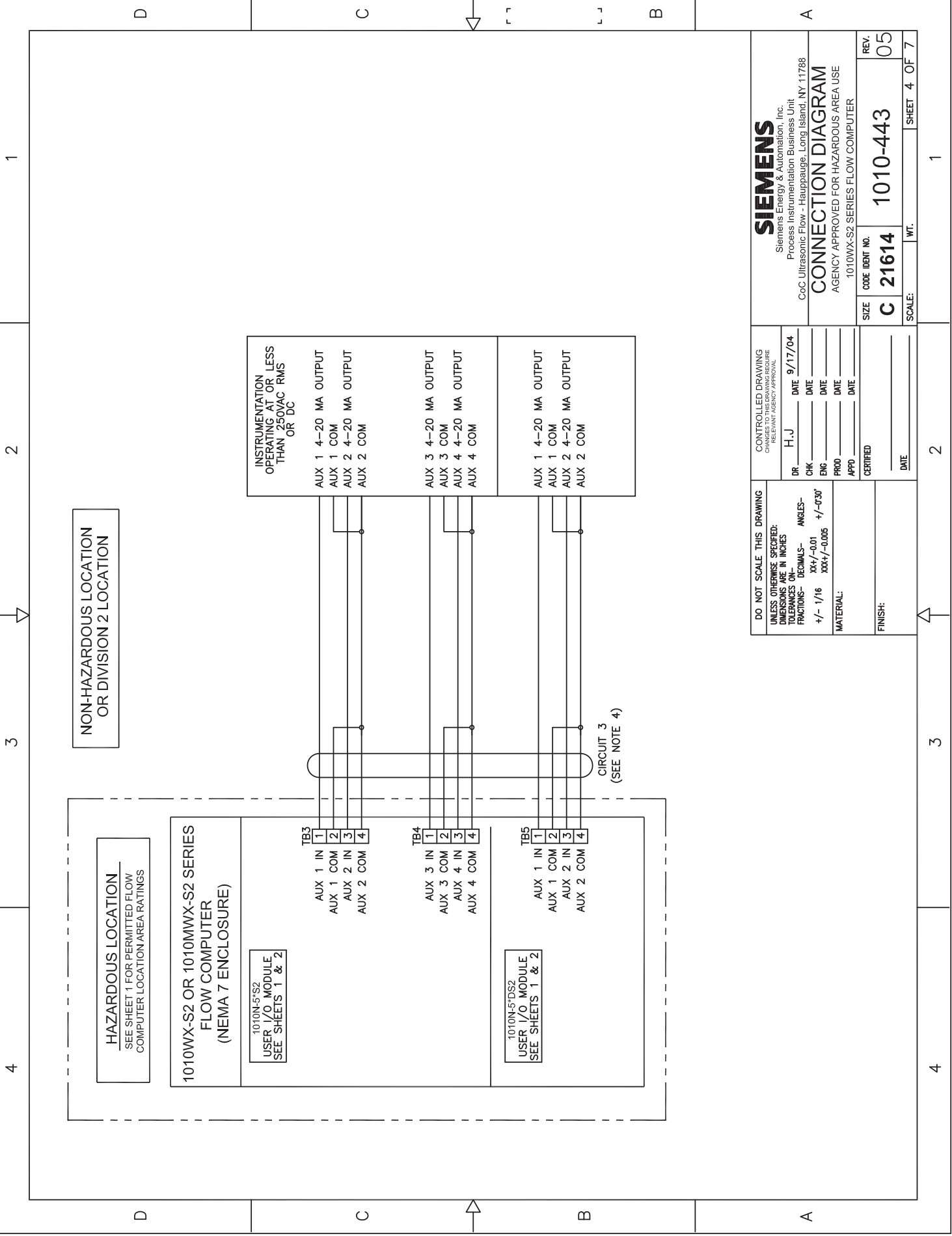

<p><b>DO NOT SCALE THIS DRAWING</b> UNLESS OTHERWISE SPECIFIED: DIMENSIONS ARE IN INCHES FRACTIONS- DECIMALS- ANGLES- +/- 1/16    XX +/- .001    +/- 0°30'              XXX +/- .0005    +/ - 0°30'</p> <p>MATERIAL: FINISH:</p>	<p><b>CONTROLLED DRAWING</b> CHANGES TO THIS DRAWING REQUIRE RELEVANT AGENCY APPROVAL</p> <p>DR: H.J.    DATE: 9/17/04 CHK:       DATE:       ENG:       DATE:       PRD:       DATE:       APP:       DATE:       CERTIFIED:       DATE:      </p>	<p><b>SIEMENS</b> Siemens Energy &amp; Automation, Inc. Process Instrumentation Business Unit CoC Ultrasonic Flow - Hauppauge, Long Island, NY 11788</p> <p><b>CONNECTION DIAGRAM</b> AGENCY APPROVED FOR HAZARDOUS AREA USE 1010MWX-S2 SERIES FLOW COMPUTER</p>	<p>SIZE: <b>C</b>    CODE IDENT NO.: <b>21614</b>    REV.: <b>05</b> <b>1010-443</b></p> <p>SCALE:       WT.    SHEET 4 OF 7</p>
--	---	--	--



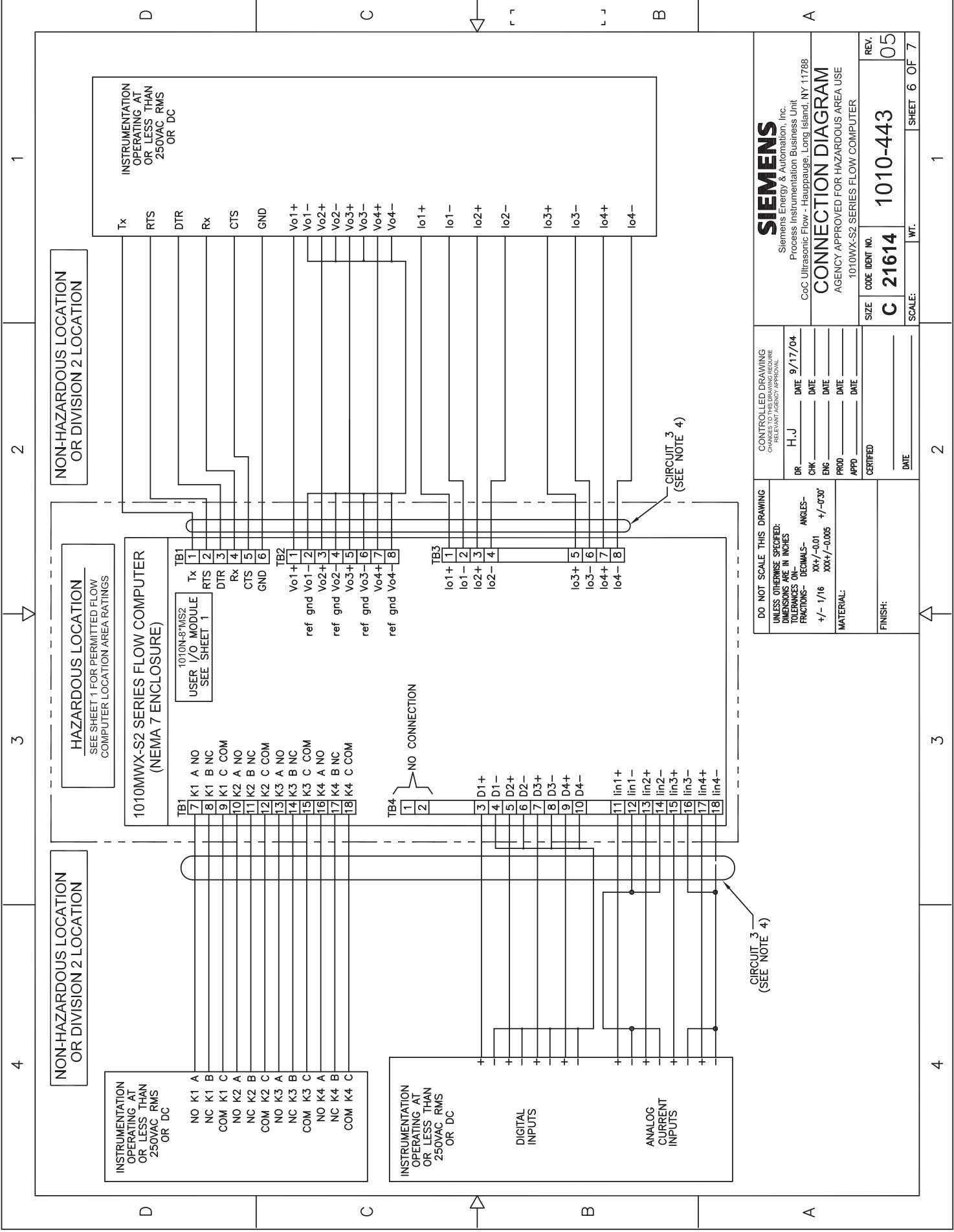

NON-HAZARDOUS LOCATION  
OR DIVISION 2 LOCATION

HAZARDOUS LOCATION  
SEE SHEET 1 FOR PERMITTED FLOW  
COMPUTER LOCATION AREA RATINGS

NON-HAZARDOUS LOCATION  
OR DIVISION 2 LOCATION

INSTRUMENTATION  
OPERATING AT  
OR LESS THAN  
250VAC RMS  
OR DC

1010MWX-S2 SERIES FLOW COMPUTER  
(NEMA 7 ENCLOSURE)

INSTRUMENTATION  
OPERATING AT  
OR LESS THAN  
250VAC RMS  
OR DC

INSTRUMENTATION  
OPERATING AT  
OR LESS THAN  
250VAC RMS  
OR DC

1010N-8\*MS2  
USER I/O MODULE  
SEE SHEET 1

- TB1 7 K1 A NO
- 8 K1 B NC
- 9 K1 C COM
- 10 K2 A NO
- 11 K2 B NC
- 12 K2 C COM
- 13 K3 A NO
- 14 K3 B NC
- 15 K3 C COM
- 16 K4 A NO
- 17 K4 B NC
- 18 K4 C COM

- TB1 Tx 1
- RTS 2
- DTR 3
- Rx 4
- CTS 5
- GND 6

- Tx
- RTS
- DTR
- Rx
- CTS
- GND

- Vo1+
- Vo1-
- Vo2+
- Vo2-
- Vo3+
- Vo3-
- Vo4+
- Vo4-

- lo1+
- lo1-
- lo2+
- lo2-
- lo3+
- lo3-
- lo4+
- lo4-

- ref grd
- ref grd
- ref grd
- ref grd

- TB2 Vo1+
- Vo1-
- Vo2+
- Vo2-
- Vo3+
- Vo3-
- Vo4+
- Vo4-

- TB3 lo1+
- lo1-
- lo2+
- lo2-
- lo3+
- lo3-
- lo4+
- lo4-

- TB4 1
- 2
- 3 D1+
- 4 D1-
- 5 D2+
- 6 D2-
- 7 D3+
- 8 D3-
- 9 D4+
- 10 D4-
- 11 lin1+
- 12 lin1-
- 13 lin2+
- 14 lin2-
- 15 lin3+
- 16 lin3-
- 17 lin4+
- 18 lin4-

- INSTRUMENTATION  
OPERATING AT  
OR LESS THAN  
250VAC RMS  
OR DC
- DIGITAL  
INPUTS
- ANALOG  
CURRENT  
INPUTS

CIRCUIT 3  
(SEE NOTE 4)

CIRCUIT 3  
(SEE NOTE 4)

NO CONNECTION

<p><b>SIEMENS</b> Siemens Energy &amp; Automation, Inc. Process Instrumentation Business Unit CoC Ultrasonic Flow - Hauppauge, Long Island, NY 11788</p>		<p><b>CONNECTION DIAGRAM</b> AGENCY APPROVED FOR HAZARDOUS AREA USE 1010MWX-S2 SERIES FLOW COMPUTER</p>	
<p>CONTROLLED DRAWING CHANGES TO THIS DRAWING REQUIRE RELEVANT AGENCY APPROVAL</p>	<p>DR H.J.</p>	<p>DATE 9/17/04</p>	<p>REV. 05</p>
<p>UNLESS OTHERWISE SPECIFIED: DIMENSIONS ARE IN INCHES FRACTIONS- DECIMALS- ANGLES- +/- 1/16 XX/-0.01 +/--0.30 XXX/-0.005</p>	<p>CHK _____</p>	<p>DATE _____</p>	<p>SCALE: 1010-443</p>
<p>MATERIAL:</p>	<p>ENG _____</p>	<p>DATE _____</p>	<p>SIZE C</p>
<p>FINISH:</p>	<p>PRD _____</p>	<p>DATE _____</p>	<p>CODE IDENT NO. 21614</p>
<p>DO NOT SCALE THIS DRAWING</p>	<p>APPD _____</p>	<p>DATE _____</p>	<p>WT. _____</p>
<p>CERTIFIED</p>	<p>DATE _____</p>	<p>DATE _____</p>	<p>SHEET 6 OF 7</p>

1

2

3

4

1

2

3

4

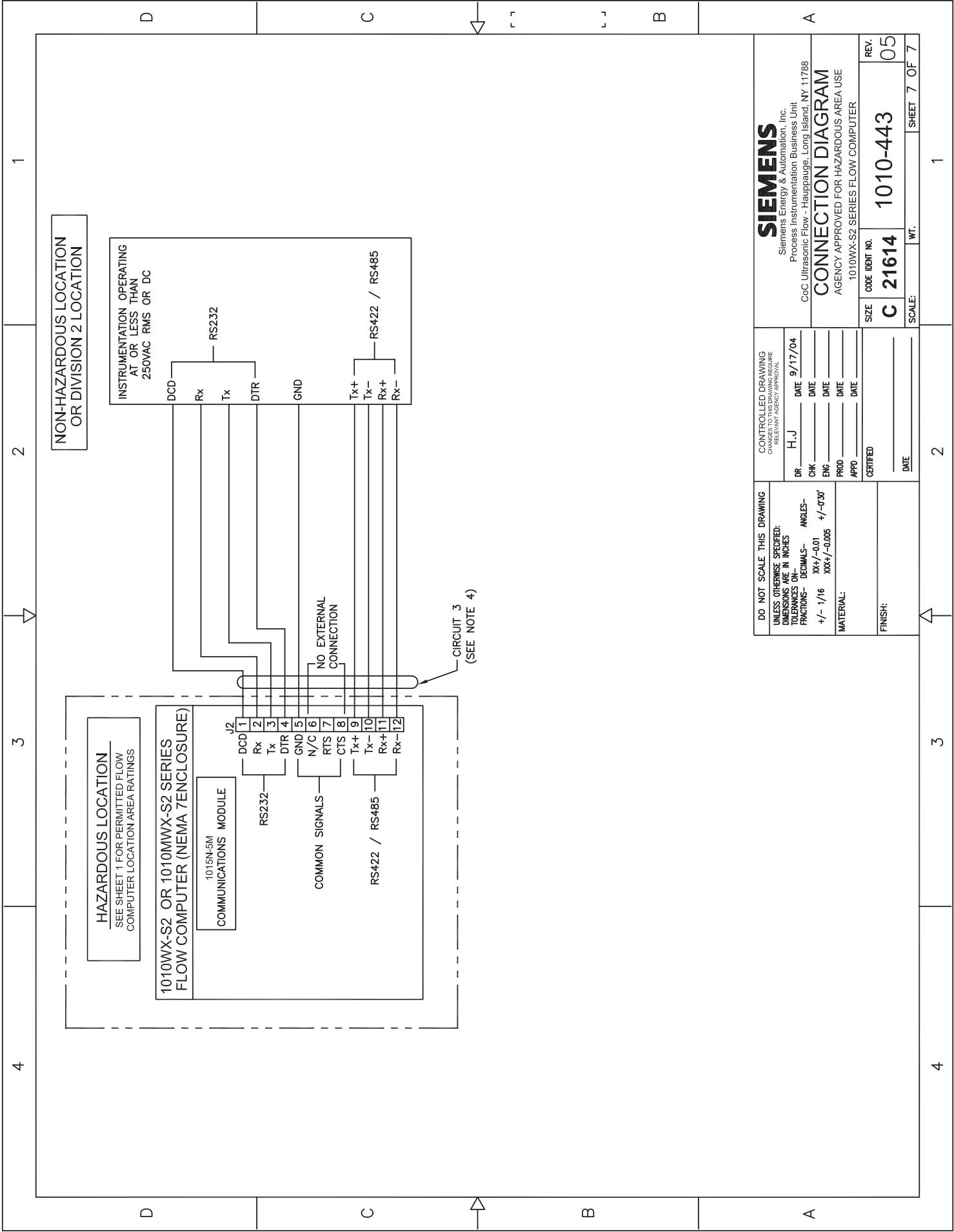

<b>DO NOT SCALE THIS DRAWING</b> UNLESS OTHERWISE SPECIFIED: DIMENSIONS ARE IN INCHES TOLERANCES - DECIMALS - ANGLES - FRACTIONS - DECIMALS - +/- 1/16 XX +/- 0.01 +/- 0.30 XXX +/- 0.005	<b>CONTROLLED DRAWING</b> CHANGES TO THIS DRAWING REQUIRE RELEVANT AGENCY APPROVAL	
	DR H.J CHK _____ ENG _____ PRD _____ APPD _____ CERTIFIED _____ DATE _____	DATE 9/17/04 DATE _____ DATE _____ DATE _____
<b>HAZARDOUS LOCATION</b> SEE SHEET 1 FOR PERMITTED FLOW COMPUTER LOCATION AREA RATINGS	<b>SIEMENS</b> Siemens Energy & Automation, Inc. Process Instrumentation Business Unit CoC Ultrasonic Flow - Hauppauge, Long Island, NY 11788	
	<b>CONNECTION DIAGRAM</b> AGENCY APPROVED FOR HAZARDOUS AREA USE 1010WX-S2 SERIES FLOW COMPUTER	
MATERIAL: FINISH:	SIZE C CODE IDENT NO. 21614 SCALE:	REV. 05 SHEET 7 OF 7

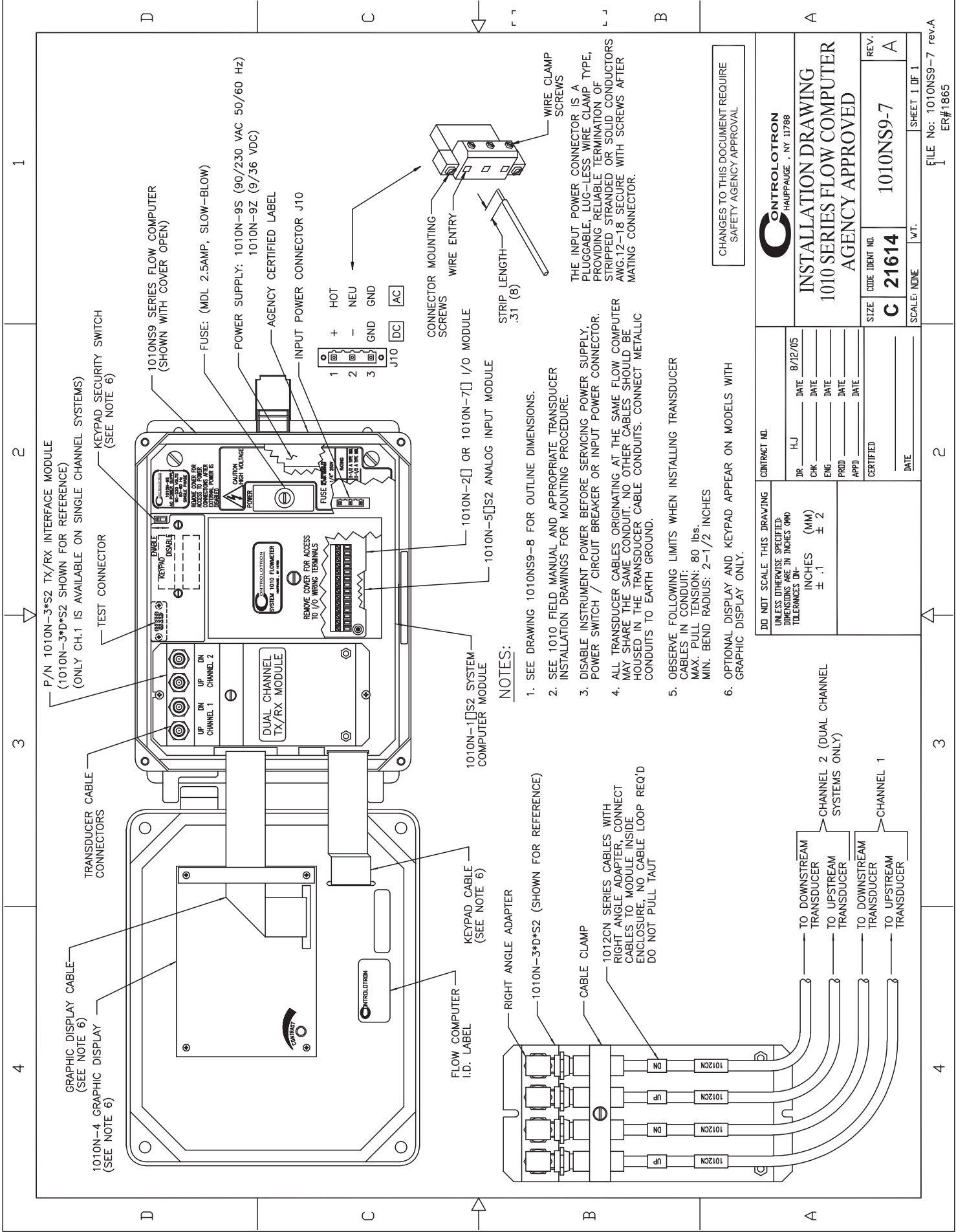

CHANGES TO THIS DOCUMENT REQUIRE SAFETY AGENCY APPROVAL

<b>CONTROLTRON</b> HAUPPAUGE, NY 11788	
<b>INSTALLATION DRAWING</b> <b>1010 SERIES FLOW COMPUTER</b> <b>AGENCY APPROVED</b>	
SIZE	CODE IDENT. NO.
<b>C</b>	<b>21614</b>
SCALE: NONE	WT.
	<b>1010NS9-7</b>
REV.	A
SHEET 1 OF 1	

DO NOT SCALE THIS DRAWING UNLESS OTHERWISE SPECIFIED. DIMENSIONS ARE IN INCHES (MM) TOLERANCES UNLESS OTHERWISE SPECIFIED:	CONTRACT NO.
INCHES ± .1	DATE 8/12/05
MILLIMETERS ± .2	DATE
	DATE
	DATE
	DATE
	DATE
	DATE
	DATE
	DATE
	DATE

- NOTES:**
- SEE DRAWING 1010NS9-8 FOR OUTLINE DIMENSIONS.
  - SEE 1010 FIELD MANUAL AND APPROPRIATE TRANSDUCER INSTALLATION DRAWINGS FOR MOUNTING PROCEDURE.
  - DISABLE INSTRUMENT POWER BEFORE SERVICING POWER SUPPLY, POWER SWITCH / CIRCUIT BREAKER OR INPUT POWER CONNECTOR.
  - ALL TRANSDUCER CABLES ORIGINATING AT THE SAME FLOW COMPUTER MAY SHARE THE SAME CONDUIT. NO OTHER CABLES SHOULD BE HOUSED IN THE TRANSDUCER CABLE CONDUITS. CONNECT METALLIC CONDUITS TO EARTH GROUND.
  - OBSERVE FOLLOWING LIMITS WHEN INSTALLING TRANSDUCER CABLES IN CONDUIT:  
MAX. PULL TENSION: 80 lbs.  
MIN. BEND RADIUS: 2-1/2 INCHES
  - OPTIONAL DISPLAY AND KEYPAD APPEAR ON MODELS WITH GRAPHIC DISPLAY ONLY.

1012CN SERIES CABLES WITH RIGHT ANGLE ADAPTER. CONNECT CABLES TO MODULE INSIDE ENCLOSURE; NO CABLE LOOP REQ'D DO NOT PULL TAUT

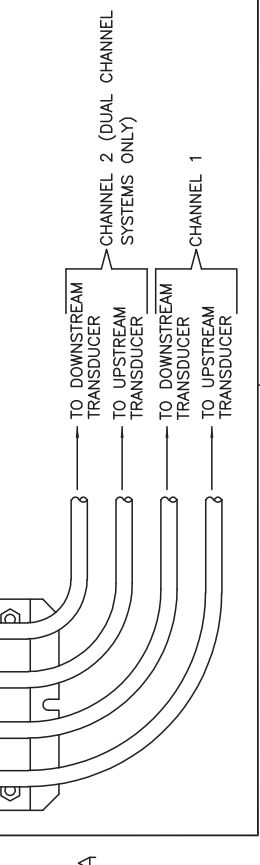









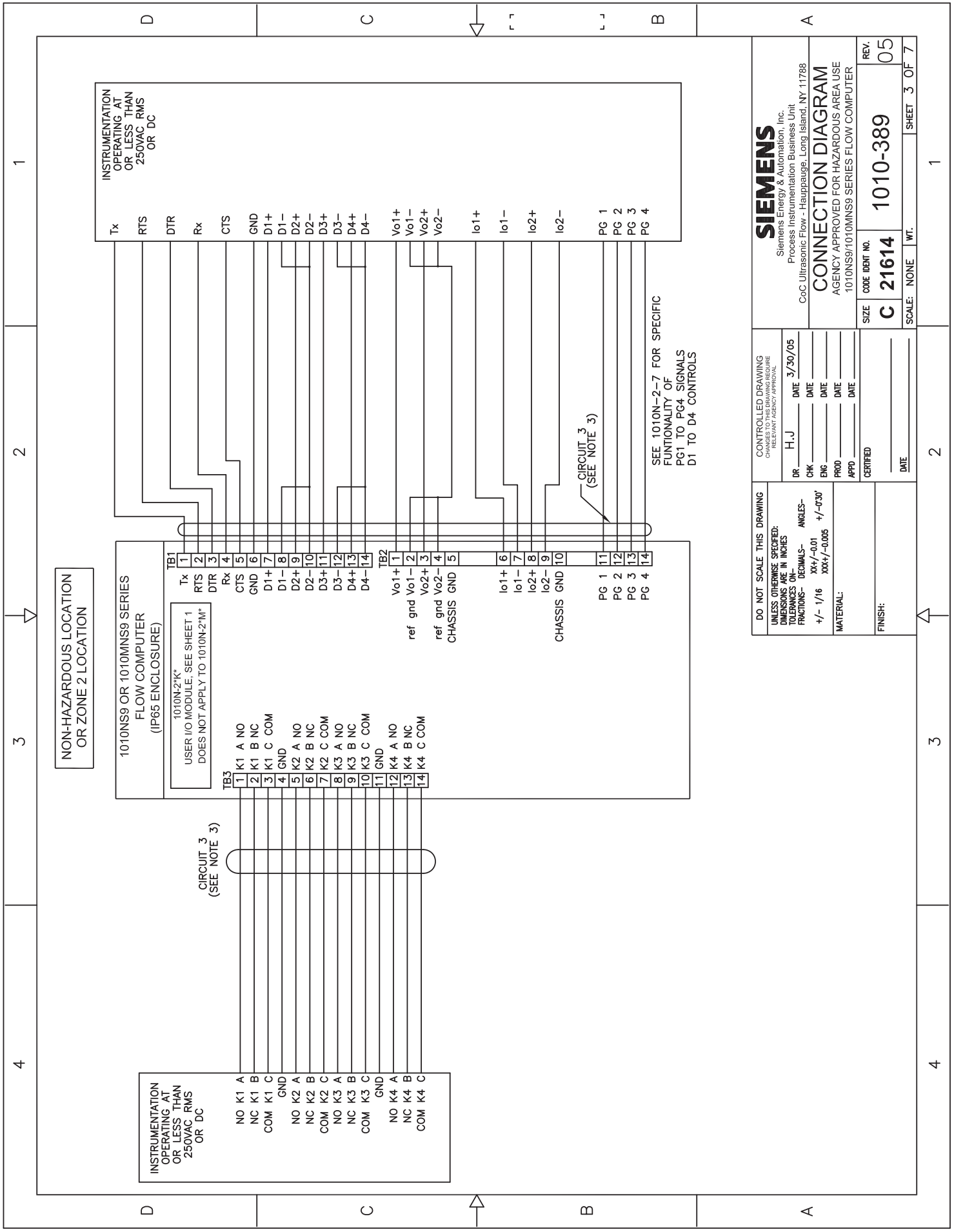

NON-HAZARDOUS LOCATION  
OR ZONE 2 LOCATION

1010NS9 OR 1010MNS9 SERIES  
FLOW COMPUTER  
(IP65 ENCLOSURE)

TB1  
1 Tx  
2 RTS  
3 DTR  
4 Rx  
5 CTS  
6 GND  
7 D1+  
8 D1-  
9 D2+  
10 D2-  
11 D3+  
12 D3-  
13 D4+  
14 D4-  
TB2  
1 Vo1+  
2 Vo1-  
3 Vo2+  
4 Vo2-  
5 CHASSIS GND  
6 lo1+  
7 lo1-  
8 lo2+  
9 lo2-  
10 CHASSIS GND  
11 PG 1  
12 PG 2  
13 PG 3  
14 PG 4

1010N-2"K"  
USER I/O MODULE - SEE SHEET 1  
DOES NOT APPLY TO 1010N-2"K"

TB3  
1 K1 A NO  
2 K1 B NC  
3 K1 C COM  
4 GND  
5 K2 A NO  
6 K2 B NC  
7 K2 C COM  
8 K3 A NO  
9 K3 B NC  
10 K3 C COM  
11 GND  
12 K4 A NO  
13 K4 B NC  
14 K4 C COM

INSTRUMENTATION  
OPERATING AT  
OR LESS THAN  
250VAC RMS  
OR DC

Tx  
RTS  
DTR  
Rx  
CTS  
GND  
D1+  
D1-  
D2+  
D2-  
D3+  
D3-  
D4+  
D4-  
Vo1+  
Vo1-  
Vo2+  
Vo2-  
lo1+  
lo1-  
lo2+  
lo2-  
PG 1  
PG 2  
PG 3  
PG 4

INSTRUMENTATION  
OPERATING AT  
OR LESS THAN  
250VAC RMS  
OR DC

NO K1 A  
NC K1 B  
COM K1 C  
GND  
NO K2 A  
NC K2 B  
COM K2 C  
NO K3 A  
NC K3 B  
COM K3 C  
GND  
NO K4 A  
NC K4 B  
COM K4 C

SEE 1010N-2-7 FOR SPECIFIC  
FUNCTIONALITY OF  
PG1 TO PG4 SIGNALS  
D1 TO D4 CONTROLS

CIRCUIT 3  
(SEE NOTE 3)

<b>SIEMENS</b> Siemens Energy & Automation, Inc. Process Instrumentation Business Unit CoC, Ultrasonic Flow - Hauppauge, Long Island, NY 11788		<b>CONNECTION DIAGRAM</b> AGENCY APPROVED FOR HAZARDOUS AREA USE 1010NS9/1010MNS9 SERIES FLOW COMPUTER	
DO NOT SCALE THIS DRAWING UNLESS OTHERWISE SPECIFIED: DIMENSIONS ARE IN INCHES TOLERANCES - DECIMALS - ANGLES - FRACTIONS - DECIMALS - +/- 1/16 XX +/- 0.01 +/- 0.30 MATERIAL: FINISH:	CONTROLLED DRAWING CHANGES TO THIS DRAWING REQUIRE RELEVANT AGENCY APPROVAL DR H, J DATE 3/30/05 CHK DATE ENG DATE PROD DATE APPD DATE CERTIFIED DATE	SIZE <b>C 21614</b>	CODE IDENT NO. <b>1010-389</b>
AGENCY APPROVED FOR HAZARDOUS AREA USE 1010NS9/1010MNS9 SERIES FLOW COMPUTER		SCALE: NONE WT.	REV. <b>05</b> SHEET 3 OF 7

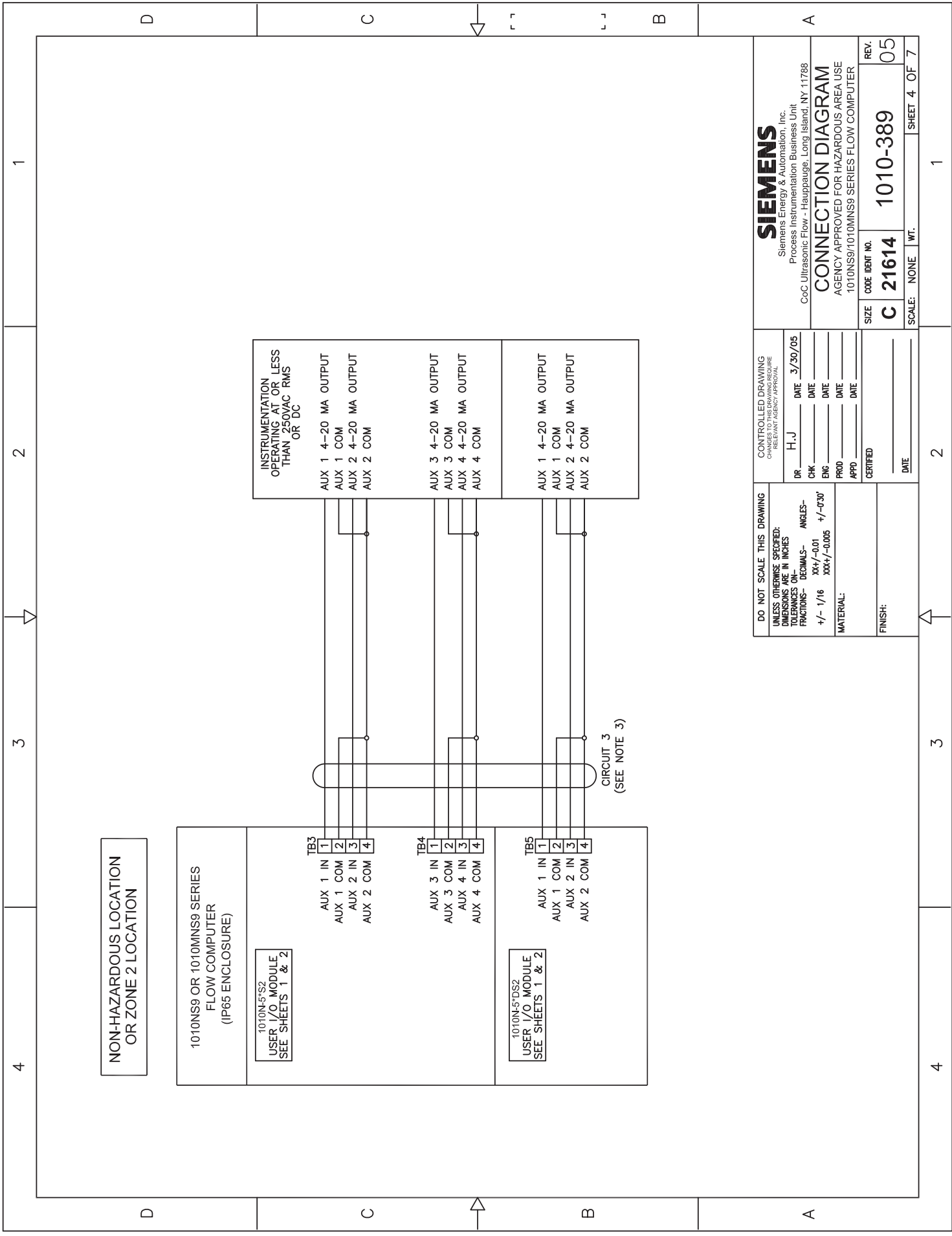

NON-HAZARDOUS LOCATION  
OR ZONE 2 LOCATION

1010NS9 OR 1010MINS9 SERIES  
FLOW COMPUTER  
(IP65 ENCLOSURE)

1010N-5\*52  
USER I/O MODULE  
SEE SHEETS 1 & 2

TB3  
AUX 1 IN 1  
AUX 1 COM 2  
AUX 2 IN 3  
AUX 2 COM 4

TB4  
AUX 3 IN 1  
AUX 3 COM 2  
AUX 4 IN 3  
AUX 4 COM 4

TB5  
AUX 1 IN 1  
AUX 1 COM 2  
AUX 2 IN 3  
AUX 2 COM 4

INSTRUMENTATION  
OPERATING AT OR LESS  
THAN 250VAC RMS  
OR DC

AUX 1 4-20 MA OUTPUT  
AUX 1 COM  
AUX 2 4-20 MA OUTPUT  
AUX 2 COM

AUX 3 4-20 MA OUTPUT  
AUX 3 COM  
AUX 4 4-20 MA OUTPUT  
AUX 4 COM

AUX 1 4-20 MA OUTPUT  
AUX 1 COM  
AUX 2 4-20 MA OUTPUT  
AUX 2 COM

CIRCUIT 3  
(SEE NOTE 3)

DO NOT SCALE THIS DRAWING UNLESS OTHERWISE SPECIFIED: DIMENSIONS ARE IN INCHES TOLERANCES ON— FRACTIONS— DECIMALS— ANGLES— +/- 1/16 XX+/-0.01 +/-0.30° XXX+/-0.005		CONTROLLED DRAWING CHECKED BY: H.J. DATE: 3/30/05 DESIGNED BY: H.J. DATE: _____ APPROVED BY: _____ DATE: _____ CERTIFIED: _____ DATE: _____	
MATERIAL:		AGENCY APPROVED FOR HAZARDOUS AREA USE 1010NS9/1010MINS9 SERIES FLOW COMPUTER	
FINISH:		SIZE: C	REV. 05
		CODE IDENT NO. 21614	1010-389
		SCALE: NONE	WT. SHEET 4 OF 7

**SIEMENS**  
Siemens Energy & Automation, Inc.  
Process Instrumentation Business Unit  
CoC Ultrasonic Flow - Hauppauge, Long Island, NY 11788

**CONNECTION DIAGRAM**  
AGENCY APPROVED FOR HAZARDOUS AREA USE  
1010NS9/1010MINS9 SERIES FLOW COMPUTER

DATE: \_\_\_\_\_  
CERTIFIED: \_\_\_\_\_  
DATE: \_\_\_\_\_



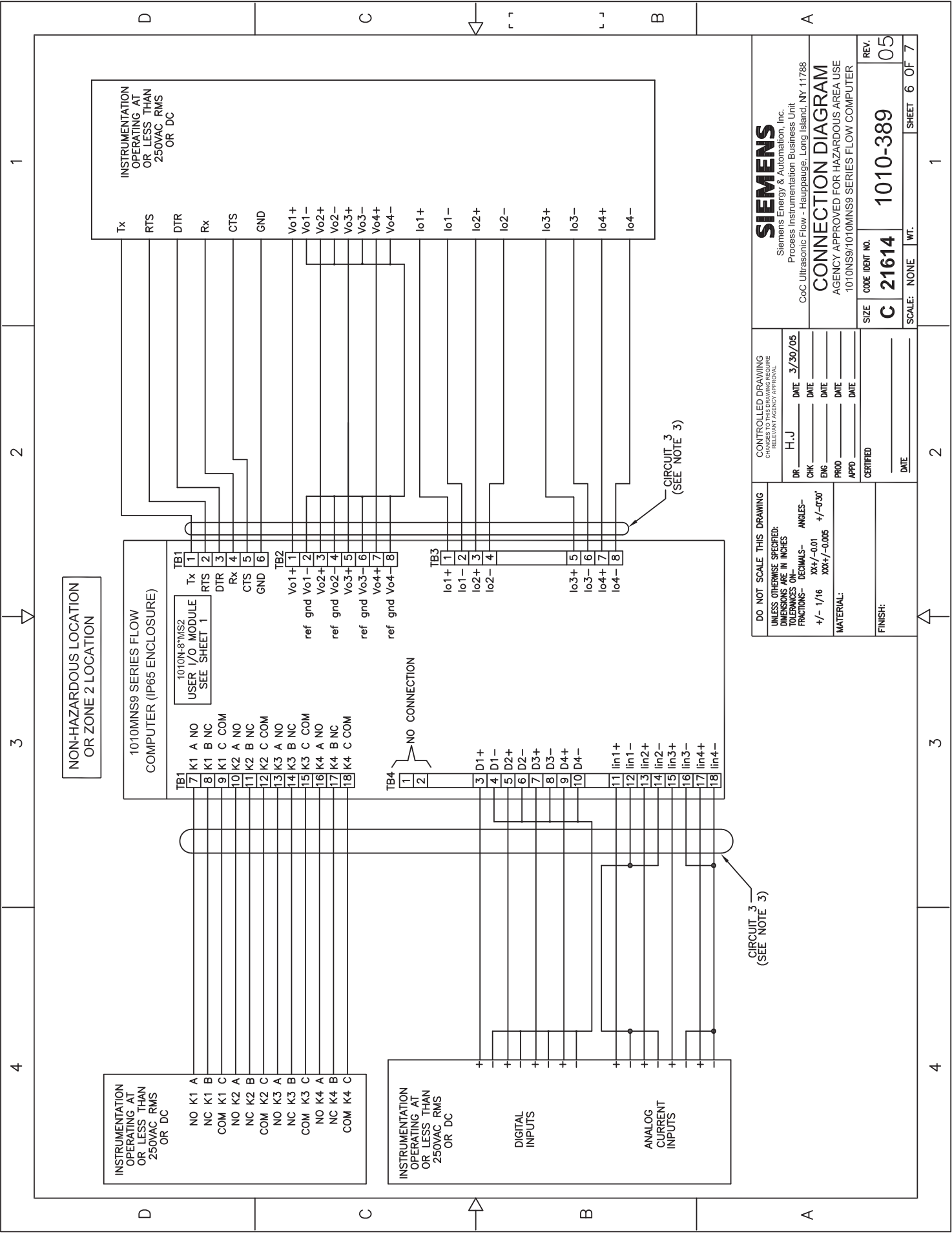

<b>SIEMENS</b> Siemens Energy & Automation, Inc. Process Instrumentation Business Unit CoC Ultrasonic Flow - Hauppauge, Long Island, NY 11788		<b>CONTROLLED DRAWING</b> CHANGES TO THIS DRAWING REQUIRE RELEVANT AGENCY APPROVAL DR: H.J. DATE: 3/30/05 CHK: DATE: DATE: DATE: DATE: DATE: DATE:	
<b>CONNECTION DIAGRAM</b> AGENCY APPROVED FOR HAZARDOUS AREA USE 1010MNS9/1010MNS9 SERIES FLOW COMPUTER		SIZE: <b>C</b> CODE IDENT NO.: <b>21614</b> REV.: <b>05</b> SCALE: NONE WT. SHEET 6 OF 7	

4 3 2 1

1 2 3 4

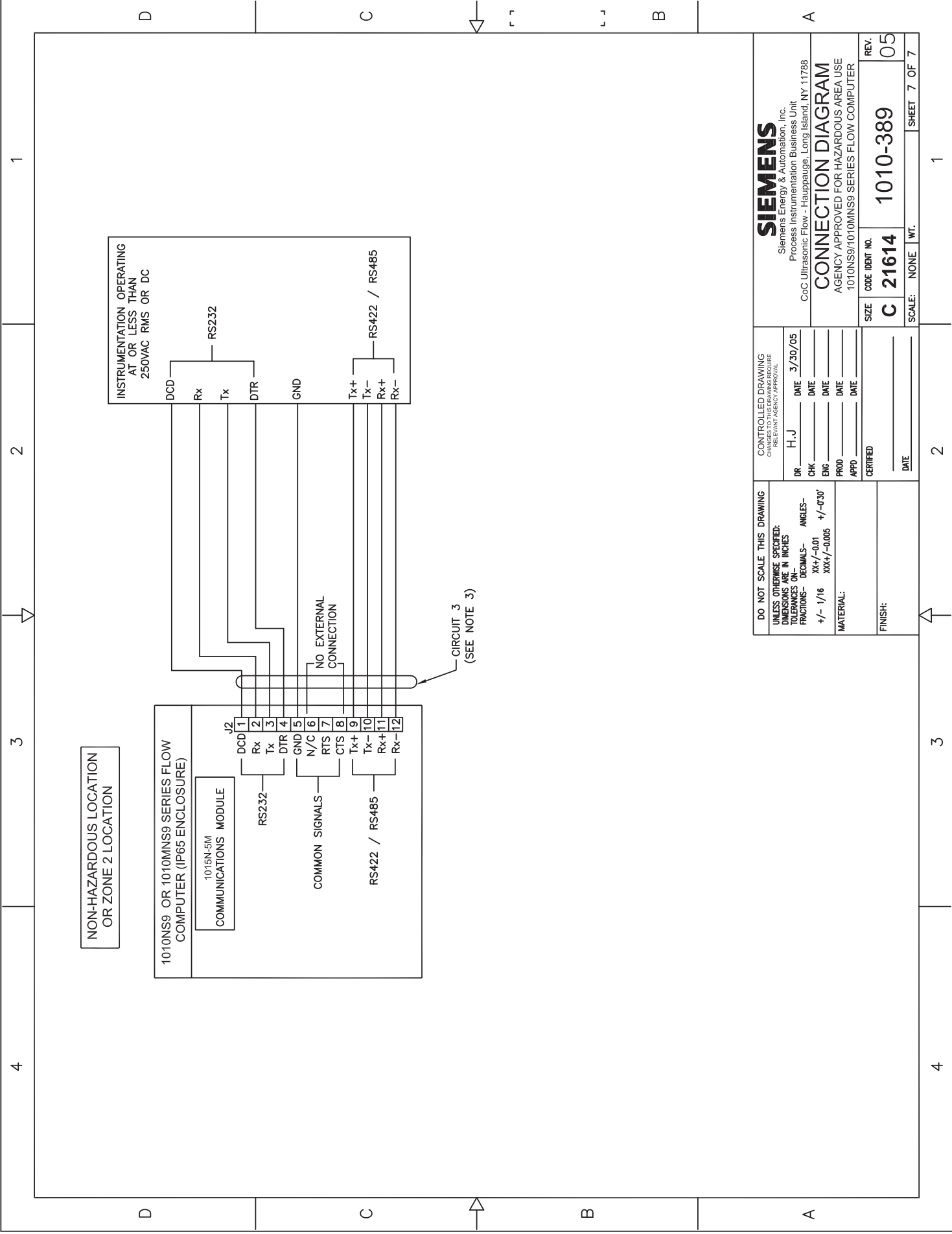

DO NOT SCALE THIS DRAWING UNLESS OTHERWISE SPECIFIED: DIMENSIONS IN INCHES TOLERANCES ON FRACTIONS- DECIMALS- ANGLES- XX +/- 0.01    XXX +/- 0.005    +/- 0.30° MATERIAL: FINISH:	CONTROLLED DRAWING CHANGES TO THIS DRAWING REQUIRE RELEVANT AGENCY APPROVAL		SIEMENS Siemens Energy & Automation, Inc. Process Instrumentation Business Unit CoC Ultrasonic Flow - Hauppauge, Long Island, NY 11788
	DR H, J	DATE 3/30/05	
	CHK	DATE	CONNECTION DIAGRAM AGENCY APPROVED FOR HAZARDOUS AREA USE 1010NS9/1010MNS9 SERIES FLOW COMPUTER
	ENG	DATE	
	PRD	DATE	
	APPD	DATE	
	CERTIFIED		REV. 05
	DATE		SIZE C 21614 1010-389
			SCALE: NONE WT.
			SHEET 7 OF 7

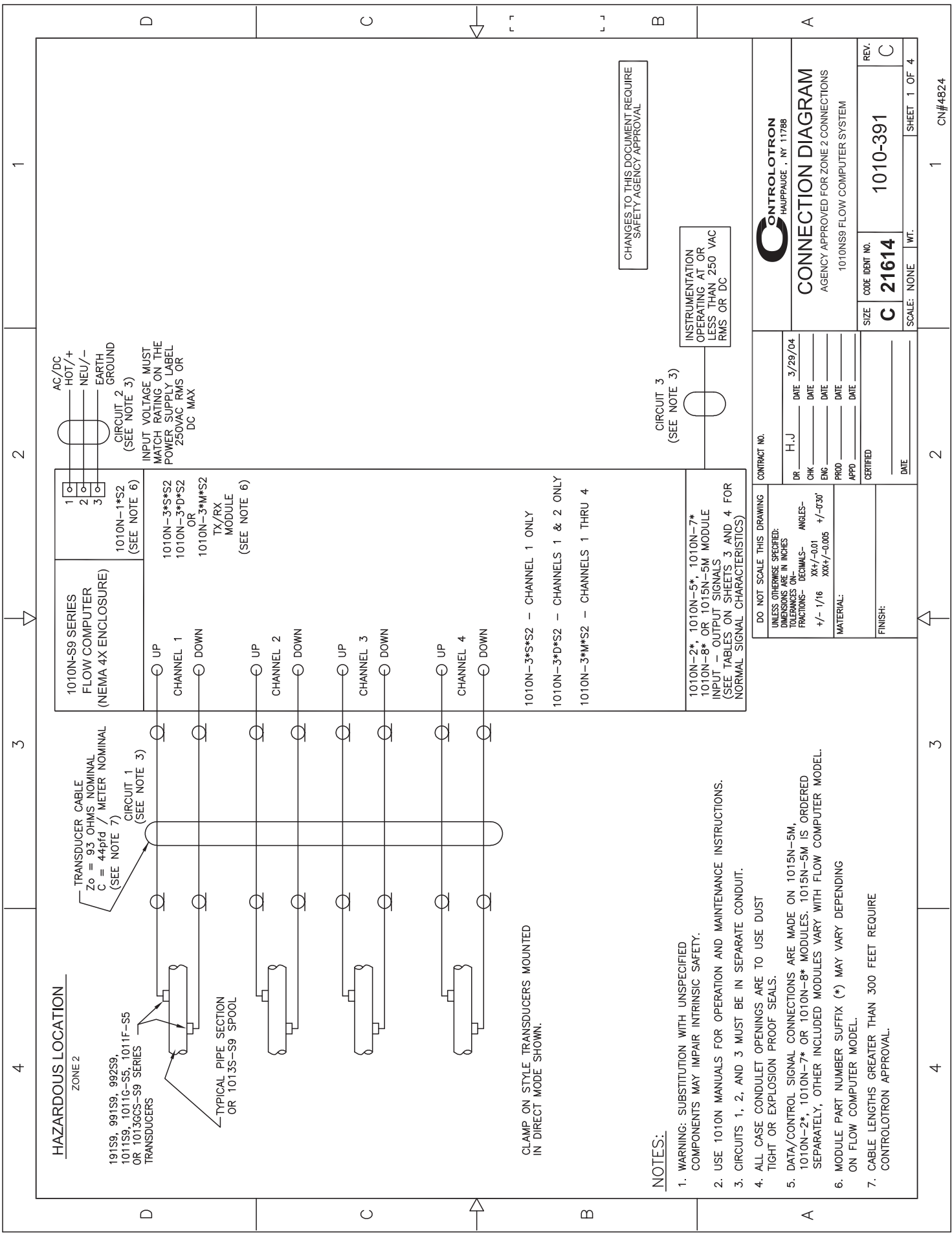

**HAZARDOUS LOCATION**

ZONE 2

191S9, 991S9, 992S9,  
1011S9, 1011G-S5, 1011F-S5  
OR 1013GCS-S9 SERIES  
TRANSDUCERS

TYPICAL PIPE SECTION  
OR 1013S-S9 SPOOL

TRANSducer CABLE  
 $Z_0 = 93$  OHMS NOMINAL  
 $C = 44pfd$  / METER NOMINAL  
(SEE NOTE 7)

CIRCUIT 1  
(SEE NOTE 3)

1010N-S9 SERIES  
FLOW COMPUTER  
(NEMA 4X ENCLOSURE)

1010N-1\*S2  
(SEE NOTE 6)

1010N-3\*S\*S2  
1010N-3\*D\*S2  
OR  
1010N-3\*M\*S2  
TX/RX  
MODULE  
(SEE NOTE 6)

UP

CHANNEL 1

DOWN

UP

CHANNEL 2

DOWN

UP

CHANNEL 3

DOWN

UP

CHANNEL 4

DOWN

1010N-3\*S\*S2 - CHANNEL 1 ONLY

1010N-3\*D\*S2 - CHANNELS 1 & 2 ONLY

1010N-3\*M\*S2 - CHANNELS 1 THRU 4

1010N-2\*, 1010N-5\*, 1010N-7\*  
1010N-8\* OR 1015N-5M MODULE  
INPUT - OUTPUT SIGNALS  
(SEE TABLES ON SHEETS 3 AND 4 FOR  
NORMAL SIGNAL CHARACTERISTICS)

CHANGES TO THIS DOCUMENT REQUIRE  
SAFETY AGENCY APPROVAL

CIRCUIT 3  
(SEE NOTE 3)

INSTRUMENTATION  
OPERATING AT OR  
LESS THAN 250 VAC  
RMS OR DC

**NOTES:**

1. WARNING: SUBSTITUTION WITH UNSPECIFIED COMPONENTS MAY IMPAIR INTRINSIC SAFETY.
2. USE 1010N MANUALS FOR OPERATION AND MAINTENANCE INSTRUCTIONS.
3. CIRCUITS 1, 2, AND 3 MUST BE IN SEPARATE CONDUIT.
4. ALL CASE CONDULET OPENINGS ARE TO USE DUST TIGHT OR EXPLOSION PROOF SEALS.
5. DATA/CONTROL SIGNAL CONNECTIONS ARE MADE ON 1015N-5M, 1010N-2\*, 1010N-7\* OR 1010N-8\* MODULES. 1015N-5M IS ORDERED SEPARATELY, OTHER INCLUDED MODULES VARY WITH FLOW COMPUTER MODEL.
6. MODULE PART NUMBER SUFFIX (\*) MAY VARY DEPENDING ON FLOW COMPUTER MODEL.
7. CABLE LENGTHS GREATER THAN 300 FEET REQUIRE CONTROLTRON APPROVAL.

CONTRACT NO.

DR	H, J	DATE	3/29/04
CHK		DATE	
ENG		DATE	
PRD		DATE	
APPD		DATE	
CERTIFIED		DATE	
DATE			

DO NOT SCALE THIS DRAWING

UNLESS OTHERWISE SPECIFIED:  
DIMENSIONS ARE IN INCHES  
FRACTIONS - DECIMALS - ANGLES -  
+/- 1/16 XX +/- .001 +/- .030  
XXX +/- .005

MATERIAL:

FINISH:



**CONNECTION DIAGRAM**

AGENCY APPROVED FOR ZONE 2 CONNECTIONS  
1010NS9 FLOW COMPUTER SYSTEM

SIZE	CODE IDENT NO.	REV.
C	21614	C
SCALE: NONE	WT.	SHEET 1 OF 4



**NORMAL SIGNAL CHARACTERISTICS**  
(SEE NOTES 5 & 6)

MODULE	LOCATION	FUNCTION	NORMAL VOLTAGE	CURRENT
1010N+2, 1010N+2K2 OR 1010N+2K3	TB1-1	Tx	to ±12 Vdc	4 mA
	TB1-2	RTS	to ±12 Vdc	4 mA
	TB1-3	DTR	to ±12 Vdc	4 mA
	TB1-4	Rx	to ±12 Vdc	4 mA
	TB1-5	CTS	to ±12 Vdc	4 mA
	TB1-6	GND	0 Vdc	20 mA
	TB1-7	D1+	0 to 5 Vdc	5 mA
	TB1-8	D1-	0 Vdc	5 mA
	TB1-9	D2+	0 to 5 Vdc	5 mA
	TB1-10	D2-	0 Vdc	5 mA
	TB1-11	D3+	0 to 5 Vdc	5 mA
	TB1-12	D3-	0 Vdc	5 mA
	TB1-13	D4+	0 to 5 Vdc	5 mA
	TB1-14	D4-	0 Vdc	5 mA
1010N+5DS2	TB2-1	Vo1+	0 - 10 Vdc	1 mA
	TB2-2	Vo2+	0 - 10 Vdc	1 mA
	TB2-3	Vo2-	0 Vdc	1 mA
	TB2-4	Vo3+	0 - 10 Vdc	1 mA
	TB2-5	Vo3-	0 Vdc	1 mA
	TB2-6	Vo4+	0 - 10 Vdc	1 mA
	TB2-7	Vo4-	0 Vdc	1 mA
	TB2-8	Vo4+	0 Vdc	1 mA
	TB2-9	Vo4-	0 Vdc	1 mA
	TB2-10	NO CONNECTION		
	TB2-11	PGEN 1+	0 to 5 Vdc	4 mA
	TB2-12	PGEN 1-	0 Vdc	4 mA
	TB2-13	PGEN 2+	0 to 5 Vdc	4 mA
	TB2-14	PGEN 2-	0 Vdc	4 mA
1010N+5DS2	TB3-1	K1 NO	0 - 50 Vdc	250 mA
	TB3-2	K1 NC	0 - 50 Vdc	250 mA
	TB3-3	K1 COM	0 - 50 Vdc	250 mA
	TB3-4	NO CONNECTION		
	TB3-5	K2 NO	0 - 50 Vdc	250 mA
	TB3-6	K2 NC	0 - 50 Vdc	250 mA
	TB3-7	K2 COM	0 - 50 Vdc	250 mA
	TB3-8	K3 NO	0 - 50 Vdc	250 mA
	TB3-9	K3 NC	0 - 50 Vdc	250 mA
	TB3-10	K3 COM	0 - 50 Vdc	250 mA
	TB3-11	NO CONNECTION		
	TB3-12	K4 NO	0 - 50 Vdc	250 mA
	TB3-13	K4 NC	0 - 50 Vdc	250 mA
	TB3-14	K4 COM	0 - 50 Vdc	250 mA

**NORMAL SIGNAL CHARACTERISTICS**  
(SEE NOTE 6)

MODULE	LOCATION	FUNCTION	NORMAL VOLTAGE	CURRENT
1010N+5DS2	TB3-1	1 in 1	15 Vdc Max	4 - 20 mA
	TB3-2	1 in 1 COMMON		4 - 20 mA
	TB3-3	1 in 2	15 Vdc Max	4 - 20 mA
	TB3-4	1 in 2 COMMON		4 - 20 mA
	TB4-1	1 in 3	15 Vdc Max	4 - 20 mA
	TB4-2	1 in 3 COMMON		4 - 20 mA
	TB4-3	1 in 4	15 Vdc Max	4 - 20 mA
	TB4-4	1 in 4 COMMON		4 - 20 mA
	TB5-1	1 in 1	15 Vdc Max	4 - 20 mA
	TB5-2	1 in 1 COMMON		4 - 20 mA
	TB5-3	1 in 2	15 Vdc Max	4 - 20 mA
	TB5-4	1 in 2 COMMON		4 - 20 mA

**NORMAL SIGNAL CHARACTERISTICS**  
(SEE NOTES 5 & 6)

MODULE	LOCATION	FUNCTION	NORMAL VOLTAGE	CURRENT
1010N+8MS2	TB1-1	Tx	to ±12 Vdc	4 mA
	TB1-2	RTS	to ±12 Vdc	4 mA
	TB1-3	DTR	to ±12 Vdc	4 mA
	TB1-4	Rx	to ±12 Vdc	4 mA
	TB1-5	CTS	to ±12 Vdc	4 mA
	TB1-6	GND	0 Vdc	20 mA
	TB1-7	K1 NO	0 - 50 Vdc	250 mA
	TB1-8	K1 NC	0 - 50 Vdc	250 mA
	TB1-9	K1 COM	0 - 50 Vdc	250 mA
	TB1-10	K2 NO	0 - 50 Vdc	250 mA
	TB1-11	K2 NC	0 - 50 Vdc	250 mA
	TB1-12	K2 COM	0 - 50 Vdc	250 mA
	TB1-13	K3 NO	0 - 50 Vdc	250 mA
	TB1-14	K3 NC	0 - 50 Vdc	250 mA
	TB1-15	K3 COM	0 - 50 Vdc	250 mA
	TB1-16	K4 NO	0 - 50 Vdc	250 mA
	TB1-17	K4 NC	0 - 50 Vdc	250 mA
	TB1-18	K4 COM	0 - 50 Vdc	250 mA
	TB2-1	Vo1+	0 - 10 Vdc	1 mA
	TB2-2	Vo1-	0 Vdc	1 mA
	TB2-3	Vo2+	0 - 10 Vdc	1 mA
	TB2-4	Vo2-	0 Vdc	1 mA
	TB2-5	Vo3+	0 - 10 Vdc	1 mA
	TB2-6	Vo3-	0 Vdc	1 mA
	TB2-7	Vo4+	0 - 10 Vdc	1 mA
	TB2-8	Vo4-	0 Vdc	1 mA
	TB3-1	lo1+	33 Vdc	4 - 20 mA
	TB3-2	lo1-	0 - 33 Vdc	4 - 20 mA
	TB3-3	lo2+	33 Vdc	4 - 20 mA
	TB3-4	lo2-	0 - 33 Vdc	4 - 20 mA
	TB3-5	lo3+	33 Vdc	4 - 20 mA
	TB3-6	lo3-	0 - 33 Vdc	4 - 20 mA
	TB3-7	lo4+	33 Vdc	4 - 20 mA
	TB3-8	lo4-	0 - 33 Vdc	4 - 20 mA
TB4-1	NO CONNECTION			
TB4-2	NO CONNECTION			
TB4-3	D1+	0 to 5 Vdc	5 mA	
TB4-4	D1-	0 Vdc	5 mA	
TB4-5	D2+	0 to 5 Vdc	5 mA	
TB4-6	D2-	0 Vdc	5 mA	
TB4-7	D3+	0 to 5 Vdc	5 mA	
TB4-8	D3-	0 Vdc	5 mA	
TB4-9	D4+	0 to 5 Vdc	5 mA	
TB4-10	D4-	0 Vdc	5 mA	
TB4-11	lin1+	0 - 15 Vdc	4 - 20 mA	
TB4-12	lin1-	0 Vdc	4 - 20 mA	
TB4-13	lin2+	0 - 15 Vdc	4 - 20 mA	
TB4-14	lin2-	0 Vdc	4 - 20 mA	
TB4-15	lin3+	0 - 15 Vdc	4 - 20 mA	
TB4-16	lin3-	0 Vdc	4 - 20 mA	
TB4-17	lin4+	0 - 15 Vdc	4 - 20 mA	
TB4-18	lin4-	0 Vdc	4 - 20 mA	

CHANGES TO THIS DOCUMENT REQUIRE  
SAFETY AGENCY APPROVAL

DO NOT SCALE THIS DRAWING  
UNLESS OTHERWISE SPECIFIED:  
DIMENSIONS ARE IN INCHES  
FRACTIONS- DECIMALS- ANGLES-  
+/- 1/16 XX +/- 0.01 +/- 0.30'  
MATERIAL: XXXX +/- 0.005  
FINISH:

CONTRACT NO. \_\_\_\_\_  
DR. H.J. DATE 3/29/04  
CHK \_\_\_\_\_ DATE \_\_\_\_\_  
ENG \_\_\_\_\_ DATE \_\_\_\_\_  
PRD \_\_\_\_\_ DATE \_\_\_\_\_  
APPD \_\_\_\_\_ DATE \_\_\_\_\_  
CERTIFIED \_\_\_\_\_  
DATE \_\_\_\_\_

**CONTROLTRON**  
HAUPPAUGE, NY 11788

**CONNECTION DIAGRAM**  
AGENCY APPROVED FOR ZONE 2 CONNECTIONS  
1010NS9 FLOW COMPUTER SYSTEM

SIZE: **C** CODE IDENT NO. **21614** 1010-391 REV. **C**  
SCALE: NONE WT. SHEET 3 OF 4



NORMAL SIGNAL CHARACTERISTICS (SEE NOTES 5 & 6)

MODULE	LOCATION	FUNCTION	NORMAL VOLTAGE	CURRENT
1010N-7, 1010N-7K2 OR 1010N-7K3 USED IN STANDARD, HIGH- PERFORMANCE, OR ENHANCED- PERFORMANCE FLOWMETERS	TB1-1	Tx	to ±12 Vdc	4 mA
	TB1-2	RTS	to ±12 Vdc	4 mA
	TB1-3	DIR	to ±12 Vdc	4 mA
	TB1-4	Rx	to ±12 Vdc	4 mA
	TB1-5	CTS	to ±12 Vdc	4 mA
	TB1-6	GND	0 Vdc	20 mA
	TB1-7	D1+	0 to 5 Vdc	5 mA
	TB1-8	D2+	0 to 5 Vdc	5 mA
	TB1-9	D2-	0 Vdc	5 mA
	TB1-10	D3+	0 to 5 Vdc	5 mA
	TB1-11	D3-	0 Vdc	5 mA
	TB1-12	D4+	0 to 5 Vdc	5 mA
TB1-13	D4+	0 to 5 Vdc	5 mA	
TB1-14	D4-	0 Vdc	5 mA	
TB2-1	Vo1+	0 - 10 Vdc	1 mA	
TB2-2	Vo1-	0 Vdc	1 mA	
TB2-3	Vo2+	0 - 10 Vdc	1 mA	
TB2-4	Vo2-	0 Vdc	1 mA	
TB2-5	Io1+	0 - 33 Vdc	4 - 20 mA	
TB2-6	Io1-	0 Vdc	4 - 20 mA	
TB2-7	Io2+	0 - 33 Vdc	4 - 20 mA	
TB2-8	Io2-	0 Vdc	4 - 20 mA	
TB2-9	PG1	0 to 5 Vdc	4 mA	
TB2-10	PG2	0 Vdc	4 mA	
TB2-11	PG3	0 to 5 Vdc	4 mA	
TB2-12	PG4	0 Vdc	4 mA	
TB3-1	K1 NO	0 - 50 Vdc	250 mA	
TB3-2	K1 NC	0 - 50 Vdc	250 mA	
TB3-3	K1 COM	0 - 50 Vdc	250 mA	
TB3-4	NO CONNECTION	_____	_____	
TB3-5	K2 NO	0 - 50 Vdc	250 mA	
TB3-6	K2 NC	0 - 50 Vdc	250 mA	
TB3-7	K2 COM	0 - 50 Vdc	250 mA	
TB3-8	K3 NO	0 - 50 Vdc	250 mA	
TB3-9	K3 NC	0 - 50 Vdc	250 mA	
TB3-10	K3 COM	0 - 50 Vdc	250 mA	
TB3-11	NO CONNECTION	_____	_____	
TB3-12	K4 NO	0 - 50 Vdc	250 mA	
TB3-13	K4 NC	0 - 50 Vdc	250 mA	
TB3-14	K4 COM	0 - 50 Vdc	250 mA	
TB4-1	AUX IO1+	30 Vdc Max.	4 - 20 mA	
TB4-2	AUX IO1-	30 Vdc Max.	4 - 20 mA	
TB4-3	AUX IO2+	30 Vdc Max.	4 - 20 mA	
TB4-4	AUX IO2-	30 Vdc Max.	4 - 20 mA	
TB4-5	AUX IO3+	30 Vdc Max.	4 - 20 mA	
TB4-6	AUX IO3-	30 Vdc Max.	4 - 20 mA	
TB4-7	AUX IO4+	30 Vdc Max.	4 - 20 mA	
TB4-8	AUX IO4-	30 Vdc Max.	4 - 20 mA	

NORMAL SIGNAL CHARACTERISTICS (SEE NOTES 5 & 6)

MODULE	LOCATION	FUNCTION	NORMAL VOLTAGE	CURRENT
1010N-7, 1010N-7K2 OR 1010N-7K3 USED IN STANDARD, HIGH- PERFORMANCE, OR ENHANCED- PERFORMANCE FLOWMETERS	TB1-1	Tx	to ±12 Vdc	4 mA
	TB1-2	RTS	to ±12 Vdc	4 mA
	TB1-3	DIR	to ±12 Vdc	4 mA
	TB1-4	Rx	to ±12 Vdc	4 mA
	TB1-5	CTS	to ±12 Vdc	4 mA
	TB1-6	GND	0 Vdc	20 mA
	TB1-7	D1+	0 to 5 Vdc	5 mA
	TB1-8	D1-	0 Vdc	5 mA
	TB1-9	NO CONNECTION	_____	_____
	TB1-10	NO CONNECTION	_____	_____
	TB1-11	NO CONNECTION	_____	_____
	TB1-12	NO CONNECTION	_____	_____
TB1-13	NO CONNECTION	_____	_____	
TB1-14	NO CONNECTION	_____	_____	
TB2-1	Vo1+	0 - 10 Vdc	1 mA	
TB2-2	Vo1-	0 Vdc	1 mA	
TB2-3	Vo2+	0 - 10 Vdc	1 mA	
TB2-4	Vo2-	0 Vdc	1 mA	
TB2-5	Io1+	0 - 33 Vdc	4 - 20 mA	
TB2-6	Io1-	0 Vdc	4 - 20 mA	
TB2-7	Io2+	0 - 33 Vdc	4 - 20 mA	
TB2-8	Io2-	0 Vdc	4 - 20 mA	
TB2-9	PG1	0 to 28 Vdc	5 mA	
TB2-10	PG2	0 to 5 Vdc	4 mA	
TB2-11	PG3	0 to 28 Vdc	5 mA	
TB2-12	PG4	0 to 5 Vdc	4 mA	
TB2-13	NO CONNECTION	_____	_____	
TB2-14	NO CONNECTION	_____	_____	
TB3-1	K1 NO	0 - 50 Vdc	250 mA	
TB3-2	K1 NC	0 - 50 Vdc	250 mA	
TB3-3	K1 COM	0 - 50 Vdc	250 mA	
TB3-4	NO CONNECTION	_____	_____	
TB3-5	K2 NO	0 - 50 Vdc	250 mA	
TB3-6	K2 NC	0 - 50 Vdc	250 mA	
TB3-7	K2 COM	0 - 50 Vdc	250 mA	
TB3-8	K3 NO	0 - 50 Vdc	250 mA	
TB3-9	K3 NC	0 - 50 Vdc	250 mA	
TB3-10	K3 COM	0 - 50 Vdc	250 mA	
TB3-11	NO CONNECTION	_____	_____	
TB3-12	K4 NO	0 - 50 Vdc	250 mA	
TB3-13	K4 NC	0 - 50 Vdc	250 mA	
TB3-14	K4 COM	0 - 50 Vdc	250 mA	
TB4-1	NO CONNECTION	_____	_____	
TB4-2	NO CONNECTION	_____	_____	
TB4-3	NO CONNECTION	_____	_____	
TB4-4	NO CONNECTION	_____	_____	
TB4-5	AUX IO3+	30 Vdc Max.	4 - 20 mA	
TB4-6	AUX IO3-	30 Vdc Max.	4 - 20 mA	
TB4-7	AUX IO4+	30 Vdc Max.	4 - 20 mA	
TB4-8	AUX IO4-	30 Vdc Max.	4 - 20 mA	

NORMAL SIGNAL CHARACTERISTICS (SEE NOTE 5)

MODULE	LOCATION	FUNCTION	NORMAL VOLTAGE	CURRENT
1015N-5M	J2-1	DCD	to ±12 Vdc	22 mA
	J2-2	RX	to ±12 Vdc	22 mA
	J2-3	TX	to ±12 Vdc	22 mA
	J2-4	DTR	to ±12 Vdc	22 mA
	J2-5	GND	0 Vdc	75 mA
	J2-6	N/C	_____	_____
	J2-7	RTS	to ±12 Vdc	22 mA
	J2-8	CTS	to ±12 Vdc	22 mA
	J2-9	TX+	0 to 5 Vdc	25 mA
	J2-10	TX-	0 to 5 Vdc	25 mA
	J2-11	RX+	0 to 5 Vdc	25 mA
	J2-12	RX-	0 to 5 Vdc	25 mA

CHANGES TO THIS DOCUMENT REQUIRE SAFETY AGENCY APPROVAL

**CONTROLTRON**  
HAUPPAUGE, NY 11788

**CONNECTION DIAGRAM**  
AGENCY APPROVED FOR ZONE 2 CONNECTIONS  
1010NS8 FLOW COMPUTER SYSTEM

DATE: 3/29/04  
DR: HJJ  
CHK: \_\_\_\_\_  
ENG: \_\_\_\_\_  
PROJ: \_\_\_\_\_  
APPD: \_\_\_\_\_  
CERTIFIED: \_\_\_\_\_  
DATE: \_\_\_\_\_

SIZE: **C** CODE IDENT NO: **21614** REV: **C**  
SCALE: NONE WT. SHEET 4 OF 4

DO NOT SCALE THIS DRAWING  
UNLESS OTHERWISE SPECIFIED:  
DIMENSIONS ARE IN INCHES  
FRACTIONS- DECIMALS- ANGLES-  
+/- 1/16 XX +/- 0.01 +/- 0.30  
XX +/- 0.005

MATERIAL: \_\_\_\_\_  
FINISH: \_\_\_\_\_

CONTRACT NO. \_\_\_\_\_  
DATE: \_\_\_\_\_





### REFLECT MODE OPERATION

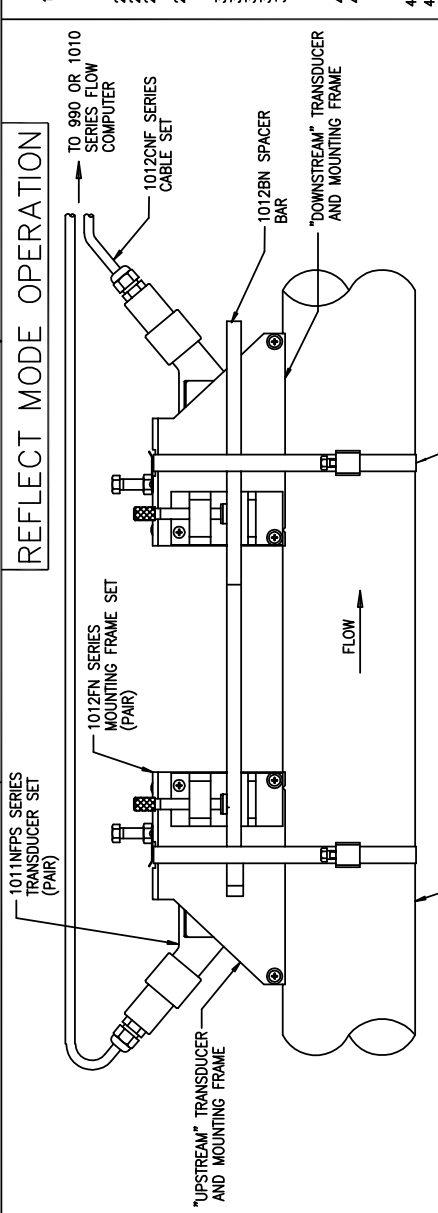

1011NFPS SERIES TRANSDUCER SET (PAIR)  
 1012FN SERIES MOUNTING FRAME SET (PAIR)  
 1012CNF SERIES CABLE SET  
 1012BN SPACER BAR  
 1012MS SERIES MOUNTING STRAP KIT  
 CUSTOMER'S PIPE  
 FLOW

**INSTALLATION NOTES** - SEE DRAWING REFERENCE **A**

- USING THE INSTALLATION MENU AND THE PROCEDURE OUTLINED IN THE FLOW COMPUTER FIELD MANUAL, CONFIRM THAT YOU HAVE THE APPROPRIATE TRANSDUCERS AND SPACER BAR (IF USED) FOR REFLECT MODE OPERATION ON THE CHOSEN PIPE.
- SELECT MOUNTING LOCATION:
  - CHOOSE LOCATION WHICH REMAINS FULL AT ZERO FLOW
  - WHERE POSSIBLE LOCATE TRANSDUCERS TO PIPE DIAMETERS OR MORE FROM BEND TO ENSURE FULLY DEVELOPED AND STABLE FLOW PROFILE.
  - ON HORIZONTAL PIPE, SELECT HORIZONTAL PLANE, IF POSSIBLE TO AVOID SEDIMENT BLOCKAGE OF ULTRASONIC BEAM.
- PREPARE PIPE FOR TRANSDUCER MOUNTING:
  - REMOVE GRIT, CORROSION, COATING OR HEAVY PAINT
  - CLEAN AND DEGREASE SURFACE
  - DO NOT MOUNT OVER FROST.
  - CONDITION PIPE SURFACE:
    - LOCATE THE PIPE SURFACE TO ACCEPT THE TRANSDUCERS. USE THE ABRASIVE PAD PROVIDED.
- INSTALLATION WITH MOUNTING FRAMES
  - CONSULT THE 1010 FIELD MANUAL AND USE THE INSTALLATION MENU TO SELECT THE APPROPRIATE INDEX HOLE OR SPACING (LTN) FOR YOUR APPLICATION.
    - IF SPACER BAR IS USED:
      - CLAMP ONE MOUNTING FRAME AT THE UN-NUMBERED REFERENCE POSITION OF THE SPACER BAR. BE SURE THE INDEX PIN AND SPACER BAR INDEX SCREW ENGAGE THE HOLE IN THE SPACER BAR.
      - CLAMP THE SECOND MOUNTING FRAME TO THE SPACER BAR IN THE SAME MANNER AT THE INDEX HOLE INDICATED DURING STEP 4.1.
      - HOLD THE MOUNTING FRAME/SPACER BAR ASSEMBLY ON THE PIPE AT THE SELECTED LOCATION AND TEMPORARILY SECURE IT TO THE PIPE USING STRAPS FROM THE 1012MS STRAP MOUNTING KIT. GO TO 4.4.
    - IF MOUNTING FRAMES ARE SPACED BY MEASURING "L"IN":
      - TEMPORARILY SECURE ONE OF THE MOUNTING FRAMES TO THE PIPE USING STRAPS FROM THE 1012MS STRAP MOUNTING KIT.
      - MEASURE ALONG THE PIPE AND TEMPORARILY SECURE THE SECOND MOUNTING FRAME TO THE PIPE SO THAT SPACING "L"IN" DETERMINED IN STEP 4.1 IS MEASURED BETWEEN THE SPACING MARKS ON THE MOUNTING FRAMES.
      - IF THE PIPE SURFACE IS CLEAN AND SMOOTH, PROCEED TO TRANSDUCER INSTALLATION ON SHIT.3. IF PIPE SURFACE NEEDS CONDITIONING; MARK THE MOUNTING FRAME POSITION CAREFULLY; LOOSEN STRAPS AND MOVE THE MOUNTING FRAMES ASIDE. LOCALLY SMOOTH THE PIPE SURFACE IN THE MARKED AREAS USING THE ABRASIVE PAD SUPPLIED. SHIFT THE MOUNTING FRAMES BACK INTO THEIR APPROPRIATE LOCATIONS AND TIGHTEN THE MOUNTING STRAPS SECURELY.

**SECURING MOUNTING FRAMES TO THE PIPE SURFACE**

HOLD THE MOUNTING FRAME/SPACER BAR ASSEMBLY AGAINST THE PIPE AT THE SELECTED MOUNTING LOCATION. MARK THE APPROXIMATE OUTLINE OF THE MOUNTING FRAMES ON THE PIPE SURFACE. USING THE ABRASIVE PAD SUPPLIED, SMOOTH THE PIPE SURFACE IN THE MARKED AREAS. SECURE THE MOUNTING FRAMES TO THE PIPE USING THE MOUNTING STRAP KIT (1012MS). SEE DRAWING 1012MS-8.

ABRADE TO SMOOTH FINISH, TWO PLACES

**PREFERRED MOUNTING PLANE**

HORIZONTAL

2.3

MOUNT TRANSDUCERS/MOUNTING FRAMES IN HORIZONTAL PLANE TO PREVENT BLOCKING OF ULTRASONIC BEAM BY AIR OR SEDIMENT.

**USING THE SPACER BAR TO SET TRANSDUCER MOUNTING FRAME SPACING**

USING THE INSTALLATION MENU, AS OUTLINED IN THE FLOW COMPUTER FIELD MANUAL, DETERMINE THE SPACING INDEX NUMBER FOR THE SELECTED APPLICATION.

USE THE SPACER BAR INDEX SCREW TO SECURE THE SPACER BAR TO ONE OF THE MOUNTING FRAMES AT THE UN-NUMBERED REFERENCE POSITION.

SPACER BAR INDEX SCREW  
 UN-NUMBERED REFERENCE POSITION  
 NUMBERED INDEX POSITIONS  
 SPACER BAR

SEE SHEET 4 FOR MOUNTING FRAMES INSTALLATION WITHOUT MOUNTING FRAMES

\*\* SEE SHEET 3 FOR INSTRUCTIONS TO COMPLETE TRANSDUCER INSTALLATION.

DO NOT SCALE THIS DRAWING UNLESS OTHERWISE SPECIFIED: DIMENSIONS ARE IN INCHES (MM)		CONTRACT NO.	
DR	H.J	DATE	7/7/99
CHK		DATE	
ENG		DATE	
PROD		DATE	
APPD		DATE	
CERTIFIED			
		DATE	

USE THE SPACER BAR INDEX SCREW TO SECURE THE SPACER BAR TO ONE OF THE MOUNTING FRAMES AT THE UN-NUMBERED REFERENCE POSITION.

SECURE THE SECOND MOUNTING FRAME TO THE SPACER BAR AT THE NUMBERED INDEX POSITION DETERMINED FROM THE INSTALLATION MENU.

**CONTROLTRON**  
 HAUPPAUGE, NY 11788

**INSTALLATION, 1011NFPS SERIES DEDICATED PLASTIC BODY TRANSDUCER**

SIZE CODE IDENT NO. **C 21614** REV. **B**

SCALE: NONE WT. SHEET 1 OF 4



4 3 2 1

**MATING 1012CNF SERIES TRANSDUCER CABLES WITH 1011NFPS SERIES TRANSDUCERS**

- REMOVE PROTECTIVE CAPS.
- SEE APPROPRIATE CABLE ASSEMBLY DRAWING FOR 'F' CONNECTOR, NPT ADAPTER AND GLAND ASSEMBLY DETAIL.
- MATE 'F' CONNECTORS, CABLES TO TRANSDUCER.
- FOR BEST WEATHER SEAL, WRAP TEFLON PIPE TAPE (NOT SUPPLIED) AROUND MALE NPT THREADS ON TRANSDUCER HOUSING.
- SCREW NPT ADAPTER TO TRANSDUCER HOUSING (HAND TIGHT IS SUFFICIENT).
- TIGHTEN GLAND BODY WITH NPT ADAPTER AND SECURE CABLE BY TIGHTENING GLAND TOP NUT. (HAND TIGHT IS SUFFICIENT).

**INSTALLATION NOTES** - CONT'D FROM SHT. 1 OR SHT. 2

- MAKE CABLE CONNECTIONS AT FLOW COMPUTER IN ACCORDANCE WITH APPROPRIATE FLOW COMPUTER INSTALLATION DRAWING AND 1010 FIELD MANUAL.
- SEE DRAWINGS 1012FN-8 AND 1011NFPS-8 FOR MOUNTING FRAME AND TRANSDUCER OUTLINE DIMENSIONS.

**INSTALLING TRANSDUCERS IN MOUNTING FRAMES**

APPLY A THIN BAND OF COUPLANT TO THE EMITTING SURFACE OF THE TRANSDUCERS. SLIP THE TRANSDUCERS INTO THE MOUNTING FRAMES, SEATING THEM SQUARELY ON THE PIPE SURFACE. PUSH FORWARD INTO THE FRAMES AGAINST THE FRONT SPACER, TIGHTEN THE TRANSDUCER CLAMPING SCREW, FIRMLY SEATING THE TRANSDUCERS ON THE PIPE SURFACE. SECURE THE CLAMPING SCREW WITH THE LOCKNUT.

\*\*SEE DRAWING 1012TP-7 FOR INSTALLATION USING 1012TP SERIES MOUNTING TRACKS.

**USE OF FLEXIBLE CONDUIT WITH TRANSDUCERS**

THE TRANSDUCER WIRING HOUSING HAS INTEGRAL 1/2" N.P.T. THREADS TO ACCEPT A CONDUIT COUPLING IF FLEXIBLE CONDUIT IS USED. MAKE CONNECTION AS SHOWN, THEN PASS COUPLING AND CONDUIT OVER THE CABLE, SECURE TO THE TRANSDUCER WIRING HOUSING.

DO NOT SCALE THIS DRAWING UNLESS OTHERWISE SPECIFIED. DIMENSIONS ARE IN INCHES (MM) TOLERANCES ON-

INCHES ± .1 (MM) ± 2

CONTRACT NO.

DR HJJ DATE 7/7/99  
 CHK DATE  
 ENG DATE  
 PRD DATE  
 APPD DATE  
 CERTIFIED  
 DATE

**CONTROLTRON**  
 HAUPPAGE, NY 11788

**INSTALLATION, 1011NFPS SERIES DEDICATED PLASTIC BODY TRANSDUCER**

SIZE	CODE IDENT NO.	REV.
C 21614	1011NFPS-7	B
SCALE: NONE	WT.	SHEET 3 OF 4

2

3

4

R14: 1011NFPS-7 rev.B  
 CN4333

**INSTALLATION OF TRANSDUCERS WITHOUT MOUNTING FRAMES**

THE SAME GENERAL NOTES AND PROCEDURES APPLY WHEN INSTALLING TRANSDUCERS WITHOUT THE BENEFIT OF MOUNTING FRAMES. APPLY THE FOLLOWING ALTERNATES TO THE INSTALLATION NOTES ON SHEETS 1 & 2.

- 4.2 IF SPACER BAR IS USED:  
 alt.4.2.1 SECURE ONE TRANSDUCER AT THE UN-NUMBERED REFERENCE POSITION OF THE SPACER BAR BY ENGAGING ONE OF THE SCREWS STORED IN THE SPACER BAR CAP WITH THE THREADED INSERT IN THE SIDE OF THE TRANSDUCER BLOCK.  
 alt.4.2.2 SECURE THE SECOND TRANSDUCER TO THE SPACER BAR IN THE SAME MANNER AT THE INDEX HOLE INDICATED DURING STEP 4.1.  
 alt.4.2.3 HOLD TRANSDUCER/SPACER BAR ASSEMBLY ON THE PIPE AT THE SELECTED LOCATION AND TEMPORARILY SECURE IT TO THE PIPE USING STRAPS FROM THE 1012MS STRAP MOUNTING KIT.
- 4.3 IF TRANSDUCERS ARE SPACED BY MEASURING "LN":  
 alt.4.3.1 TEMPORARILY SECURE ONE OF THE TRANSDUCERS TO THE PIPE USING STRAPS FROM THE 1012MS STRAP MOUNTING KIT.  
 alt.4.3.2 MEASURE ALONG THE PIPE AND TEMPORARILY SECURE THE SECOND TRANSDUCER TO THE PIPE SO THAT SPACING "LN" DETERMINED IN STEP 4.1 IS MEASURED BETWEEN THE SPACING MARKS ON THE FRONT FACES OF THE TRANSDUCERS. USE A STRAIGHT EDGE OR OTHER MEANS TO ALIGN BOTH TRANSDUCERS WITH THE PIPE AXIS.

FOR REFLECT MODE INSTALLATION GO TO STEP alt.4.5 FOR DIRECT MODE INSTALLATION CONTINUE WITH alt.4.4.

alt.4.4 USE THE MOUNTING GUIDE INCLUDED WITH THE 1012MS STRAP MOUNTING KIT TO TRANSFER ONE OF THE TRANSDUCERS TO THE OPPOSITE SIDE OF THE PIPE. (SEE SHEET 2, ZONE A4)

alt.4.4.1 WRAP THE MOUNTING GUIDE AROUND THE PIPE POSITION IT SO THAT THE OVERLAPPING LENGTHS ARE EDGE-ALIGNED. MARK THE OVERLAPPED PORTION OF THE GUIDE AT THE EDGE OF THE OVERLAPPING PORTION. REMOVE THE GUIDE. MEASURE THE DISTANCE FROM THE END TO THE MARK AND MARK AGAIN HALFWAY BETWEEN.

alt.4.4.2 RE-POSITION THE GUIDE ON THE PIPE AND TAPE IN PLACE SO THAT ONE OF THE MARKS INDICATES THE CENTERLINE OF THE INSTALLED TRANSDUCER AND THE MOUNTING GUIDE EDGE IS AGAINST THE END OF ONE OF THE TRANSDUCERS. MAKE SURE THE OVERLAPPING LENGTHS OF THE MOUNTING GUIDE ARE EDGE-ALIGNED. THIS ASSURES A DYMETRICAL TRANSFER OF THE TRANSDUCER POSITION.

alt.4.4.3 LOOSEN THE MOUNTING STRAP ON THE TRANSDUCER WITH WHICH THE MOUNTING GUIDE HAS BEEN ALIGNED. ROTATE IT AROUND THE PIPE SURFACE UNTIL IT IS CENTERED ON THE OPPOSITE SIDE MOUNTING GUIDE MARK. MAKE IN STEP alt.4.4.1. TIGHTEN THE STRAP. REMOVE THE MOUNTING GUIDE.

alt.4.5 WITH THE TRANSDUCERS TEMPORARILY STRAPPED IN PLACE, MARK THE PIPE SURFACE AT THE TRANSDUCER PERIMETER. REMOVE THE TRANSDUCERS FROM THE PIPE. IF THE PIPE SURFACE IS CLEAN AND SMOOTH, PROCEED TO STEP alt.4.6. IF THE PIPE SURFACE NEEDS CONDITIONING, LOCALLY SMOOTH THE SURFACE IN THE MARKED AREAS USING THE ABRASIVE PAD SUPPLIED. DO NOT OBSCURE THE MARKED TRANSDUCER LOCATIONS.

alt.4.6 APPLY A THIN BAND OF COUPLANT TO THE EMITTING SURFACE OF BOTH TRANSDUCERS. CAREFULLY REPLACE THE TRANSDUCERS ON THE PIPE, REPEATING THE PROCEDURE ABOVE, IF REQUIRED, TO ASSURE ACCURATE POSITIONING.

CONTINUE WITH INSTALLATION NOTE 5 AND CABLE CONNECTING INSTRUCTIONS ON SHEET 3.

<b>CONTROLTRON</b> HAUPPAUSE, NY 11788	
<b>INSTALLATION, 1011NFPFS SERIES DEDICATED PLASTIC BODY TRANSDUCER</b>	
SIZE	REV. B
CODE IDENT NO. <b>C 21614</b>	1011NFPFS-7
SCALE: NONE	WT.
SHEET 4 OF 4	

DO NOT SCALE THIS DRAWING UNLESS OTHERWISE SPECIFIED. DIMENSIONS ARE IN INCHES (MM) TOLERANCES ON:	
INCHES ± .1	(MM) ± 2
CONTRACT NO.	DATE
DR: HJJ	DATE: 7/17/98
CHK:	DATE:
ENG:	DATE:
PROD:	DATE:
APPD:	DATE:
CERTIFIED:	DATE:

**REFLECT MODE OPERATION**

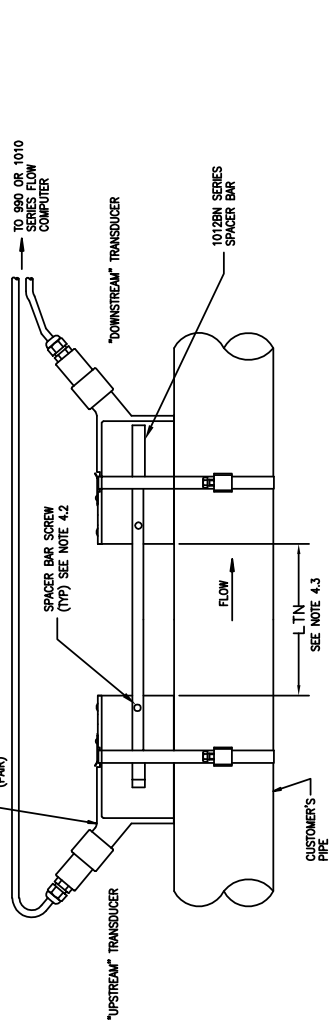

**DIRECT MODE OPERATION**

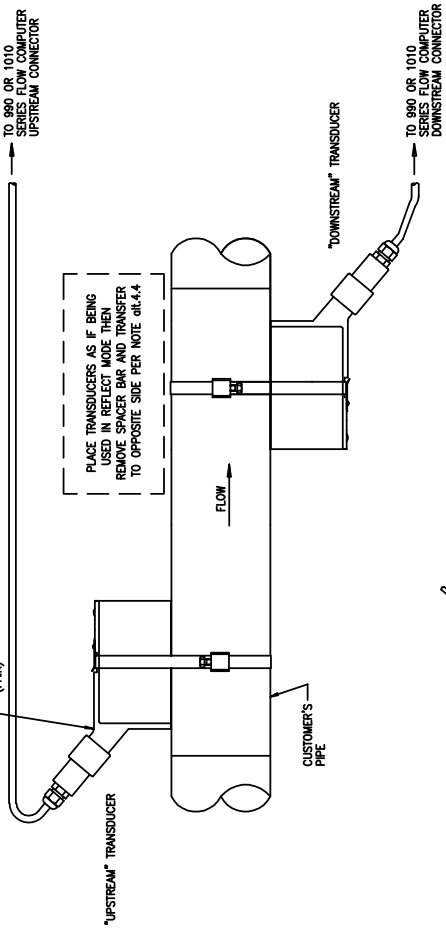

**AUXILIARY VIEW**

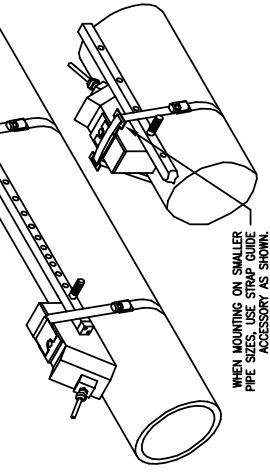





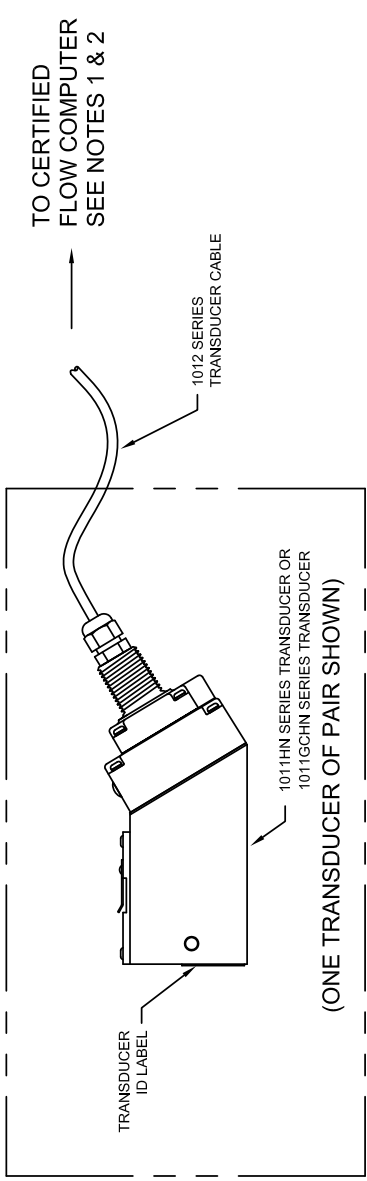

1. INSTALL ONE OF THE FOLLOWING TRANSDUCERS  
 P/N 1011HN(MODEL CODES)-(SIZE)-S9  
 P/N 1011GCHN(MODEL CODES)-(SIZE)-S9  
 IN ACCORDANCE WITH THE FOLLOWING DRAWINGS:

- a. FOR USE WITH 1010 SERIES AGENCY APPROVED FLOW COMPUTERS-  
 INTRINSICALLY SAFE EEx ia IIC T5 PER DRAWING 1010-389, 1010-422. OR 1010-464.
- b. NON-INCENDIVE FOR ZONE 2 PER DRAWING 1010-389, 1010-391, 1010-423 OR 1010-464.

2. SEE DRAWING 1011HNS-7 OR 1011HNFS-7 AND APPROPRIATE FLOW COMPUTER FIELD MANUAL FOR ADDITIONAL INSTALLATION INSTRUCTIONS.

3. SEE DRAWING 1011HNS-8 OR 1011HNFS-8 FOR OUTLINE INSTALLATION DIMENSIONS.

4. WARNING: SUBSTITUTION WITH UNSPECIFIED COMPONENTS MAY IMPAIR INTRINSIC SAFETY.

CHANGES TO THIS DOCUMENT  
 REQUIRE SAFETY AGENCY APPROVAL

DO NOT SCALE THIS DRAWING UNLESS OTHERWISE SPECIFIED: DIMENSIONS ARE IN INCHES (MM) TOLERANCES ON- INCHES                    (MM) +/- .01                    +/- .2		CONTRACT NO. DR    CHEV.    DATE    5/16/01 CHK            DATE ENG            DATE PRD            DATE APPD          DATE CERTIFIED DATE		CONTROLTRON HAUPPAUGE, NY 11788 INSTALLATION GUIDE, CONNECTION DIAGRAM SELECTION AGENCY APPROVED 1011HN SERIES TRANSDUCERS	
SIZE    CODE IDENT. NO.    REV. A    21614    1011HNS9-7    C1		SCALE:                    WT.                    SHEET 1 of 1		1011HNS9-7    1    CN#4931	

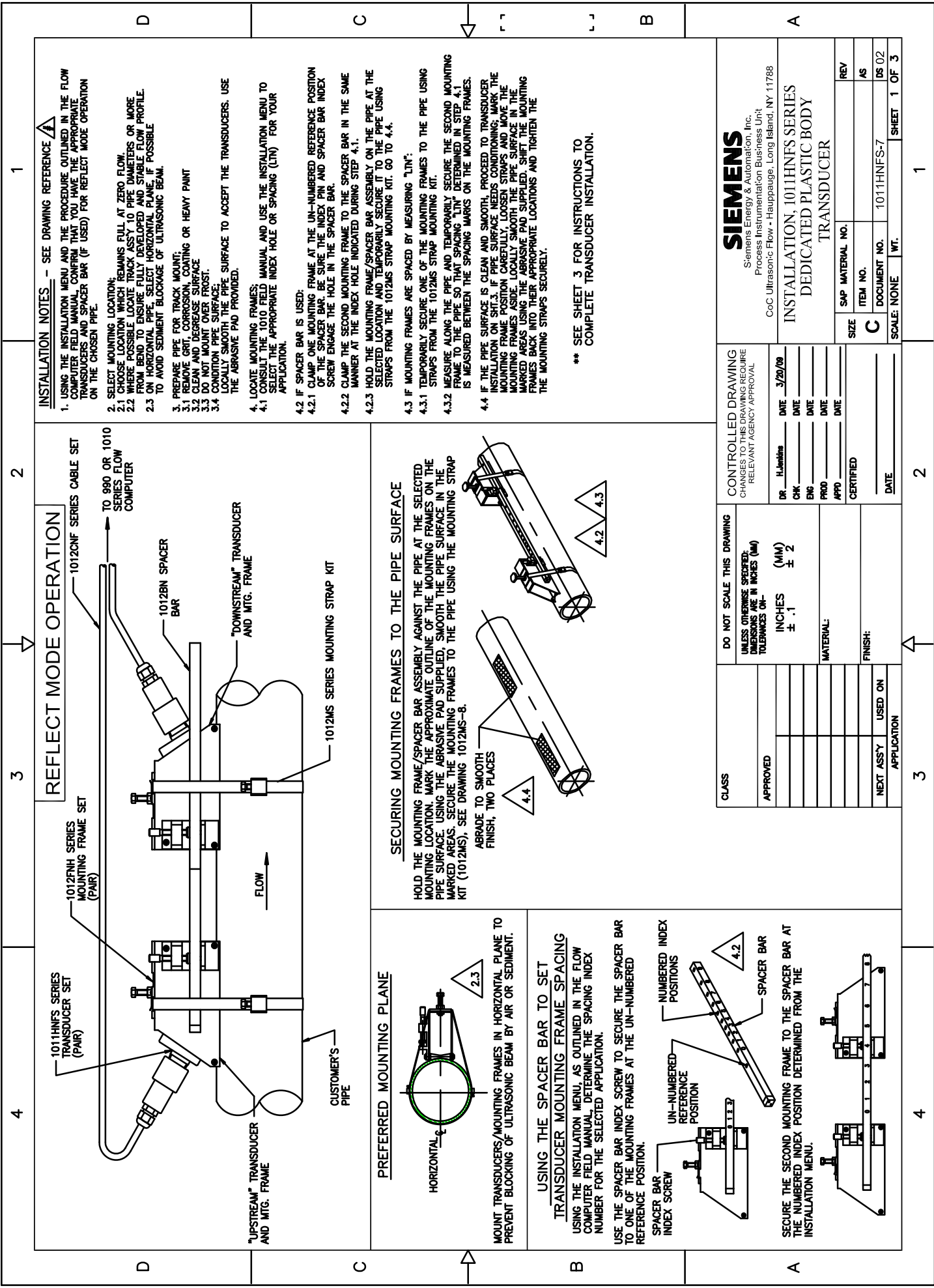

**REFLECT MODE OPERATION**

**INSTALLATION NOTES** - SEE DRAWING REFERENCE **A**

- USING THE INSTALLATION MENU AND THE PROCEDURE OUTLINED IN THE FLOW COMPUTER FIELD MANUAL, CONFIRM THAT YOU HAVE THE APPROPRIATE TRANSDUCERS AND SPACER BAR (IF USED) FOR REFLECT MODE OPERATION ON THE CHOSEN PIPE.
- SELECT MOUNTING LOCATION;
  - CHOOSE LOCATION WHICH REMAINS FULL AT ZERO FLOW.
  - WHERE POSSIBLE LOCATE TRACK ASSY TO PIPE DIAMETERS OR MORE FROM BEND TO ENSURE FULLY DEVELOPED AND STABLE FLOW PROFILE.
  - ON HORIZONTAL PIPE, SELECT HORIZONTAL PLANE. IF POSSIBLE TO AVOID SEDIMENT BLOCKAGE OF ULTRASONIC BEAM.
- PREPARE PIPE FOR TRACK MOUNT;
  - REMOVE GRIT, CORROSION, COATING OR HEAVY PAINT
  - CLEAN AND DEGREASE SURFACE
  - DO NOT MOUNT OVER FROST.
  - CONDITION PIPE SURFACE.
  - LOCALLY SMOOTH THE PIPE SURFACE TO ACCEPT THE TRANSDUCERS. USE THE ABRASIVE PAD PROVIDED.
- LOCATE MOUNTING FRAMES;
  - CONSULT THE 1010 FIELD MANUAL AND USE THE INSTALLATION MENU TO SELECT THE APPROPRIATE INDEX HOLE OR SPACING (LIN) FOR YOUR APPLICATION.
- IF SPACER BAR IS USED:
  - CLAMP ONE MOUNTING FRAME AT THE UN-NUMBERED REFERENCE POSITION OF THE SPACER BAR. BE SURE THE INDEX PIN AND SPACER BAR INDEX SCREW ENGAGE THE HOLE IN THE SPACER BAR.
  - CLAMP THE SECOND MOUNTING FRAME TO THE SPACER BAR IN THE SAME MANNER AT THE INDEX HOLE INDICATED DURING STEP 4.1.
  - HOLD THE MOUNTING FRAME/SPACER BAR ASSEMBLY ON THE PIPE AT THE SELECTED LOCATION AND TEMPORARILY SECURE IT TO THE PIPE USING STRAPS FROM THE 1012MS STRAP MOUNTING KIT. GO TO 4.4.
- IF MOUNTING FRAMES ARE SPACED BY MEASURING "LIN":
  - TEMPORARILY SECURE ONE OF THE MOUNTING FRAMES TO THE PIPE USING STRAPS FROM THE 1012MS STRAP MOUNTING KIT.
  - MEASURE ALONG THE PIPE AND TEMPORARILY SECURE THE SECOND MOUNTING FRAME TO THE PIPE SO THAT SPACING "LIN" DETERMINED IN STEP 4.1 IS MEASURED BETWEEN THE SPACING MARKS ON THE MOUNTING FRAMES.
  - IF THE PIPE SURFACE IS CLEAN AND SMOOTH, PROCEED TO TRANSDUCER INSTALLATION ON SHT.3. IF PIPE SURFACE NEEDS CONDITIONING; MARK THE MOUNTING FRAME POSITION CAREFULLY, LOOSEN STRAPS AND MOVE THE MOUNTING FRAMES ASIDE. LOCALLY SMOOTH THE PIPE SURFACE IN THE MARKED AREAS USING THE ABRASIVE PAD SUPPLIED. SHIFT THE MOUNTING FRAMES BACK INTO THEIR APPROPRIATE LOCATIONS AND TIGHTEN THE MOUNTING STRAPS SECURELY.

**SECURING MOUNTING FRAMES TO THE PIPE SURFACE**

HOLD THE MOUNTING FRAME/SPACER BAR ASSEMBLY AGAINST THE PIPE AT THE SELECTED MOUNTING LOCATION. MARK THE APPROXIMATE OUTLINE OF THE MOUNTING FRAMES ON THE PIPE SURFACE. USING THE ABRASIVE PAD SUPPLIED, SMOOTH THE PIPE SURFACE IN THE MARKED AREAS. SECURE THE MOUNTING FRAMES TO THE PIPE USING THE MOUNTING STRAP KIT (1012MS). SEE DRAWING 1012MS-8.

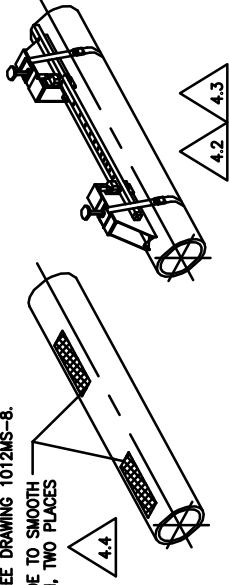

**PREFERRED MOUNTING PLANE**

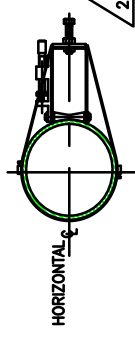

MOUNT TRANSDUCERS/MOUNTING FRAMES IN HORIZONTAL PLANE TO PREVENT BLOCKING OF ULTRASONIC BEAM BY AIR OR SEDIMENT.

**USING THE SPACER BAR TO SET TRANSDUCER MOUNTING FRAME SPACING**

USING THE INSTALLATION MENU, AS OUTLINED IN THE FLOW COMPUTER FIELD MANUAL, DETERMINE THE SPACING INDEX NUMBER FOR THE SELECTED APPLICATION.

USE THE SPACER BAR INDEX SCREW TO SECURE THE SPACER BAR TO ONE OF THE MOUNTING FRAMES AT THE UN-NUMBERED REFERENCE POSITION.

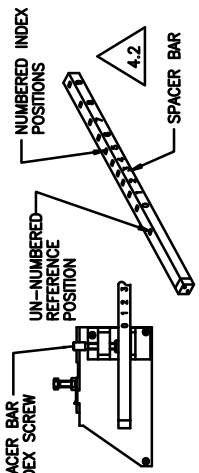

SECURE THE SECOND MOUNTING FRAME TO THE SPACER BAR AT THE NUMBERED INDEX POSITION DETERMINED FROM THE INSTALLATION MENU.

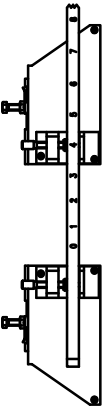

\*\* SEE SHEET 3 FOR INSTRUCTIONS TO COMPLETE TRANSDUCER INSTALLATION.

CLASS	DO NOT SCALE THIS DRAWING		CONTROLLED DRAWING	
	UNLESS OTHERWISE SPECIFIED: DIMENSIONS ARE IN INCHES (MM) TOLERANCES ON-		CHANGES TO THIS DRAWING REQUIRE RELEVANT AGENCY APPROVAL	
APPROVED	INCHES ± .1	DATE 3/20/09	DR H.Johnson	DATE
	(MM) ± .2	DATE	CHK	DATE
	MATERIAL:	DATE	ENG	DATE
	FINISH:	DATE	APPD	DATE
NEXT ASSY USED ON		CERTIFIED		
APPLICATION		DATE		

**SIEMENS**

Siemens Energy & Automation, Inc.  
Process Instrumentation Business Unit  
CoC Ultrasonic Flow - Heppauge, Long Island, NY 11788

INSTALLATION, 1011HNFs SERIES  
DEDICATED PLASTIC BODY  
TRANSDUCER

SIZE	SAP MATERIAL NO.	REV
C	ITEM NO.	AS
SCALE: NONE	DOCUMENT NO. 1011HNFs-7	DS 02
WT.		SHEET 1 OF 3

**DIRECT MODE OPERATION**

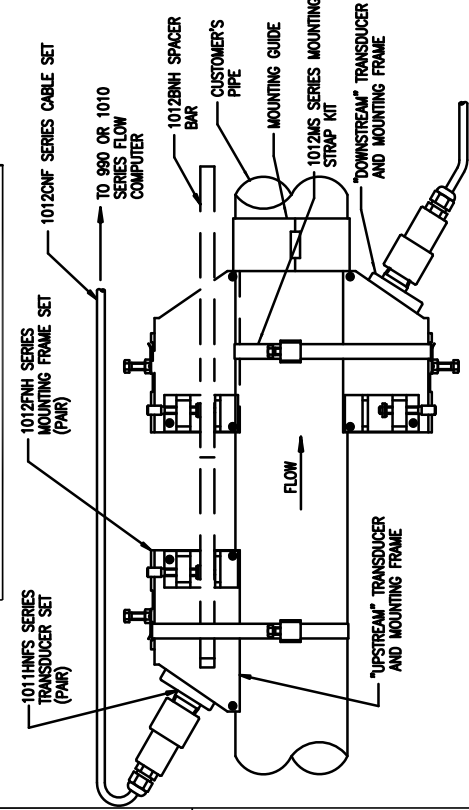

**SECURING MOUNTING FRAMES TO THE PIPE SURFACE**  
 HOLD THE MOUNTING FRAME/SPACER BAR ASSEMBLY AGAINST THE PIPE AT THE SELECTED MOUNTING LOCATION OR POSITION USING LTN, TEMPORARILY STRAP IN PLACE.

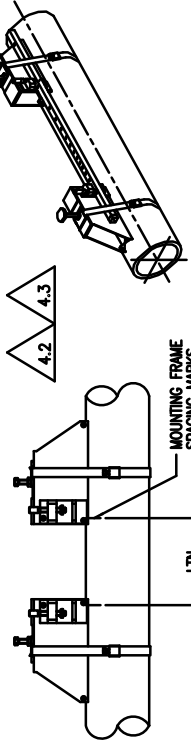

USE THE MOUNTING GUIDE TO TRANSFER ONE OF THE MOUNTING FRAMES TO THE OPPOSITE SIDE OF THE PIPE.

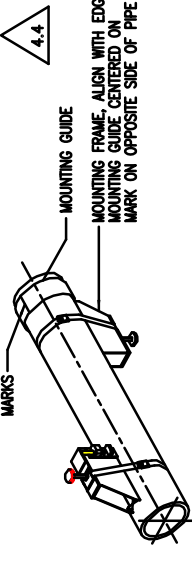

IF NECESSARY, USE THE ABRASIVE PAD SUPPLIED TO PRODUCE A SMOOTH FINISH ON THE PIPE AT THE TRANSDUCER MOUNTING POSITIONS.

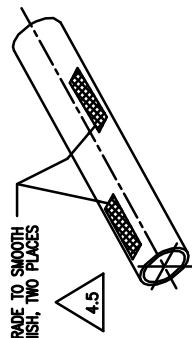

**PREFERRED MOUNTING PLANE**

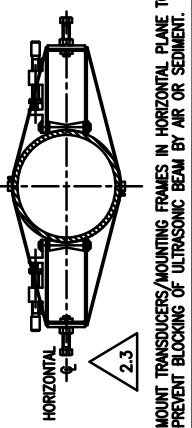

**USING THE SPACER BAR TO SET TRANSDUCER MOUNTING FRAME SPACING**  
 USING THE INSTALLATION MENU, AS OUTLINED IN THE FLOW COMPUTER FIELD MANUAL, DETERMINE THE SPACING INDEX NUMBER FOR THE SELECTED APPLICATION. USE THE SPACER BAR INDEX SCREW TO SECURE THE SPACER BAR TO ONE OF THE MOUNTING FRAMES AT THE UN-NUMBERED REFERENCE POSITION.

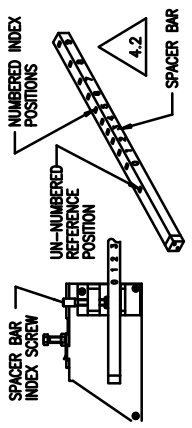

SECURE THE SECOND MOUNTING FRAME TO THE SPACER BAR AT THE NUMBERED INDEX POSITION DETERMINED FROM THE INSTALLATION MENU.

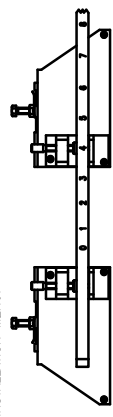

WRAP MOUNTING GUIDE AROUND PIPE AND MARK AT OVERLAPPING EDGE. UNWRAP GUIDE, MEASURE DISTANCE 1/2" FROM EDGE TO MARK, MARK AGAIN AT 1/2". RE-INSTALL THE MOUNTING GUIDE, TAPE IN PLACE WITH BOTH MARKS VISIBLE. ALIGN ONE MARK WITH THE CENTER LINE OF THE MOUNTING FRAMES.

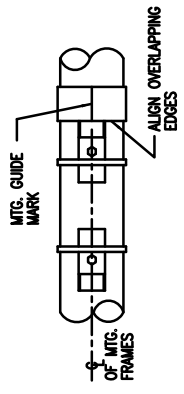
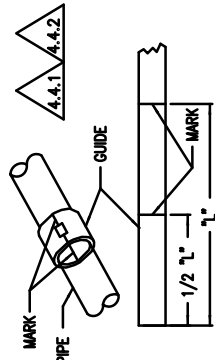

**INSTALLATION NOTES** - SEE DRAWING REFERENCE **A**

1. USING THE INSTALLATION MENU AND THE PROCEDURE OUTLINED IN THE FLOW COMPUTER FIELD MANUAL, CONFIRM THAT YOU HAVE THE APPROPRIATE TRANSDUCERS AND SPACER BAR (IF USED) FOR DIRECT MODE OPERATION ON THE CHOSEN PIPE.
  - 2.1 CHOOSE LOCATION WHICH REMAINS FULL AT ZERO FLOW.
  - 2.2 WHERE POSSIBLE LOCATE TRACK ASSY TO PIPE DIAMETERS OR MORE FROM BEND TO ENSURE FULLY DEVELOPED AND STABLE FLOW PROFILE.
  - 2.3 ON HORIZONTAL PIPE, SELECT HORIZONTAL PLANE, IF POSSIBLE.
2. SELECT MOUNTING LOCATION:
  - 3.1 PREPARE PIPE FOR TRACK MOUNT.
  - 3.2 CLEAN AND DEGREASE SURFACE.
  - 3.3 DO NOT MOUNT OVER FROST.
  - 3.4 CONDITION PIPE SURFACE.
3. LOCATE MOUNTING FRAMES:
  - 4.1 CONSULT THE 1010 FIELD MANUAL AND USE THE INSTALLATION MENU TO SELECT THE APPROPRIATE INDEX HOLE OR SPACING (LTN) FOR YOUR APPLICATION.
  - 4.2 IF SPACER BAR IS USED:
    - 4.2.1 CLAMP ONE MOUNTING FRAME AT THE UN-NUMBERED REFERENCE POSITION OF THE SPACER BAR. BE SURE THE INDEX PIN AND SPACER BAR INDEX SCREW ENGAGE THE HOLE IN THE SPACER BAR.
    - 4.2.2 CLAMP THE SECOND MOUNTING FRAME TO THE SPACER BAR IN THE SAME MANNER AT THE INDEX HOLE INDICATED DURING STEP 4.1.
    - 4.2.3 HOLD THE MOUNTING FRAME/SPACER BAR ASSEMBLY ON THE PIPE AT THE SELECTED LOCATION AND TEMPORARILY SECURE IT TO THE PIPE USING STRAPS FROM THE 1012MS STRAP MOUNTING KIT. GO TO 4.4.
  - 4.3 IF MOUNTING FRAMES ARE SPACED BY MEASURING "L":
    - 4.3.1 TEMPORARILY SECURE ONE OF THE MOUNTING FRAMES TO THE PIPE USING STRAPS FROM THE 1012MS STRAP MOUNTING KIT.
    - 4.3.2 MEASURE ALONG THE PIPE AND TEMPORARILY SECURE THE SECOND MOUNTING FRAME TO THE PIPE USING STRAPS FROM THE 1012MS STRAP MOUNTING KIT. MEASURE THE DISTANCE BETWEEN THE SPACING MARKS ON THE MOUNTING FRAMES. USE A STRAIGHT EDGE OR OTHER MEANS TO ALIGN BOTH MOUNTING FRAMES WITH PIPE AXIS.
    - 4.3.3 USE THE MOUNTING GUIDE INCLUDED WITH THE 1012MS STRAP MOUNTING KIT TO TRANSFER ONE OF THE MOUNTING FRAMES TO THE OPPOSITE SIDE OF THE PIPE.
    - 4.3.4 WRAP THE MOUNTING GUIDE AROUND THE PIPE. POSITION IT SO THAT THE OVERLAPPING EDGES ARE EDGE-ALIGNED. MARK THE OVERLAPPING PORTION OF THE GUIDE AT THE EDGE OF THE OVERLAPPING PORTION. REMOVE THE GUIDE. MEASURE THE DISTANCE FROM THE END TO THE MARK AND MARK AGAIN HALFWAY BETWEEN.
    - 4.3.5 RE-POSITION THE GUIDE ON THE PIPE AND TAPE IN PLACE SO THAT ONE OF THE MARKS INDICATES THE CENTERLINE OF THE INSTALLED MOUNTING FRAMES AND THE MOUNTING GUIDE EDGE IS AGAINST THE END OF ONE OF THE MOUNTING FRAMES. MAKE SURE THE OVERLAPPING LENGTHS OF THE MOUNTING GUIDE ARE EDGE-ALIGNED. THIS ASSURES A DIAMETRICAL TRANSFER OF THE MOUNTING FRAME POSITION.
    - 4.3.6 LOOSEN THE MOUNTING STRAP ON THE MOUNTING FRAME WITH WHICH THE MOUNTING GUIDE HAS BEEN ALIGNED. ROTATE IT AROUND THE PIPE SURFACE UNTIL IT IS CENTERED ON THE OPPOSITE SIDE MOUNTING GUIDE. MARK MADE IN STEP 4.3.1. TIGHTEN THE STRAP. REMOVE THE MOUNTING GUIDE.
  - 4.4 IF THE PIPE SURFACE IS CLEAN AND SMOOTH, PROCEED TO TRANSDUCER INSTALLATION ON SH-3. IF PIPE SURFACE NEEDS CONDITIONING, MARK THE MOUNTING FRAME POSITION CAREFULLY, LOOSEN STRAPS AND MOVE THE MOUNTING FRAMES ASIDE. LOCALLY SMOOTH THE PIPE SURFACE IN THE MARKED AREAS USING THE ABRASIVE PAD SUPPLIED. SHIFT THE MOUNTING FRAMES BACK INTO THEIR APPROPRIATE LOCATIONS AND TIGHTEN THE MOUNTING STRAPS SECURELY. \*\* SEE SHEET 3 FOR INSTRUCTIONS TO COMPLETE TRANSDUCER INSTALLATION.

<b>CONTROLLED DRAWING</b> CHANGES TO THIS DRAWING REQUIRE RELEVANT AGENCY APPROVAL	
DR: H. Jenkins	DATE: 3/20/09
CHK: _____	DATE: _____
ENG: _____	DATE: _____
APP: _____	DATE: _____
CERTIFIED: _____	
DATE: _____	

DO NOT SCALE THIS DRAWING  
 UNLESS OTHERWISE SPECIFIED:  
 DIMENSIONS ARE IN INCHES (MM)  
 TOLERANCES ON-  
 INCHES: ± .1 (MM): ± .2

MATERIAL: \_\_\_\_\_  
 FINISH: \_\_\_\_\_

SAP MATERIAL NO.	REV
ITEM NO.	AS
DOCUMENT NO.	DS 02
1011HNS-7	
SCALE: NONE	WT.
	SHEET 2 OF 3

**SIEMENS**  
 Siemens Energy & Automation, Inc.  
 Process Instrumentation Business Unit  
 CoC Ultrasonic Flow - Hauppauge, Long Island, NY 11788

**INSTALLATION, 1011HNS SERIES DEDICATED PLASTIC BODY TRANSDUCER**

**MATING 1012CNF SERIES TRANSDUCER CABLES WITH 1011HNF SERIES TRANSDUCERS**

- d) REMOVE PROTECTIVE CAPS.
- b) SEE APPROPRIATE CABLE ASSEMBLY DRAWING FOR 'F' CONNECTOR, NPT ADAPTER AND GLAND ASSEMBLY DETAIL.
- c) MATE 'F' CONNECTORS, CABLES TO TRANSDUCER.
- d) FOR BEST WEATHER SEAL, WRAP TEFLON PIPE TAPE (NOT SUPPLIED) AROUND MALE NPT THREADS ON TRANSDUCER HOUSING.
- e) SCREW NPT ADAPTER TO TRANSDUCER HOUSING (HAND TIGHT IS SUFFICIENT).
- f) TIGHTEN GLAND BODY, WITH NPT ADAPTER AND SECURE CABLE BY TIGHTENING GLAND TOP NUT. (HAND TIGHT IS SUFFICIENT).

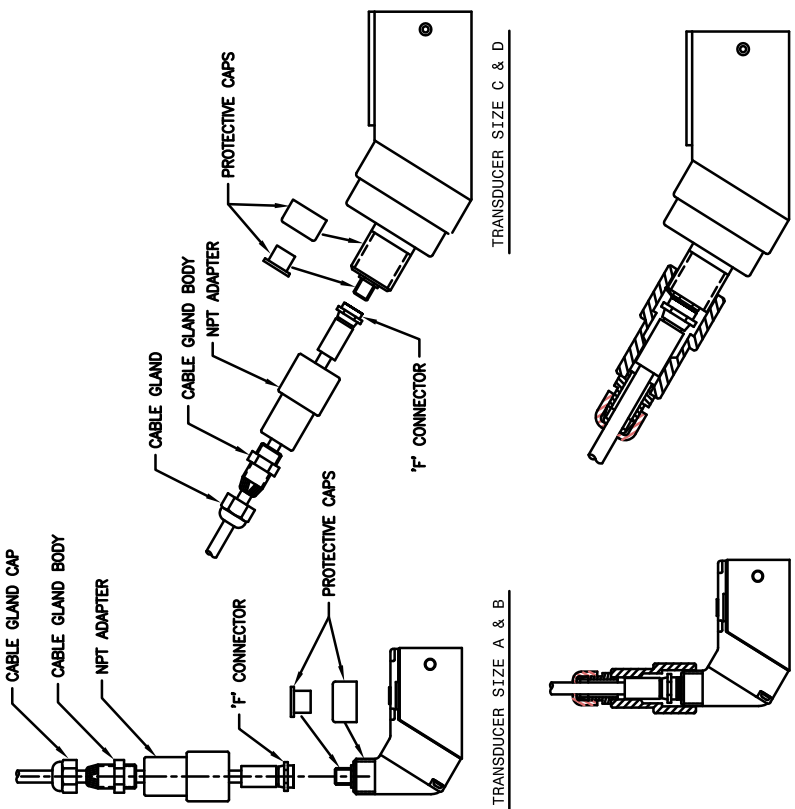

**INSTALLING TRANSDUCERS IN MOUNTING FRAMES**

APPLY A THIN BAND OF COUPLANT TO THE EMITTING SURFACE OF THE TRANSDUCERS. SLIP THE TRANSDUCERS INTO THE MOUNTING FRAMES, SEATING THEM SQUARELY ON THE PIPE SURFACE. PUSH FORWARD INTO THE FRAMES AGAINST THE FRONT SPACER. LOCATE CLAMPING SCREW IN PROPER POSITION. TIGHTEN THE TRANSDUCER CLAMPING SCREW, FIRMLY SEATING THE TRANSDUCERS ON THE PIPE SURFACE. SECURE THE CLAMPING SCREW WITH LOCK NUT.

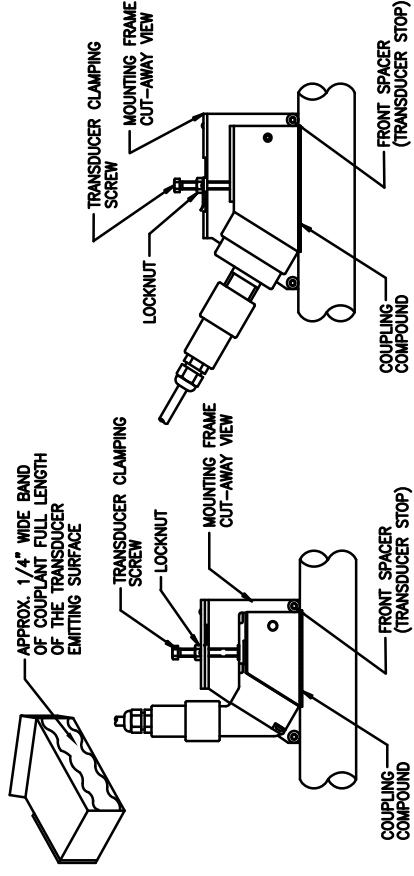

\*\*SEE DRAWING 10121HP-7 FOR INSTALLATION USING 10121HP SERIES MOUNTING TRACKS.

**USE OF FLEXIBLE CONDUIT WITH TRANSDUCERS**

THE TRANSDUCER WIRING HOUSING HAS INTEGRAL 1/2" N.P.T. THREADS TO ACCEPT A CONDUIT COUPLING IF FLEXIBLE CONDUIT IS USED. MAKE CONNECTION AS SHOWN, THEN PASS COUPLING AND CONDUIT OVER THE CABLE, SECURE TO THE TRANSDUCER WIRING HOUSING.

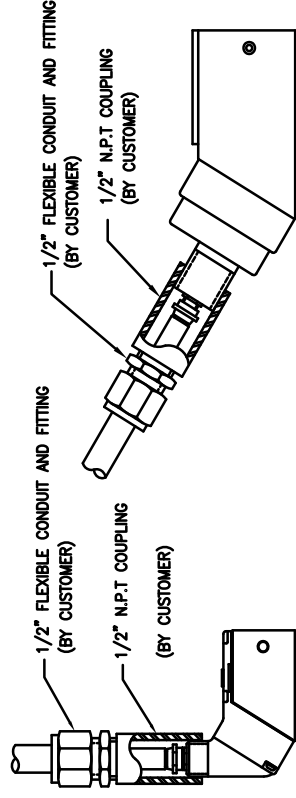

DO NOT SCALE THIS DRAWING  
UNLESS OTHERWISE SPECIFIED:  
DIMENSIONS ARE IN INCHES (MM)  
TOLERANCES ON-

INCHES (MM)  
± .1 (MM) ± .2

MATERIAL:

FINISH:

CONTROLLED DRAWING  
CHANGES TO THIS DRAWING REQUIRE  
RELEVANT AGENCY APPROVAL

DR	H. J. J. J.	DATE	5/20/09
CHK		DATE	
ENG		DATE	
PRD		DATE	
APPD		DATE	
CERTIFIED			
DATE			

**SIEMENS**  
Siemens Energy & Automation, Inc.  
Process Instrumentation Business Unit  
CoC Ultrasonic Flow - Hauppauge, Long Island, NY 11788

INSTALLATION, 1011HNF SERIES  
DEDICATED PLASTIC BODY  
TRANSDUCER

SIZE	SAP MATERIAL NO.	REV
C	ITEM NO.	AS
	DOCUMENT NO.	1011HNF5-7
	SCALE: NONE	WT.
		SHEET 3 OF 3

**INSTALLATION NOTES - CONT'D FROM SHIT. 1 OR SHIT. 2**

- 5. MAKE CABLE CONNECTIONS AT FLOW COMPUTER IN ACCORDANCE WITH APPROPRIATE FLOW COMPUTER INSTALLATION DRAWING AND 1010 FIELD MANUAL.
- 6. SEE DRAWINGS 1012FNH-B AND 1011HNF5-B FOR MOUNTING FRAME AND TRANSDUCER OUTLINE DIMENSIONS.

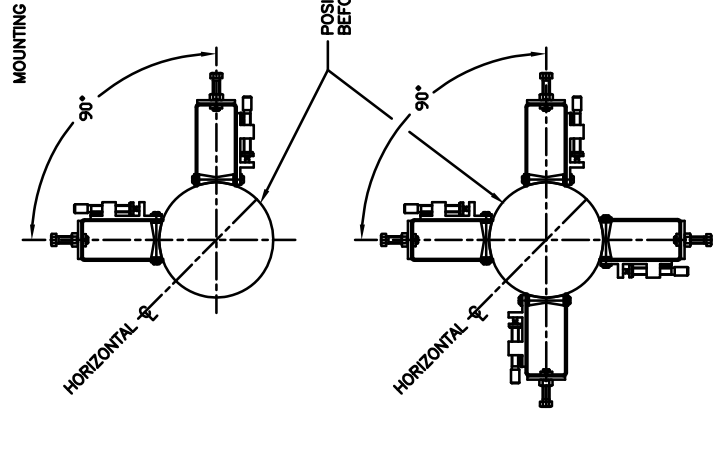
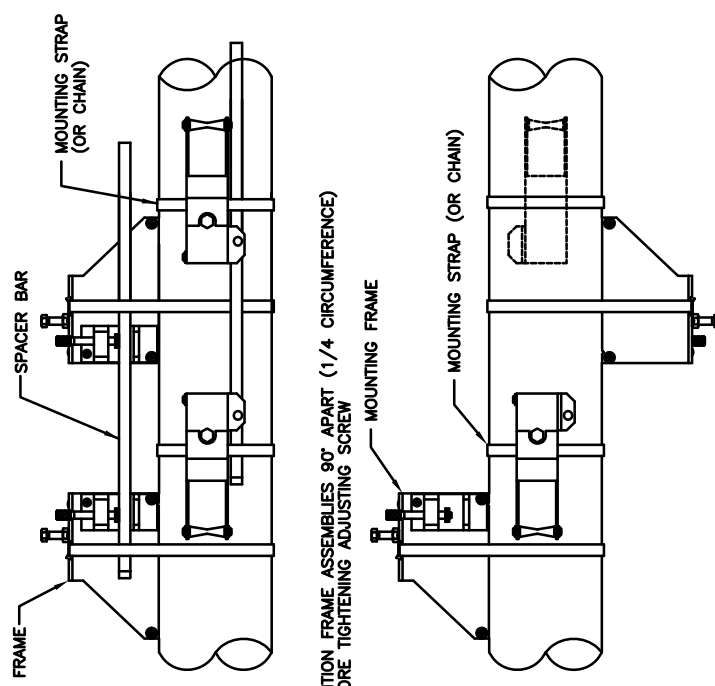

**NOTES:**

1. USING THE INSTALLATION MENU AND THE PROCEDURE OUTLINED IN THE FIELD MANUAL, SELECT THE APPROPRIATE TRANSDUCERS AND MOUNTING FRAMES FOR THE MODE OF OPERATION CHOSEN FOR YOUR APPLICATION. REFLECT MODE IS PREFERRED.
2. SELECT MOUNTING LOCATION:
  - a) TRANSDUCER SETS SHOULD BE MOUNTED SO THAT THE PLANES OF OPERATION OF THE TWO SETS INTERSECT ORTHOGONALLY; THAT IS, 90° OR 1/4 THE CIRCUMFERENCE OF THE PIPE APART.
  - b) CHOOSE A LOCATION WHICH REMAINS FULL AT ZERO FLOW ON HORIZONTAL PIPES. MOUNT AWAY FROM THE UNDERSIDE TO AVOID SEDIMENT BLOCKAGE OR ULTRASONIC BEAM, MOUNT AWAY FROM TOPSIDE TO AVOID BLOCKAGE DUE TO ENTRAPPED AIR.
  - c) WHERE POSSIBLE, LOCATE MOUNTING FRAME ASSEMBLIES AS FAR AS POSSIBLE DOWNSTREAM FROM ANY FLOW DISTURBANCE TO ASSURE FULLY DEVELOPED AND STABLE FLOW PROFILE.
3. MOUNT FRAMES ON PIPE:
  - a) REFER TO THE APPROPRIATE INSTALLATION DRAWING FOR THE PORTABLE OR DEDICATED TRANSDUCERS AND FRAMES SELECTED FOR USE. NOTE THESE DRAWINGS PROVIDE INSTRUCTIONS FOR SINGLE PATH INSTALLATIONS. DUAL PATH SYSTEMS ARE INSTALLED IN THE SAME FASHION BY OFFSETTING A SECOND SET OF MOUNTING FRAMES IN AN ORTHOGONAL PLANE AS SHOWN ABOVE.
4. CONDITION PIPE SURFACE:
 

LOCALLY SMOOTH THE PIPE SURFACE AT EACH TRANSDUCER LOCATION AND INSTALL TRANSDUCERS IN ACCORDANCE WITH THE PROCEDURE DESCRIBED ON THE APPROPRIATE TRANSDUCER AND FRAME INSTALLATION DRAWING. MAKE SURE THAT TRANSDUCER PAIRS ARE INSTALLED AND CONNECTED TO THE FLOW COMPUTER CORRECTLY.
5. REFER TO THE APPROPRIATE OUTLINE DRAWINGS FOR TRANSDUCER AND MOUNTING FRAME OUTLINE DIMENSIONS.

		<b>INSTALLATION DRAWING</b> <b>DUAL PATH TRANSDUCER SET</b> <b>WITH MOUNTING FRAMES</b>		REV. <b>B</b>	
DO NOT SCALE THIS DRAWING UNLESS OTHERWISE SPECIFIED. DIMENSIONS ARE IN INCHES UNLESS OTHERWISE SHOWN.		CONTRACT NO. IR H.J. DATE 9/10/98	SIZE CODE IDENT NO. <b>C 21614</b>	SCALE: NONE   WT.	SHEET 1 OF 1
CHK _____ DATE _____ ENG _____ DATE _____ PRD _____ DATE _____ APPD _____ DATE _____ CERTIFIED _____	DATE _____	1012F-DB-7	R14: 1012F-DB-7 sht.1 rev.B 1 CN#4344		





BAND LENGTH TABLE	
PIPE DIA.	LENGTH TO CUT ON MARK
48"	167-5/16"
50"	173-9/16"
52"	177-7/8"
54"	180-3/16"
56"	186-7/16"
58"	188-3/4"
60"	195"
84"	267-3/8"
120"	380-1/2"

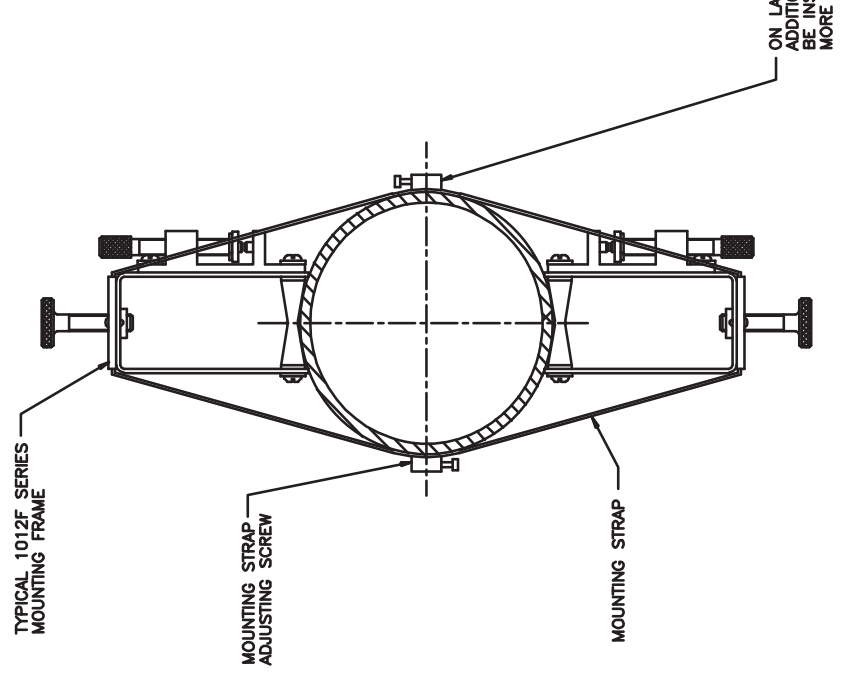

**NOTES:**  
 1. BAND LENGTHS ARE APPROXIMATE AND CALCULATED FOR USE OF SIZE "D" OR "E" 1011 TRANSDUCERS.

INSTALLATION / OUTLINE ADJUSTABLE MOUNTING STRAP	
SIZE: <b>C</b> CODE IDENT NO: <b>21614</b>	REV: <b>F</b> 1012MS - 8
SCALE: NONE VT.	SHEET 2 OF 2

**STEP - 1**  
 DETERMINE PROPER BAND LENGTH ONE OF TWO WAYS:  
 A) IF DIAMETER IS KNOWN, REFER TO BAND LENGTH TABLE OR CALCULATE MAXIMUM BAND LENGTH 3.14 x DIA. + 18", TRIM TO FIT WHEN INSTALLING.  
 B) IF DIAMETER IS NOT KNOWN, MEASURE CIRCUMFERENCE WITH STRING, TWINE, etc., AND ADD 18" (TO ENCIRCLE FRAMES). THIS DIMENSION IS APPROXIMATE, TRIM BAND TO FIT WHEN INSTALLING.

**STEP - 2**  
 MEASURE BAND TO PROPER LENGTH AND CUT THROUGH CENTER OF NEAREST ROUND HOLE WITH SHEARS, SNIPS, HACKSAW etc.

**STEP - 3**  
 EITHER MATE FASTENER HALVES AND THEN LINK TO STRAP ALREADY IN PLACE AROUND PIPE, OR LINK FASTENER HALVES INDEPENDENTLY TO STRAP ENDS (HOLD IN PLACE WITH TAPE IF NECESSARY) AND ENGAGE FASTENER AFTER WRAPPING STRAP AROUND PIPE.

**STEP - 4**  
 USING STRAPS MADE TO SIZE REQUIRED, INSTALL MOUNTING TRACKS AND TRANSDUCERS IN ACCORDANCE WITH APPROPRIATE INSTALLATION DRAWING FOR SPECIFIC TRACK ASSEMBLIES.

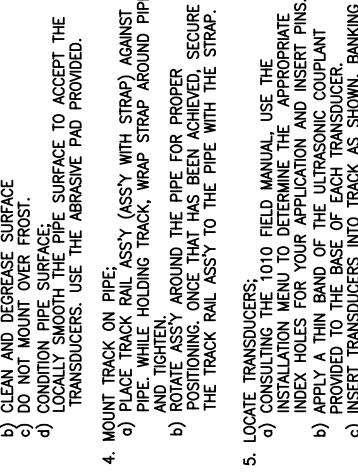
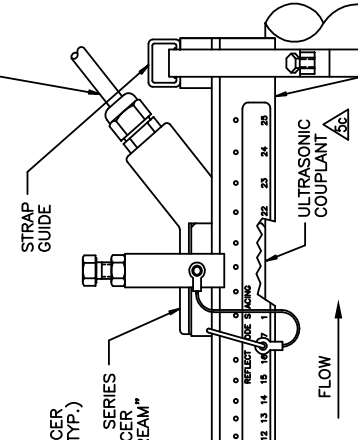
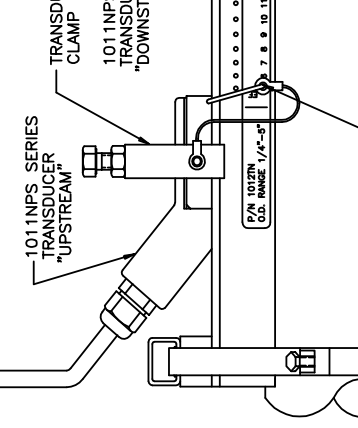
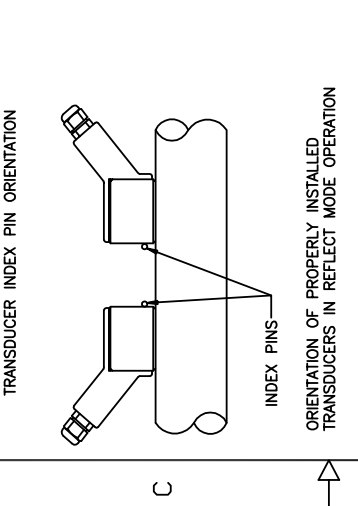
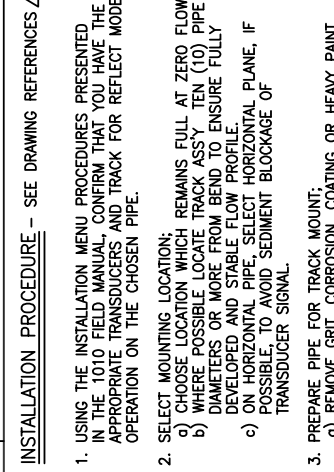
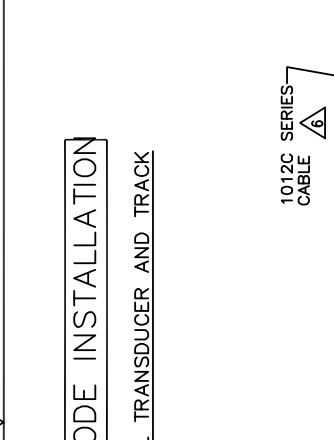
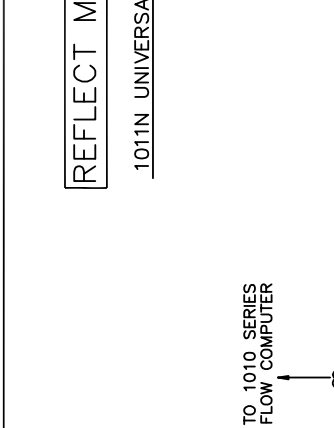
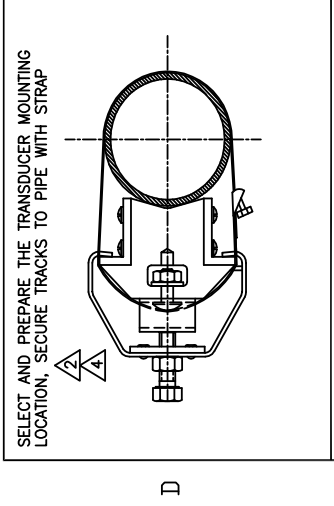

1. USING THE INSTALLATION MENU PROCEDURES PRESENTED IN THE 1010 FIELD MANUAL, CONFIRM THAT YOU HAVE THE APPROPRIATE TRANSDUCERS AND TRACK FOR REFLECT MODE OPERATION ON THE CHOSEN PIPE.
2. SELECT MOUNTING LOCATION:
  - a) CHOOSE LOCATION WHICH REMAINS FULL AT ZERO FLOW.
  - b) WHERE POSSIBLE, LOCATE TRACK ASSY. TEN (10) PIPE DIAMETERS OR MORE FROM BEND TO ENSURE FULLY DEVELOPED AND STABLE FLOW PROFILE.
  - c) ON HORIZONTAL PIPE, SELECT HORIZONTAL PLANE, IF POSSIBLE; TO AVOID SEDIMENT BLOCKAGE OF TRANSDUCER SIGNAL.
3. PREPARE PIPE FOR TRACK MOUNT:
  - a) REMOVE GRIT, CORROSION, COATING OR HEAVY PAINT
  - b) CLEAN AND DEGREASE SURFACE
  - c) DO NOT MOUNT OVER FROST.
  - d) CONDITION PIPE SURFACE:
    - i) LOCALLY SMOOTH THE PIPE SURFACE TO ACCEPT THE TRANSDUCERS. USE THE ABRASIVE PAD PROVIDED.
4. MOUNT TRACK ON PIPE:
  - a) PLACE TRACK RAIL ASSY (ASSY WITH STRAP) AGAINST PIPE WHILE HOLDING TRACK, WRAP STRAP AROUND PIPE AND TIGHTEN.
  - b) ROTATE ASSY AROUND THE PIPE FOR PROPER POSITIONING. ONCE THAT HAS BEEN ACHIEVED, SECURE THE TRACK RAIL ASSY TO THE PIPE WITH THE STRAP.
5. LOCATE TRANSDUCERS:
  - a) CONSULTING THE 1010 FIELD MANUAL, USE THE INSTALLATION MENU TO DETERMINE THE APPROPRIATE INDEX HOLES FOR YOUR APPLICATION AND INSERT PINS.
  - b) APPLY A THIN BAND OF THE ULTRASONIC COUPLANT PROVIDED TO THE BASE OF EACH TRANSDUCER.
  - c) INSERT TRANSDUCERS INTO TRACK AS SHOWN, BANKING AGAINST INDEX PINS. SECURE TRANSDUCERS WITH CLAMPS.
6. MAKE TRANSDUCER CABLE CONNECTIONS IN ACCORDANCE WITH THE APPROPRIATE FLOW COMPUTER INSTALLATION DRAWING AND 1010 FIELD MANUAL.
7. SEE DRAWING 1012TN-8 AND 1011NPS-8 FOR TRACK AND TRANSDUCER OUTLINE DIMENSIONS.

<b>INSTALLATION DRAWING</b> <b>1010 SERIES TRANSDUCERS</b> <b>AND MOUNTING TRACKS</b>	
SIZE <b>C 21614</b>	CODE IDENT NO. <b>1012TN-7</b>
SCALE: NONE	WT.
SHEET 1 OF 2	R14: 1012TN-7A rev.A

DO NOT SCALE THIS DRAWING UNLESS OTHERWISE SPECIFIED, DIMENSIONS ARE IN INCHES (IMP) TOLERANCES ON— INCHES +/-.1 (MM) +/-.2	CONTRACT NO. H.J. DATE 6/10/98 CHK. DATE ENG. DATE PRD. DATE APPD. DATE CERTIFIED
--	---

DATE	2
DATE	3

DATE	4
------	---



**DIRECT MODE INSTALLATION**

**1011N UNIVERSAL TRANSDUCER AND TRACK**

INSTALLATION PROCEDURE - SEE DRAWING REFERENCES A

1. USING THE INSTALLATION MENU, PROCEDURES PRESENTED IN THE 1010 FIELD MANUAL, CONFIRM THAT YOU HAVE THE APPROPRIATE TRANSDUCERS AND TRACK FOR DIRECT MODE OPERATION ON THE CHOSEN PIPE.
2. SELECT MOUNTING LOCATION:
  - a) CHOOSE LOCATION WHICH REMAINS FULL AT ZERO FLOW.
  - b) WHERE POSSIBLE LOCATE TRACK ASSY TEN (10) PIPE DIAMETERS OR MORE FROM BEND TO ENSURE FULLY DEVELOPED AND STABLE FLOW PROFILE.
  - c) ON HORIZONTAL PIPE, SELECT HORIZONTAL PLANE IF POSSIBLE, TO AVOID SEDIMENT BLOCKAGE OF TRANSDUCER SIGNAL.
3. PREPARE PIPE FOR TRACK MOUNT:
  - a) REMOVE GRIT, CORROSION, COATING OR HEAVY PAINT
  - b) CLEAN AND DEGRADE SURFACE
  - c) DO NOT MOUNT OVER FROST.
  - d) CONDITION PIPE SURFACE.
4. MOUNT TRACK ON PIPE:
  - a) PLACE TRACK RAIL ASSY (ASSY WITH STRAP) AGAINST PIPE. WHILE HOLDING TRACK, PLACE THE SECOND TRACK ONTO THE PIPE AND HOLD TOGETHER IN PLACE.
  - b) ROTATE ASSY AROUND THE PIPE FOR PROPER POSITIONING. ONCE THAT HAS BEEN ACHIEVED, SECURE THE TRACK RAIL ASSY TO THE PIPE WITH THE STRAP.
5. LOCATE TRANSDUCERS:
  - a) CONSULTING THE 1010 FIELD MANUAL, USE THE INSTALLATION MENU TO DETERMINE THE APPROPRIATE INDEX HOLES FOR YOUR APPLICATION AND INSERT PINS.
  - b) APPLY A THIN BAND OF THE ULTRASONIC COUPLANT PROVIDED TO THE BASE OF EACH TRANSDUCER.
  - c) INSERT TRANSDUCERS INTO TRACK AS SHOWN, BANKING AGAINST INDEX PINS. SECURE TRANSDUCERS WITH CLAMPS.
6. MAKE TRANSDUCER CABLE CONNECTIONS IN ACCORDANCE WITH THE APPROPRIATE FLOW COMPUTER INSTALLATION DRAWING AND 1010 FIELD MANUAL.
7. SEE DRAWING 1012TN-8 AND 1011NPS-8 FOR TRACK AND TRANSDUCER OUTLINE DIMENSIONS.

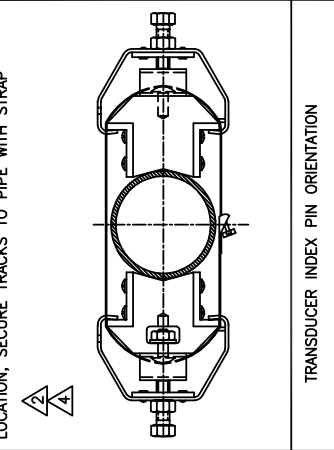

SELECT AND PREPARE THE TRANSDUCER MOUNTING LOCATION, SECURE TRACKS TO PIPE WITH STRAP

TRANSDUCER INDEX PIN ORIENTATION

ORIENTATION OF PROPERLY INSTALLED TRANSDUCERS IN DIRECT MODE OPERATION

CONDITION PIPE SURFACE AT THE TRANSDUCER MOUNTING LOCATION USING THE ABRASIVE PAD SUPPLIED.

**ONTROLOTRON**  
HAUPPAUGE, NY 11788

**INSTALLATION DRAWING**  
**1010 SERIES TRANSDUCERS**  
**AND MOUNTING TRACKS**

DO NOT SCALE THIS DRAWING  
UNLESS OTHERWISE SPECIFIED.  
DIMENSIONS ARE IN INCHES (MM)  
TOLERANCES IN-  
INCHES (MM)  
+/- .1 (+/- .2)

CONTRACT NO.

DATE 6/10/98

IR H,J

CHK

ENG

PRD

APPD

CERTIFIED

DATE

SCALE: NONE

WT.

SIZE CODE IDENT NO. C 21614

1012TN-7

REV. A

SHEET 2 OF 2

R14: 1012TN-7B rev.A

# REFLECT MODE INSTALLATION

## 1011HN HIGH PRECISION TRANSDUCER AND TRACK

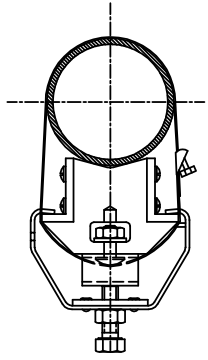
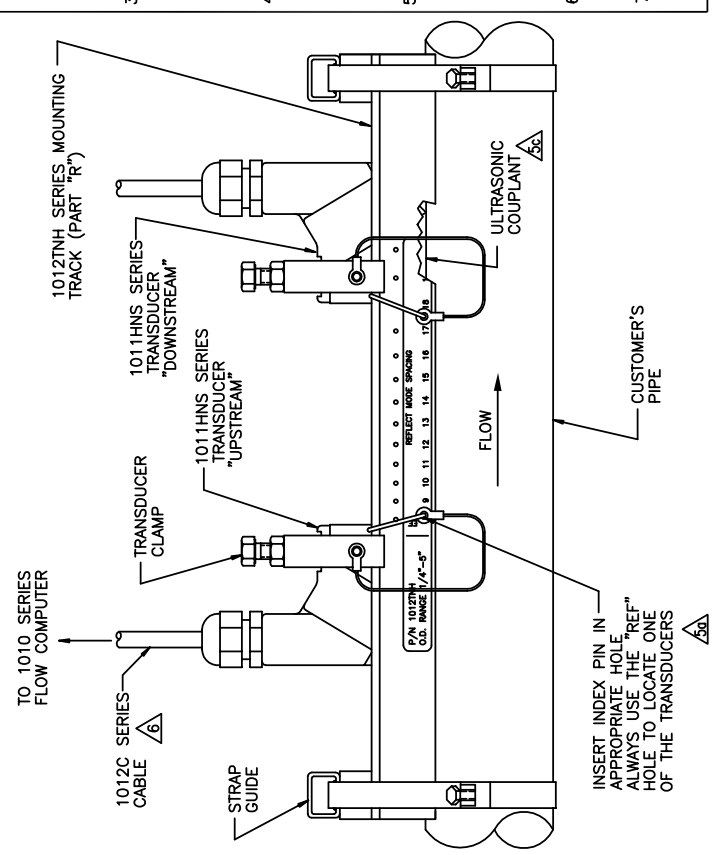

SELECT AND PREPARE THE TRANSDUCER MOUNTING LOCATION, SECURE TRACKS TO PIPE WITH STRAP

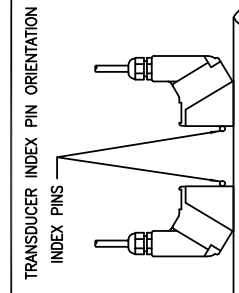

TRANSDUCER INDEX PIN ORIENTATION

ORIENTATION OF PROPERLY INSTALLED TRANSDUCERS IN REFLECT MODE OPERATION

CONDITION PIPE SURFACE AT THE TRANSDUCER MOUNTING LOCATION USING THE ABRASIVE PAD SUPPLIED.

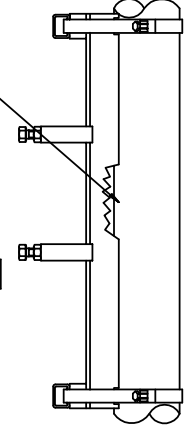

- INSTALLATION PROCEDURE - SEE DRAWING REFERENCES**
1. USING THE INSTALLATION MENU PROCEDURES PRESENTED IN THE 1010 FIELD MANUAL, CONFIRM THAT YOU HAVE THE APPROPRIATE TRANSDUCERS AND TRACK FOR REFLECT MODE OPERATION ON THE CHOSEN PIPE.
    - a) CHOOSE LOCATION WHICH REMAINS FULL AT ZERO FLOW.
    - b) WHERE POSSIBLE, LOCATE TRACK ASSY. TEN (10) PIPE DIAMETERS OR MORE FROM BEND, TO ENSURE FULLY DEVELOPED AND STABLE FLOW PROFILE.
    - c) ON HORIZONTAL PIPE, SELECT HORIZONTAL PLANE, IF POSSIBLE; TO AVOID SEDIMENT BLOCKAGE OF TRANSDUCER SIGNAL.
  2. PREPARE PIPE FOR TRACK MOUNT:
    - a) REMOVE GRIT, CORROSION, COATING OR HEAVY PAINT
    - b) CLEAN AND DECREASE SURFACE
    - c) DO NOT MOUNT OVER FROST.
    - d) CONDITION PIPE SURFACE.
  3. MOUNT TRACK ON PIPE.
    - a) PLACE TRACK RAIL ASSY (ASSY WITH STRAP) AGAINST PIPE. WHILE HOLDING TRACK, WRAP STRAP AROUND PIPE AND TIGHTEN.
    - b) ROTATE ASSY AROUND THE PIPE FOR PROPER POSITIONING. ONCE THAT HAS BEEN ACHIEVED, SECURE THE TRACK RAIL ASSY TO THE PIPE WITH THE STRAP.
  4. LOCATE TRANSDUCERS:
    - a) CONSULTING THE 1010 FIELD MANUAL, USE THE INSTALLATION MENU TO DETERMINE THE APPROPRIATE INDEX HOLES FOR YOUR APPLICATION AND INSERT PINS.
    - b) APPLY A THIN BAND OF THE ULTRASONIC COUPLANT PROVIDED TO THE BASE OF EACH TRANSDUCER.
    - c) INSERT TRANSDUCERS INTO TRACK AS SHOWN, BANKING AGAINST INDEX PINS. SECURE TRANSDUCERS WITH CLAMPS.
  5. MAKE TRANSDUCER CABLE CONNECTIONS IN ACCORDANCE WITH THE APPROPRIATE FLOW COMPUTER INSTALLATION DRAWING AND 1010 FIELD MANUAL.
  7. SEE DRAWING 1012TNH-8 AND 1011HNS-8 FOR TRACK AND TRANSDUCER OUTLINE DIMENSIONS.

**CONTROLTRON**  
HAUPPAUGE, NY 11788

**INSTALLATION DRAWING**  
**1010 SERIES TRANSDUCERS**  
**AND MOUNTING TRACKS**

SIZE: **C 21614**    CODE IDENT NO: **1012TNH-7**    REV. **A**

SCALE: NONE    WT.    SHEET 1 OF 2

CONTRACT NO.		DATE	6/10/98
DR	H.J.	DATE	
CHK		DATE	
ENG		DATE	
PRD		DATE	
APPD		DATE	
CERTIFIED		DATE	

UNLESS OTHERWISE SPECIFIED, DIMENSIONS ARE IN INCHES (MM) TOLERANCES IN: INCHES +/- .1 (MM) +/- .2

4 3 2 1

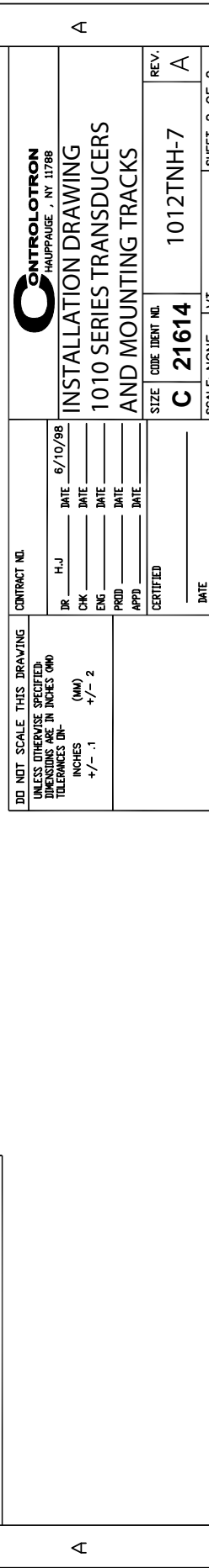
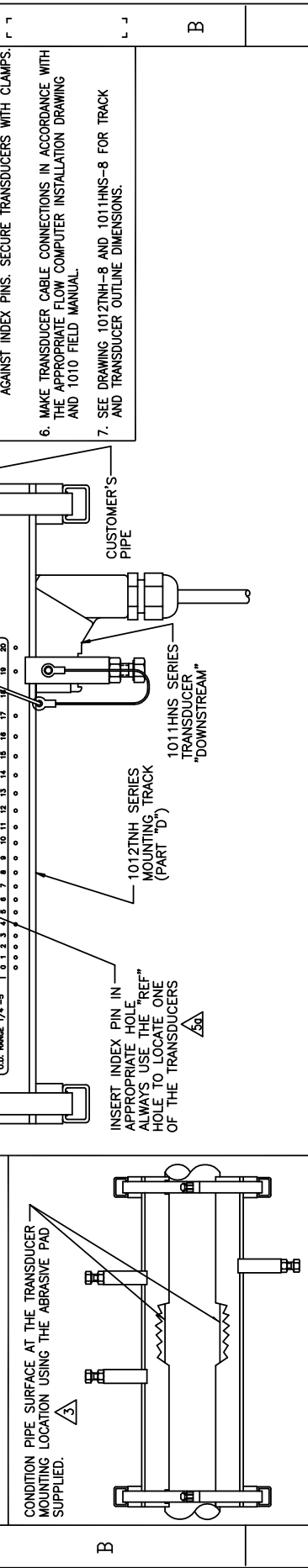
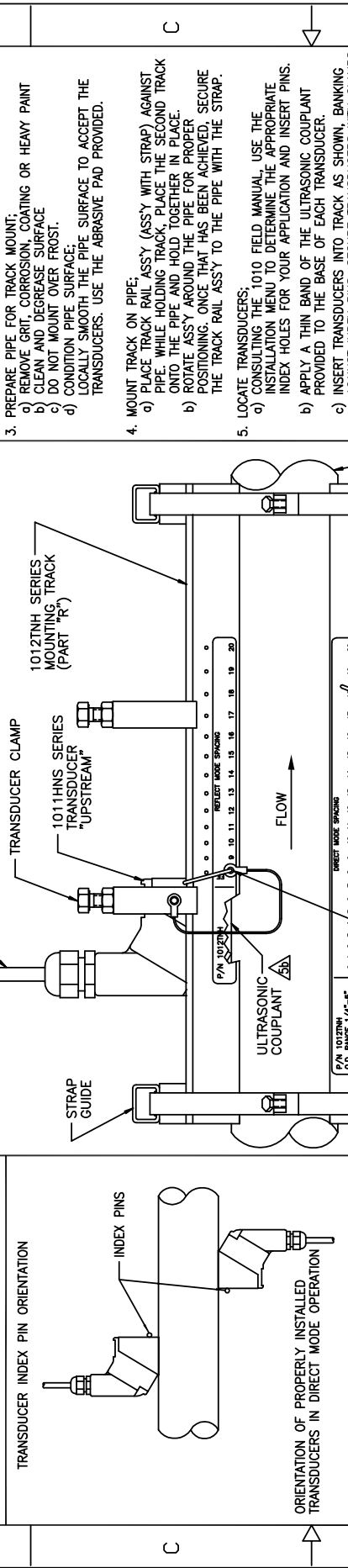
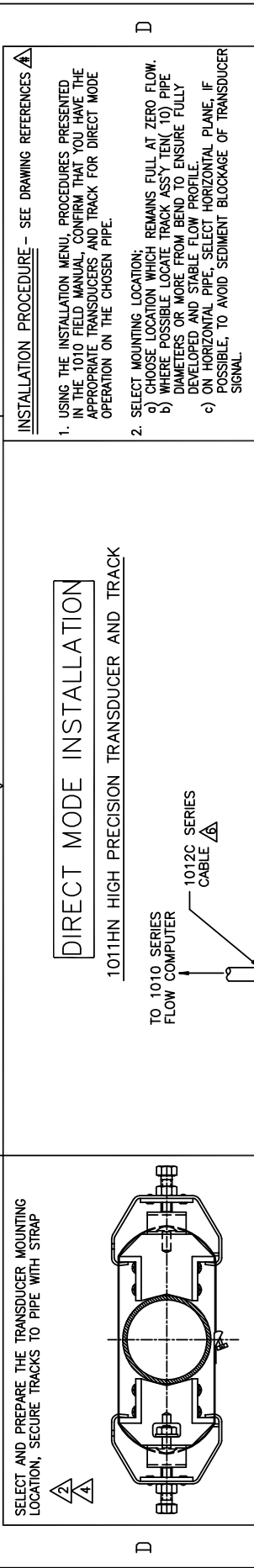

- INSTALLATION PROCEDURE - SEE DRAWING REFERENCES**
- USING THE INSTALLATION MENU, PROCEDURES PRESENTED IN THE 1010 FIELD MANUAL, CONFIRM THAT YOU HAVE THE APPROPRIATE TRANSDUCERS AND TRACK FOR DIRECT MODE OPERATION ON THE CHOSEN PIPE.
  - SELECT MOUNTING LOCATION:
    - CHOOSE LOCATION WHICH REMAINS FULL AT ZERO FLOW.
    - WHERE POSSIBLE LOCATE TRACK ASSY TEN (10) PIPE DIAMETERS OR MORE FROM BEND TO ENSURE FULLY DEVELOPED AND STABLE FLOW PROFILE.
    - ON HORIZONTAL PIPE, SELECT HORIZONTAL PLANE, IF POSSIBLE, TO AVOID SEDIMENT BLOCKAGE OF TRANSDUCER SIGNAL.
  - PREPARE PIPE FOR TRACK MOUNT:
    - REMOVE GRIT, CORROSION, COATING OR HEAVY PAINT
    - CLEAN AND DEGREASE SURFACE
    - DO NOT MOUNT OVER FROST.
    - CONDITION PIPE SURFACE:
      - LOCALLY SMOOTH THE PIPE SURFACE TO ACCEPT THE TRANSDUCERS. USE THE ABRASIVE PAD PROVIDED.
  - MOUNT TRACK ON PIPE;
    - PLACE TRACK RAIL ASSY (ASSY WITH STRAP) AGAINST PIPE. WHILE HOLDING TRACK, PLACE THE SECOND TRACK ONTO THE PIPE AND HOLD TOGETHER IN PLACE.
    - ROTATE ASSY AROUND THE PIPE FOR PROPER POSITIONING. ONCE THAT HAS BEEN ACHIEVED, SECURE THE TRACK RAIL ASSY TO THE PIPE WITH THE STRAP.
  - LOCATE TRANSDUCERS;
    - CONSULTING THE 1010 FIELD MANUAL, USE THE INSTALLATION MENU TO DETERMINE THE APPROPRIATE INDEX HOLES FOR YOUR APPLICATION AND INSERT PINS.
    - APPLY A THIN BAND OF THE ULTRASONIC COUPLANT PROVIDED TO THE BASE OF EACH TRANSDUCER.
    - INSERT TRANSDUCERS INTO TRACK AS SHOWN, BANKING AGAINST INDEX PINS. SECURE TRANSDUCERS WITH CLAMPS.
  - MAKE TRANSDUCER CABLE CONNECTIONS IN ACCORDANCE WITH THE APPROPRIATE FLOW COMPUTER INSTALLATION DRAWING AND 1010 FIELD MANUAL.
  - SEE DRAWING 1012TNH-8 AND 1011HNS-8 FOR TRACK AND TRANSDUCER OUTLINE DIMENSIONS.

<b>CONTROLTRON</b> HAUPPAUGE, NY 11788	
<b>INSTALLATION DRAWING</b>	
<b>1010 SERIES TRANSDUCERS</b>	
<b>AND MOUNTING TRACKS</b>	
SIZE	CODE IDENT. NO.
<b>C 21614</b>	<b>1012TNH-7</b>
SCALE: NONE	WT.
REV.	A
SHEET 2 OF 2	1

4 3 2 1

- STEP - 1**  
 DETERMINE PROPER BAND LENGTH ONE OF TWO WAYS:  
 A) IF DIAMETER IS KNOWN, REFER TO BAND LENGTH TABLE OR CALCULATE BAND LENGTH =  $3.14 \times \text{DIA} - 3.5"$   
 B) IF DIAMETER IS NOT KNOWN, MEASURE CIRCUMFERENCE INDEPENDENTLY TO STRAP ENDS (HOLD IN PLACE WITH TAPE IF NECESSARY) AND ENGAGE FASTENER AFTER WRAPPING STRAP AROUND PIPE.
- STEP - 2**  
 MEASURE BAND TO PROPER LENGTH AND CUT THROUGH CENTER OF NEAREST ROUND HOLE WITH SHEARS, SNIPS, HACKSAW etc.
- STEP - 3**  
 EITHER MATE FASTENER HALVES AND THEN LINK TO STRAP ALREADY IN PLACE AROUND PIPE, OR LINK FASTENER HALVES INDEPENDENTLY TO STRAP ENDS (HOLD IN PLACE WITH TAPE IF NECESSARY) AND ENGAGE FASTENER AFTER WRAPPING STRAP AROUND PIPE.
- STEP - 4**  
 MATE "T" ON FASTENERS WITH RECTANGULAR CUT-OUT ON MOUNTING NUT ASSEMBLY. INCLUDE FIXED LENGTH STRAPS TO SIZE "T" ON MOUNTING NUT. MOUNTING NUT SIZES: 3/4", 4" MOUNTING ASSY INCLUDE A CUT-TO-FIT MOUNTING STRAP. (SEE STEP 3).

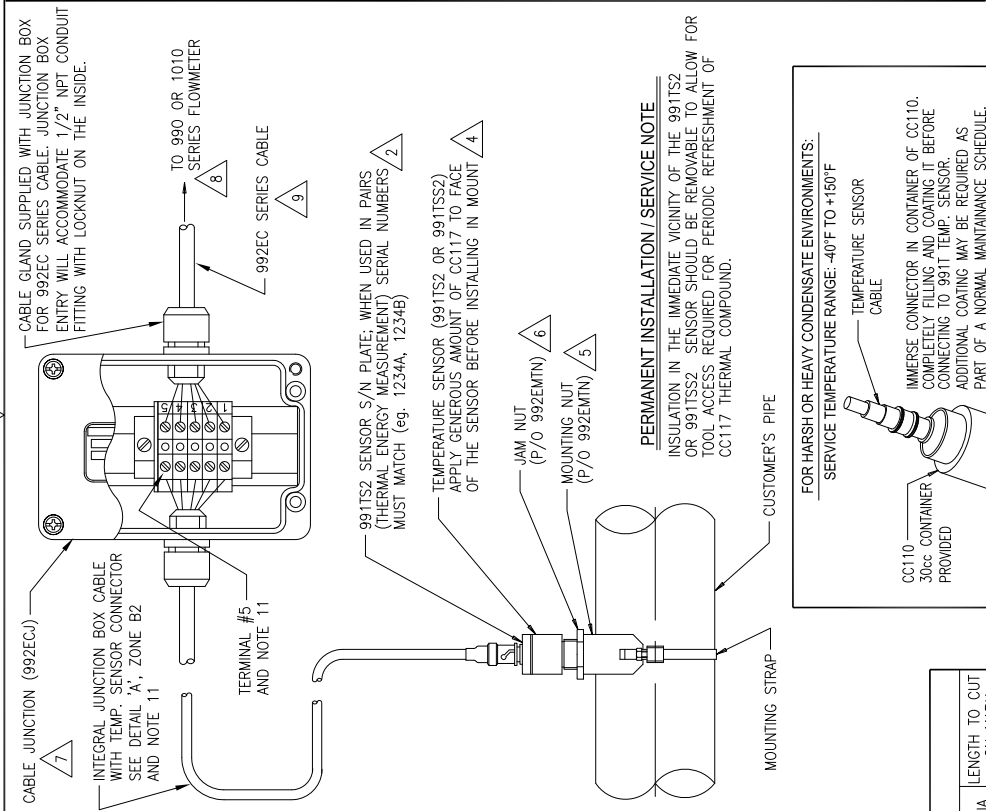

- INSTALLATION PROCEDURE** - SEE DRAWING REFERENCE  $\Delta$
- INSTALLATION OF THE DEDICATED NEMA 4 TEMPERATURE SENSOR FOR PIPES 1 1/4" - 48" DIAMETER REQUIRES THE FOLLOWING: THE SENSOR 991TSZ (OR 991TSSZ), A MOUNTING ASSY 992EMTN-2, -3, -4, AND A CABLE 992ECN-(LENGTH) IN TWO PARTS, JUNCTION 992ECJ AND CABLE 992ECC-(LENGTH). (SEE NOTE 10).
  - TEMPERATURE SENSORS ARE SUPPLIED IN PAIRS (P/O 991TSZ) FOR THERMAL ENERGY FLOWMETER APPLICATIONS OR SINGLY (P/O 991TSSZ) FOR TEMPERATURE COMPENSATED MASS FLOWMETER APPLICATIONS.
  - SELECT THE PIPE LOCATION WHERE TEMPERATURE IS TO BE MONITORED IN ACCORDANCE WITH RECOMMENDATIONS IN THE FIELD MANUAL.
  - CLEAN A SMALL AREA OF PIPE SURFACE (APPROXIMATELY 1" DIAMETER); REMOVE PAINT, SCALE, FOREIGN MATTER THAT CAN AFFECT GOOD THERMAL CONTACT.
  - CENTER THE MOUNTING NUT (PART OF 992EMTN) OVER THE CLEAN SPOT AND STRAP IN PLACE. ALLOW THE STRAP TO REACH APPROXIMATELY THE TEMPERATURE OF THE PIPE AND TIGHTEN SECURELY.
  - SPIN THE JAM NUT (PART OF 992EMTN) ONTO THE SENSOR BODY (991TSZ OR 991TSSZ); APPLY A GENEROUS AMOUNT OF THERMAL COUPLANT (SUPPLIED WITH 992EMTN) TO THE FACE OF THE SENSOR AND SCREW IT INTO THE MOUNTING NUT. HAND TIGHT ENGAGEMENT IS SUFFICIENT. SECURE THE SENSOR BY TIGHTENING THE JAM NUT AGAINST THE MOUNTING NUT.
  - SELECT A MOUNTING LOCATION FOR THE 992ECJ JUNCTION BOX. USE INTEGRAL MOUNTING FLANGES OR SECURE AT THE END OF RIGID CONDUIT. IF CONDUIT IS USED, REMOVE THE WATERTIGHT GLAND SUPPLIED WITH THE 992ECC CABLE. INSTALL THE 992ECC CABLE, MAKING WIRING CONNECTIONS 1-5 AS SHOWN.
  - MAKE CABLE CONNECTIONS TO THE 994 OR 1010 SERIES FLOWMETER IN ACCORDANCE WITH THE APPROPRIATE FLOWMETER INSTALLATION DRAWING.
  - STANDARD TEMPERATURE SENSOR CABLE AND JUNCTION BOX ARE PART NUMBERS 992ECC-(LENGTH) AND 992ECJ RESPECTIVELY. FOR PLENUM RATED CABLE ASSEMBLIES, USE CABLE AND JUNCTION BOX PART NUMBERS 992ECCD-(LENGTH) AND 992ECJD.
  - SEE DRAWING 991TS2-8 FOR OUTLINE DIMENSIONS.
  - IF NECESSARY, TO ISOLATE RTD BODY FROM FLOW METER GROUND, DISCONNECT TERMINAL #5 AND TAPE BACK TO PREVENT ELECTRICAL CONTACT. THIS GROUND ISOLATION DOES NOT AFFECT SAFETY.

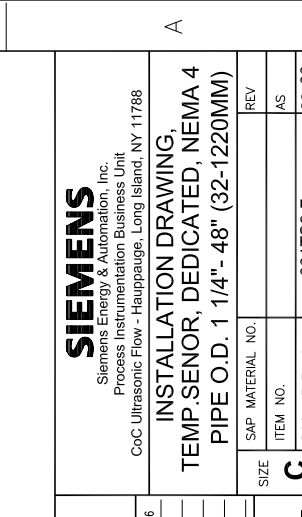

**BAND LENGTH TABLE**

PIPE DIA.	LENGTH TO CUT ON MARK	PIPE DIA.	LENGTH TO CUT ON MARK
6"	14-3/16"	16"	45-7/8"
7"	16-3/4"	17"	48-7/16"
8"	20-1/2"	18"	52-1/8"
9"	23-1/8"	19"	54-3/4"
10"	26-7/8"	20"	58-1/2"
11"	29-3/8"	22"	64-7/8"
12"	33-5/16"	24"	71-1/8"
13"	33-3/4"	26"	76-1/4"
14"	39-1/2"	28"	85-5/8"
15"	42-1/16"	30"	88-7/8"

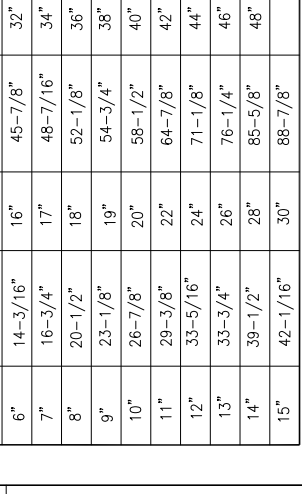

1 2 3 4

**SIEMENS**  
 Siemens Energy & Automation, Inc.  
 Process Instrumentation Business Unit  
 CoC Ultrasonic Flow - Hauppaugus, Long Island, NY 11788

**INSTALLATION DRAWING, NEMA 4 TEMP. SENSOR, DEDICATED, NEMA 4 PIPE O.D. 1 1/4" - 48" (32-1220MM)**

SIZE	SAP MATERIAL NO.	REV
C	ITEM NO.	AS
DOCUMENT NO.	991TS2-7	DS 03
SCALE: NONE	WT.	SHEET 1 OF 1

**STEP - 1**  
 DETERMINE PROPER BAND LENGTH ONE OF TWO WAYS:  
 A) IF DIAMETER IS KNOWN, REFER TO BAND LENGTH TABLE  
 B) IF DIAMETER IS NOT KNOWN, MEASURE CIRCUMFERENCE  
 (WITH STRING, TWINE, ETC., AND SUBTRACT 3.5"  
 TO ALLOW LENGTH OF FASTENER) TO DETERMINE  
 PROPER BAND LENGTH.

**STEP - 2**  
 MEASURE BAND TO PROPER LENGTH AND CUT THROUGH  
 CENTER OF NEAREST ROUND HOLE WITH SHEARS, SNIPS,  
 HACKSAW etc.

**STEP - 3**  
 EITHER MATE FASTENER HALVES AND THEN LINK TO STRAP  
 ALREADY IN PLACE AROUND PIPE, OR LINK FASTENER HALVES  
 INDEPENDENTLY TO STRAP ENDS (HOLD IN PLACE WITH TAPE  
 STRAP AROUND PIPE, ENGAGE FASTENER AFTER WRAPPING  
 STRAP AROUND PIPE).

**STEP - 4**  
 MATE "T" ON FASTENERS WITH RECTANGULAR CUT-OUT ON  
 MOUNTING NUT ASSEMBLY.  
 SIZE 2 MOUNTING ASSY'S INCLUDE FIXED LENGTH STRAPS TO  
 MATE WITH FASTENERS ATTACHED TO MOUNTING NUT.  
 MATE WITH FASTENERS ATTACHED TO MOUNTING NUT.  
 MATE WITH FASTENERS ATTACHED TO MOUNTING NUT.  
 MOUNTING STRAP (SEE STEP 3).

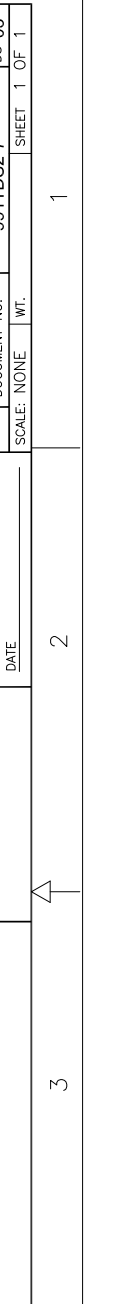
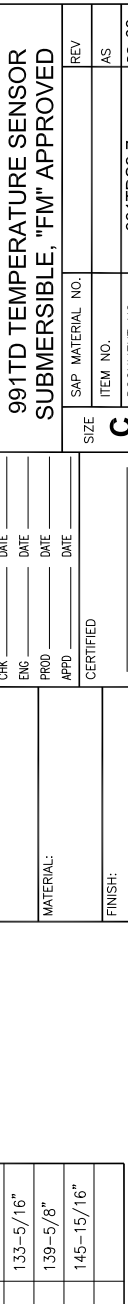
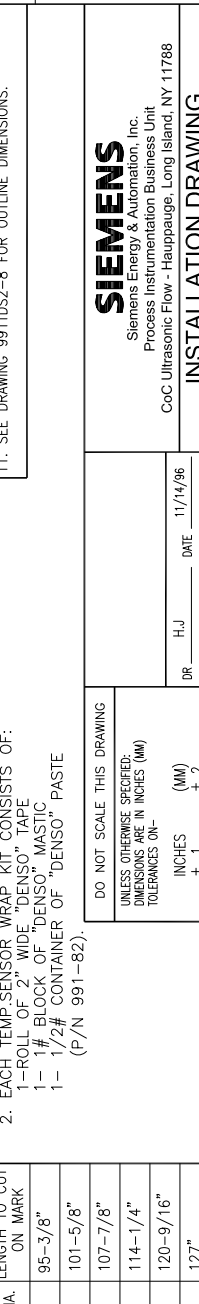
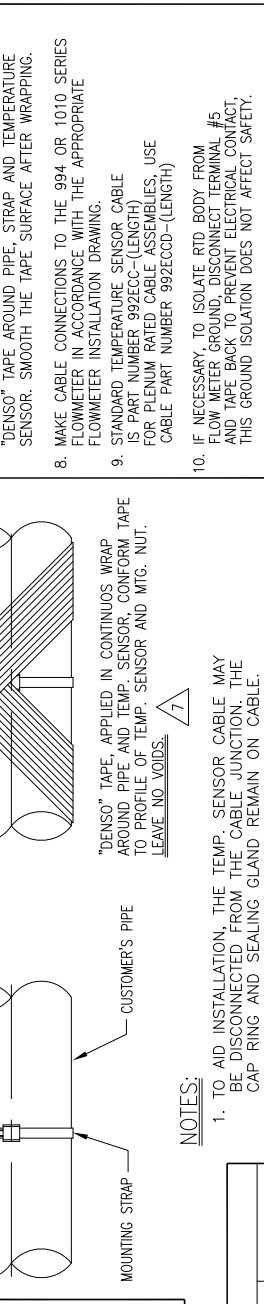
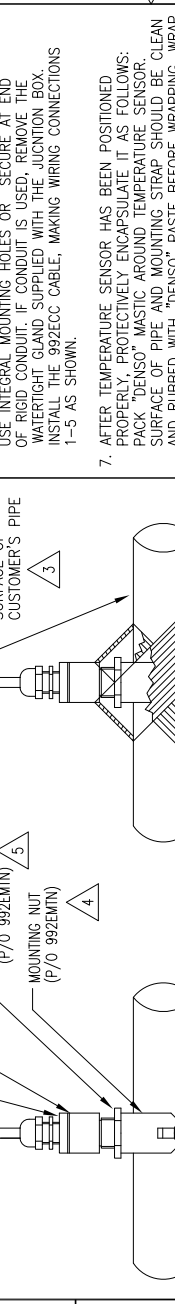
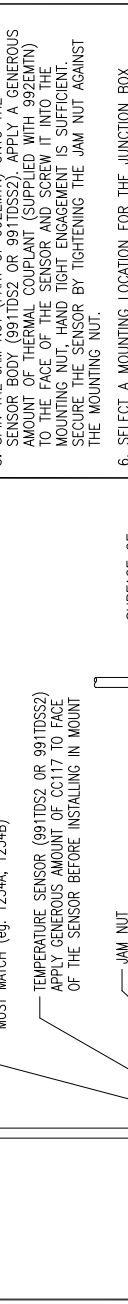
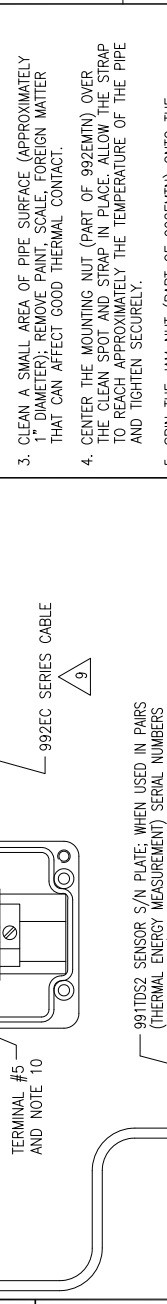

**INSTALLATION PROCEDURE** - SEE DRAWING REFERENCE **A**

- INSTALLATION OF THE DEDICATED NEMA-4 TEMPERATURE SENSOR FOR PIPES 1 1/4" - 48" DIAMETER CONSISTS OF THE FOLLOWING: THE SENSOR P/N 991TDS2/991TDS22 WITH INTEGRAL CABLE AND JUNCTION BOX, A CABLE 992ECC-(LENGTH), AND MOUNTING ASSY 992EMTN(-2,-3 OR -4).
- SELECT THE PIPE LOCATION WHERE TEMPERATURE IS TO BE MONITORED IN ACCORDANCE WITH RECOMMENDATIONS IN THE FIELD MANUAL.
- CLEAN A SMALL AREA OF PIPE SURFACE (APPROXIMATELY 1" DIAMETER); REMOVE PAINT, SCALE, FOREIGN MATTER THAT CAN AFFECT GOOD THERMAL CONTACT.
- CENTER THE MOUNTING NUT (PART OF 992EMTN) OVER THE CLEAN SPOT AND STRAP IN PLACE. ALLOW THE STRAP TO REACH APPROXIMATELY THE TEMPERATURE OF THE PIPE AND TIGHTEN SECURELY.
- SPIN THE JAM NUT (PART OF 992EMTN) ONTO THE SENSOR BODY (991TDS2 OR 991TDS22). APPLY A GENEROUS AMOUNT OF THERMAL COUPLANT (SUPPLIED WITH 992EMTN) TO THE FACE OF THE SENSOR AND SCREW IT INTO THE MOUNTING NUT. HAND TIGHT ENGAGEMENT IS SUFFICIENT. SECURE THE SENSOR BY TIGHTENING THE JAM NUT AGAINST THE MOUNTING NUT.
- SELECT A MOUNTING LOCATION FOR THE JUNCTION BOX USE INTEGRAL MOUNTING HOLES OR SECURE AT END OF RIGID CONDUIT. IF CONDUIT IS USED, REMOVE THE WATERTIGHT GLAND SUPPLIED WITH THE JUNCTION BOX. INSTALL THE 992ECC CABLE, MAKING WIRING CONNECTIONS 1-5 AS SHOWN.
- AFTER TEMPERATURE SENSOR HAS BEEN POSITIONED PROPERLY, PROTECTIVELY ENCAPSULATE IT AS FOLLOWS: PACK "DENSO" MASTIC AROUND TEMPERATURE SENSOR. SURFACE OF PIPE AND MOUNTING STRAP SHOULD BE CLEAN AND RUBBED WITH "DENSO" PASTE BEFORE WRAPPING. WRAP "DENSO" TAPE AROUND PIPE, STRAP AND TEMPERATURE SENSOR. SMOOTH THE TAPE SURFACE AFTER WRAPPING.
- MAKE CABLE CONNECTIONS TO THE 994 OR 1010 SERIES FLOWMETER IN ACCORDANCE WITH THE APPROPRIATE FLOWMETER INSTALLATION DRAWING.
- STANDARD TEMPERATURE SENSOR CABLE IS PART NUMBER 992ECC-(LENGTH) FOR PLENUM RATED CABLE ASSEMBLIES, USE CABLE PART NUMBER 992ECCD-(LENGTH)
- IF NECESSARY, TO ISOLATE RTD BODY FROM FLOW METER GROUND, DISCONNECT TERMINAL #5 AND TAPE BACK TO PREVENT ELECTRICAL CONTACT. THIS GROUND ISOLATION DOES NOT AFFECT SAFETY.
- SEE DRAWING 991TDS2-8 FOR OUTLINE DIMENSIONS.

**NOTES:**

- TO AID INSTALLATION, THE TEMP. SENSOR CABLE MAY BE DISCONNECTED FROM THE CABLE JUNCTION. THE CAP RING AND SEALING GLAND REMAIN ON CABLE.
- EACH TEMP SENSOR WRAP KIT CONSISTS OF:
  - 1-ROLL OF 2" WIDE "DENSO" TAPE
  - 1-1# BLOCK OF "DENSO" MASTIC
  - 1- 1/2# CONTAINER OF "DENSO" PASTE (P/N 991-82).

**BAND LENGTH TABLE**

PIPE DIA.	LENGTH TO CUT ON MARK	PIPE DIA.	LENGTH TO CUT ON MARK
6"	14-3/16"	16"	45-7/8"
7"	16-3/4"	17"	48-7/16"
8"	20-1/2"	18"	52-1/8"
9"	23-1/8"	19"	54-3/4"
10"	26-7/8"	20"	58-1/2"
11"	29-3/8"	22"	64-7/8"
12"	33-5/16"	24"	71-1/8"
13"	33-3/4"	26"	76-1/4"
14"	39-1/2"	28"	85-5/8"
15"	42-1/16"	30"	88-7/8"

**SIEMENS**  
 Siemens Energy & Automation, Inc.  
 Process Instrumentation Business Unit  
 CoC Ultrasonic Flow - Hauptpaugle, Long Island, NY 11788

**INSTALLATION DRAWING**  
 991TD TEMPERATURE SENSOR  
 SUBMERSIBLE, "FM" APPROVED

DATE: \_\_\_\_\_  
 H/J: \_\_\_\_\_  
 DR: \_\_\_\_\_  
 CHK: \_\_\_\_\_  
 ENG: \_\_\_\_\_  
 PRD: \_\_\_\_\_  
 APP: \_\_\_\_\_  
 CERTIFIED: \_\_\_\_\_

DATE: 11/14/96

UNLESS OTHERWISE SPECIFIED:  
 DIMENSIONS ARE IN INCHES (MM)  
 TOLERANCES ON-

INCHES (MM)  
 ± .1 (± 2)

MATERIAL: \_\_\_\_\_  
 FINISH: \_\_\_\_\_

SIZE: \_\_\_\_\_  
 SAP MATERIAL NO.: \_\_\_\_\_  
 ITEM NO.: \_\_\_\_\_  
 DOCUMENT NO.: 991TDS2-7  
 SCALE: NONE WT.

REV: \_\_\_\_\_  
 AS  
 DS 03

SHEET 1 OF 1



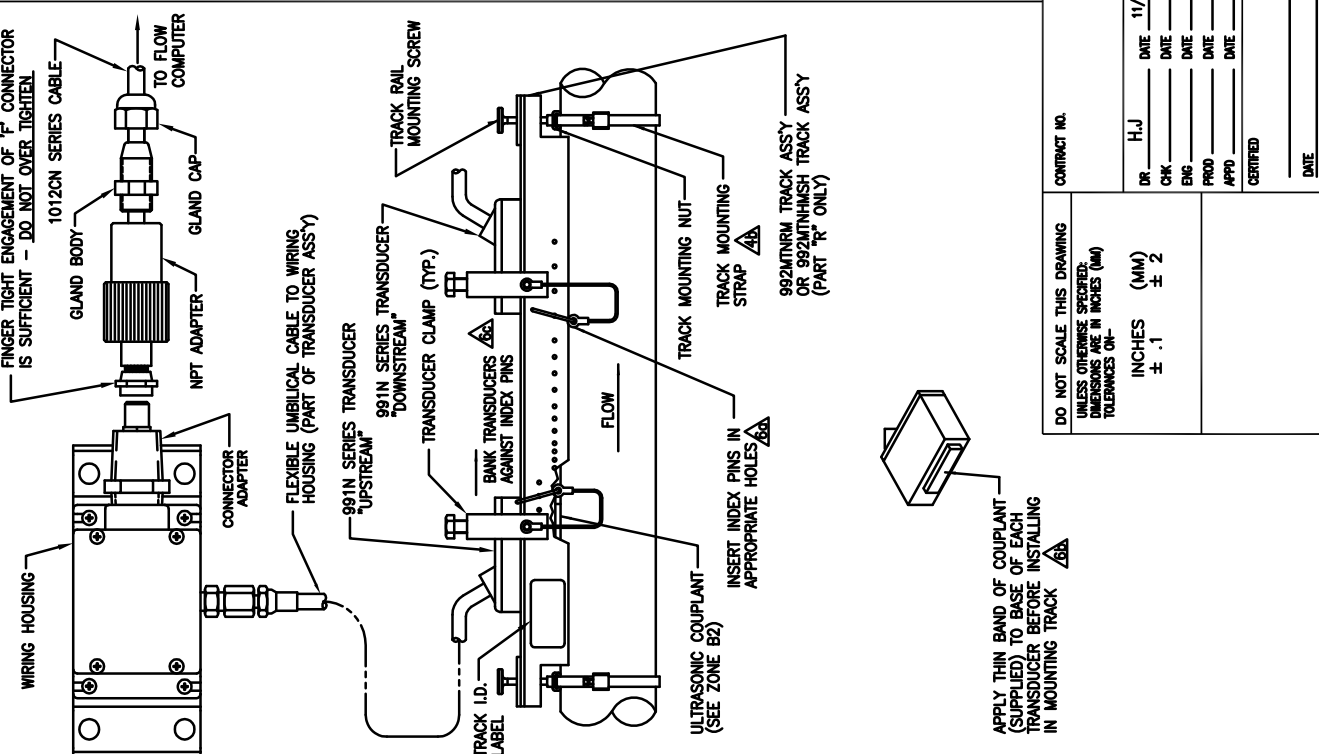
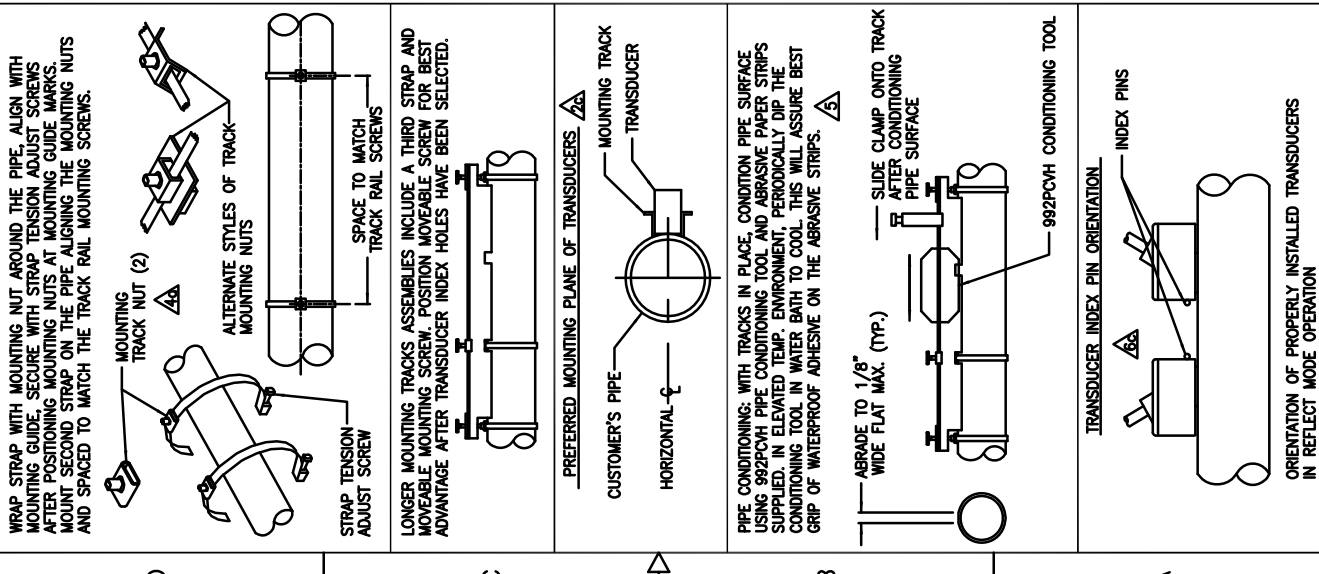

- INSTALLATION PROCEDURE - SEE DRAWING REFERENCES A**
1. USING THE INSTALLATION MENU PROCEDURES PRESENTED IN THE FIELD MANUAL, CONFIRM THAT YOU HAVE THE APPROPRIATE TRANSDUCERS AND TRACK FOR REFLECT MODE OPERATION ON THE CHOSEN PIPE.
  2. SELECT MOUNTING LOCATION:
    - a) CHOOSE LOCATION WHICH REMAINS FULL AT ZERO FLOW.
    - b) WHERE POSSIBLE LOCATE TRACK ASSY TEN (10) PIPE DIAMETERS OR MORE FROM BEND TO ENSURE FULLY DEVELOPED AND STABLE FLOW PROFILE.
    - c) ON HORIZONTAL PIPE, SELECT HORIZONTAL PLANE, IF POSSIBLE, TO AVOID SEDIMENT BLOCKAGE OF TRANSDUCER SIGNAL.
  3. PREPARE PIPE FOR TRACK MOUNT:
    - a) REMOVE GRIT, CORROSION, COATING OR HEAVY PAINT
    - b) CLEAN AND DEGREASE SURFACE.
    - c) DO NOT MOUNT OVER FROST.
  4. MOUNT TRACK ON PIPE:
    - a) SLIP ONE OF THE MOUNTING NUTS PROVIDED ONTO EACH OF THE MOUNTING STRAPS. WRAP THE STRAPS AROUND THE PIPE AT THE SELECTED LOCATION AND ENGAGE THE ADJUSTING SCREWS. POSITION THE MOUNTING NUTS IN LINE WITH THE FLOW AXIS AND SPACED TO MATE WITH THE STRAPS AT EITHER END OF THE TRACK ASSEMBLY. SECURE THE STRAPS (AND NUTS) BY TIGHTENING THE MOUNTING STRAP ADJUSTING SCREWS.
    - b) SECURE THE TRACK RAIL ASSEMBLY TO THE PIPE USING THE TRACK RAIL MOUNTING SCREWS.
  5. CONDITION PIPE SURFACE:
 

LOCALLY SMOOTH THE PIPE SURFACE TO ACCEPT THE TRANSDUCERS. USE THE 992PCVH CONDITIONING TOOL AND ABRASIVE PAPER (ADHESIVE BACKED) PROVIDED. FINISHED SURFACE SHOULD BE APPROXIMATELY 1/8" WIDE FLAT AT CENTER OF MOUNTING TRACK.
  6. LOCATE TRANSDUCERS:
    - a) CONSULTING THE FIELD MANUAL, USE THE INSTALLATION MENU TO DETERMINE THE APPROPRIATE INDEX HOLES FOR YOUR APPLICATION AND INSERT PINS.
    - b) APPLY A THIN BAND OF THE ULTRASONIC COUPLANT PROVIDED TO THE BASE OF EACH TRANSDUCER.
    - c) INSERT TRANSDUCERS INTO TRACK AS SHOWN, BANKING AGAINST INDEX PINS. SECURE TRANSDUCERS WITH CLAMPS.
  7. MAKE TRANSDUCER CABLE CONNECTIONS IN ACCORDANCE WITH THE APPROPRIATE FLOW COMPUTER INSTALLATION DRAWING AND 990 FIELD MANUAL.
  8. SEE DRAWING 992TRMH-8 AND 990TRMH-8 FOR TRACK AND TRANSDUCER OUTLINE DIMENSIONS.
  9. SEE DRAWING 992-60-7 FOR ASSEMBLY OF CUT-TO-FIT ADJUSTABLE MOUNTING STRAPS.

WRAP STRAP WITH MOUNTING NUT AROUND THE PIPE, ALIGN WITH MOUNTING GUIDE. SECURE WITH STRAP TENSION ADJUST SCREWS AFTER POSITIONING MOUNTING NUTS AT MOUNTING GUIDE MARKS. MOUNT SECOND STRAP ON THE PIPE ALIGNING THE MOUNTING NUTS AND SPACED TO MATCH THE TRACK RAIL MOUNTING SCREWS.

LONGER MOUNTING TRACKS ASSEMBLIES INCLUDE A THIRD STRAP AND MOVEABLE MOUNTING SCREW. POSITION MOVEABLE SCREW FOR BEST ADVANTAGE AFTER TRANSDUCER INDEX HOLES HAVE BEEN SELECTED.

PIPE CONDITIONING: WITH TRACKS IN PLACE, CONDITION PIPE SURFACE USING 992PCVH PIPE CONDITIONING TOOL AND ABRASIVE PAPER STRIPS SUPPLIED. IN ELEVATED TEMP. ENVIRONMENT, PERIODICALLY DIP THE CONDITIONING TOOL IN WATER BATH TO COOL. THIS WILL ASSURE BEST GRIP OF WATERPROOF ADHESIVE ON THE ABRASIVE STRIPS.

ABRADE TO 1/8" WIDE FLAT MAX. (TYP.)

SLIDE CLAMP ONTO TRACK AFTER CONDITIONING PIPE SURFACE

TRANSDUCER INDEX PIN ORIENTATION

ORIENTATION OF PROPERLY INSTALLED TRANSDUCERS IN REFLECT MODE OPERATION

4

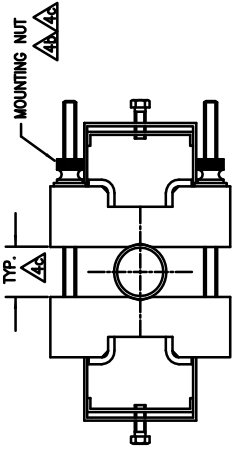

SELECT AND PREPARE THE TRANSDUCER MOUNTING LOCATION, SECURE TRACKS TO PIPE WITH MOUNTING NUTS. HORIZONTAL  $\phi$  SHOWN

3

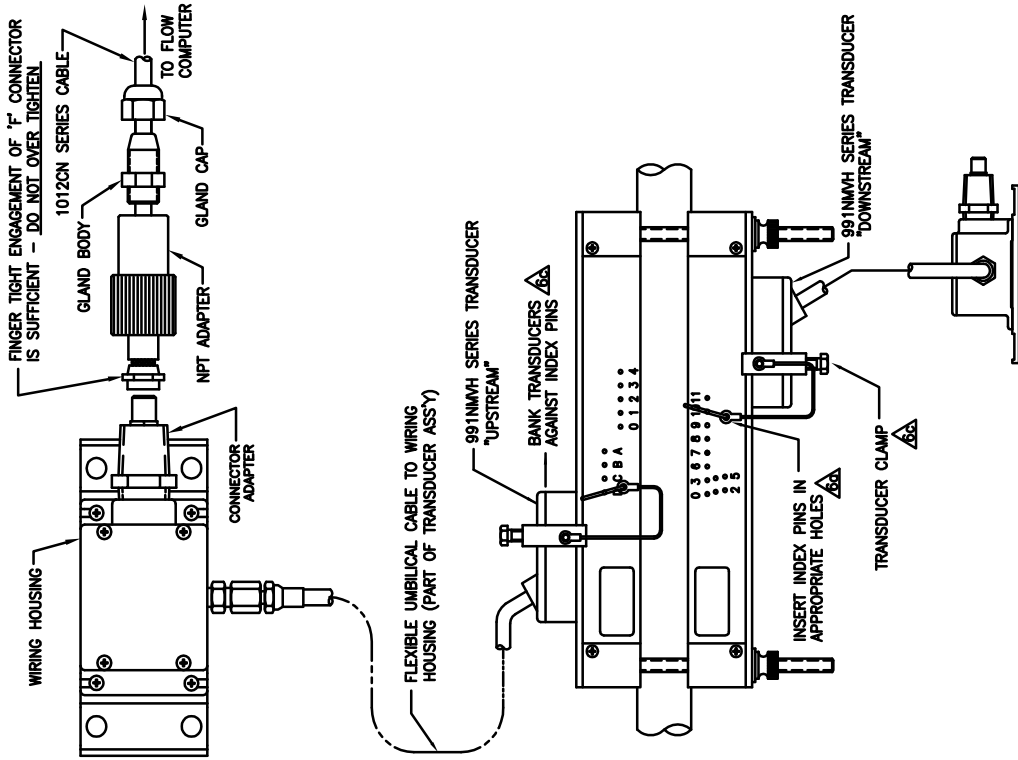

2

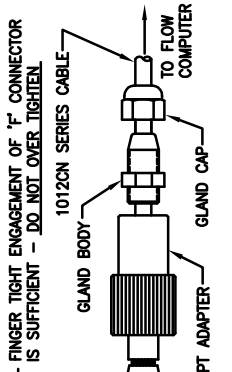

1

- INSTALLATION PROCEDURE - SEE DRAWING REFERENCES  $\Delta$**
- USING THE INSTALLATION MENU PROCEDURES PRESENTED IN THE FIELD MANUAL, CONFIRM THAT YOU HAVE THE APPROPRIATE TRANSDUCERS AND TRACK FOR REFLECT MODE OPERATION ON THE CHOSEN PIPE.
  - SELECT MOUNTING LOCATION:
    - CHOOSE LOCATION WHICH REMAINS FULL AT ZERO FLOW.
    - WHERE POSSIBLE LOCATE TRACK ASSY TEN (10) PIPE DIAMETERS OR MORE FROM BEND TO ENSURE FULLY DEVELOPED AND STABLE FLOW PROFILE.
    - ON HORIZONTAL PIPE, SELECT HORIZONTAL PLANE. IF POSSIBLE, TO AVOID SEDIMENT BLOCKAGE OF TRANSDUCER SIGNAL.
  - PREPARE PIPE FOR TRACK MOUNT:
    - REMOVE GRIT, CORROSION, COATING OR HEAVY PAINT
    - CLEAN AND DEGREASE SURFACE
    - DO NOT MOUNT OVER FROST.
  - MOUNT TRACK ON PIPE:
    - PLACE TRACK RAIL ASSY (ASSY WITH 1/4-20 STUDS) AGAINST PIPE. WHILE HOLDING TRACK, SLIDE THE SECOND TRACK ONTO THE STUDS AND HOLD TOGETHER IN PLACE (MAKE SURE 'Y's COME TOGETHER AS SHOWN).
    - INSTALL MOUNTING NUTS, SNUG BUT NOT OVERLY TIGHT. ROTATE ASSY AROUND THE PIPE FOR PROPER POSITIONING. ONCE THAT HAS BEEN ACHIEVED, SECURE THE TRACK RAIL ASSY TO THE PIPE WITH THE MOUNTING NUTS.
    - IMPORTANT: KEEP EQUAL SPACING BETWEEN THE TWO TRACK RAIL ASSEMBLIES WHILE TIGHTENING THE MOUNTING NUTS. (ZONE D4)
  - CONDITION PIPE SURFACE:
    - LOCALLY SMOOTH THE PIPE SURFACE TO ACCEPT THE TRANSDUCERS. USE THE 992PCVH CONDITIONING TOOL AND ABRASIVE PAPER (ADHESIVE BACKED) PROVIDED. FINISHED SURFACE SHOULD BE APPROXIMATELY 1/8" WIDE FLAT AT CENTER OF MOUNTING TRACK.
  - LOCATE TRANSDUCERS:
    - CONSULTING THE FIELD MANUAL, USE THE APPROPRIATE INSTALLATION MENU TO DETERMINE THE APPROPRIATE INDEX HOLES FOR YOUR APPLICATION AND INSERT PINS.
    - APPLY A THIN BAND OF THE ULTRASONIC COUPLANT PROVIDED TO THE BASE OF EACH TRANSDUCER.
    - INSERT TRANSDUCERS INTO TRACK AS SHOWN, BANKING AGAINST INDEX PINS. SECURE TRANSDUCERS WITH CLAMPS.
  - MAKE TRANSDUCER CABLE CONNECTIONS IN ACCORDANCE WITH THE APPROPRIATE FLOW COMPUTER INSTALLATION DRAWING AND 990 FIELD MANUAL.
  - SEE DRAWING 990TDMVH-8A AND 990THMVH-8A FOR TRACK AND TRANSDUCER OUTLINE DIMENSIONS.

4

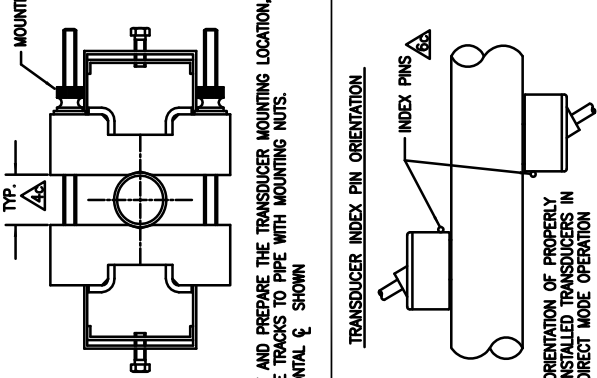

PIPE CONDITIONING: WITH TRACKS IN PLACE, CONDITION PIPE SURFACE USING 992PCVH PIPE CONDITIONING TOOL AND ABRASIVE PAPER STRIPS SUPPLIED. IN ELEVATED TEMP. ENVIRONMENT, PERIODICALLY DIP THE CONDITIONING TOOL IN WATER BATH TO COOL. THIS WILL ASSURE BEST GRIP OF WATERPROOF ADHESIVE ON THE ABRASIVE STRIPS.

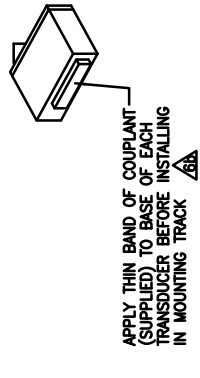
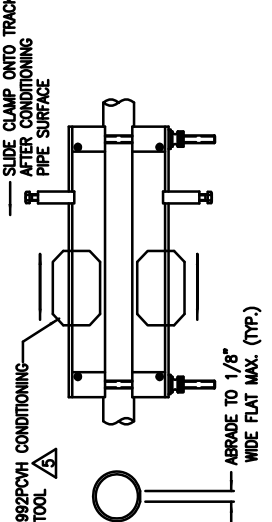

<p><b>SIEMENS</b> Siemens Energy &amp; Automation, Inc. Process Instrumentation Business Unit CoC Ultrasonic Flow - Hauppauge, Long Island, NY 11788</p>		<p><b>INSTALLATION DRAWING</b> 990 SERIES TRANSDUCER DIRECT MODE, VERY HIGH TEMP.</p>	
<p>CONTRACT NO. H.J</p>	<p>DATE 11/03/04</p>	<p>SIZE C 21614</p>	<p>REV. B</p>
<p>DR CHK ENG PRD APPD CERTIFIED DATE</p>	<p>DATE DATE DATE DATE DATE DATE</p>	<p>CODE IDENT NO. 990TDMVH-7A</p>	<p>SHEET 1 OF 1</p>
<p>DO NOT SCALE THIS DRAWING UNLESS OTHERWISE SPECIFIED: DIMENSIONS ARE IN INCHES (MM) TOLERANCES ON-</p> <p>INCHES <math>\pm .1</math> (MM) <math>\pm 2</math></p>		<p>SCALE: NONE</p>	<p>WT.</p>

4

3

2

1

CN#5216



**INSTALLATION PROCEDURE** - SEE DRAWING REFERENCES

1. USING THE INSTALLATION MENU PROCEDURES PRESENTED IN THE FIELD MANUAL, CONFIRM THAT YOU HAVE THE APPROPRIATE TRANSDUCERS AND TRACK FOR REFLECT MODE OPERATION ON THE CHOSEN PIPE.
2. SELECT MOUNTING LOCATION;
  - a) CHOOSE LOCATION WHICH REMAINS FULL AT ZERO FLOW.
  - b) WHERE POSSIBLE LOCATE TRACK ASSY TEN (10) PIPE DIAMETERS OR MORE UPSTREAM OF TRACK TO ENSURE FULLY DEVELOPED AND STABLE FLOW.
  - c) ON HORIZONTAL PIPE, SELECT HORIZONTAL PLANE, IF POSSIBLE, TO AVOID SEDIMENT BLOCKAGE OF TRANSDUCER SIGNAL.
3. PREPARE PIPE FOR TRACK MOUNT;
  - a) REMOVE GRIT, CORROSION, COATING OR HEAVY PAINT
  - b) CLEAN AND DEBRASS SURFACE.
  - c) DO NOT MOUNT OVER FROST.
4. MOUNT TRACK ON PIPE;
  - a) PLACE TRACK RAIL ASSY (ASSY WITH 1/4"-20 STUDS) AGAINST PIPE WHILE HOLDING TRACK SLIDE THE POSITIONING BLOCK ONTO THE STUDS AND HOLD TOGETHER IN PLACE.
  - b) INSTALL MOUNTING NUTS, SNUG BUT NOT OVERLY TIGHT. ROTATE ASSY AROUND THE PIPE FOR PROPER POSITIONING, ONCE THAT HAS BEEN ACHIEVED, SECURE THE TRACK RAIL ASSY TO THE PIPE WITH THE MOUNTING NUTS. (ZONE D4)
  - c) IMPORTANT: KEEP EQUAL SPACING BETWEEN THE TWO TRACK RAIL ASSEMBLIES WHILE TIGHTENING THE MOUNTING NUTS. (ZONE D4)
5. CONDITION PIPE SURFACE;
  - a) LOCALLY SMOOTH THE PIPE SURFACE TO ACCEPT THE TRANSDUCERS. USE THE 992PCVH CONDITIONING TOOL AND ABRASIVE PAPER (ADHESIVE BACKED) PROVIDED. FINISHED SURFACE SHOULD BE APPROXIMATELY 1/8" WIDE FLAT AT CENTER OF MOUNTING TRACK.
  - b) CONSULTING THE FIELD MANUAL, USE THE INSTALLATION MENU TO DETERMINE THE APPROPRIATE INDEX HOLES FOR YOUR APPLICATION AND INSERT PINS.
  - c) APPLY A THIN BAND OF THE ULTRASONIC COUPLANT PROVIDED TO THE BASE OF EACH TRANSDUCER.
  - d) INSERT TRANSDUCERS INTO TRACK AS SHOWN, BANKING AGAINST INDEX PINS. SECURE TRANSDUCERS WITH CLAMPS.
6. MAKE TRANSDUCER CABLE CONNECTIONS IN ACCORDANCE WITH THE APPROPRIATE FLOW COMPUTER INSTALLATION DRAWING AND 990 FIELD MANUAL.
7. SEE DRAWING 990TRMVH-8A AND 990TRMVH-8A FOR TRACK AND TRANSDUCER OUTLINE DIMENSIONS.

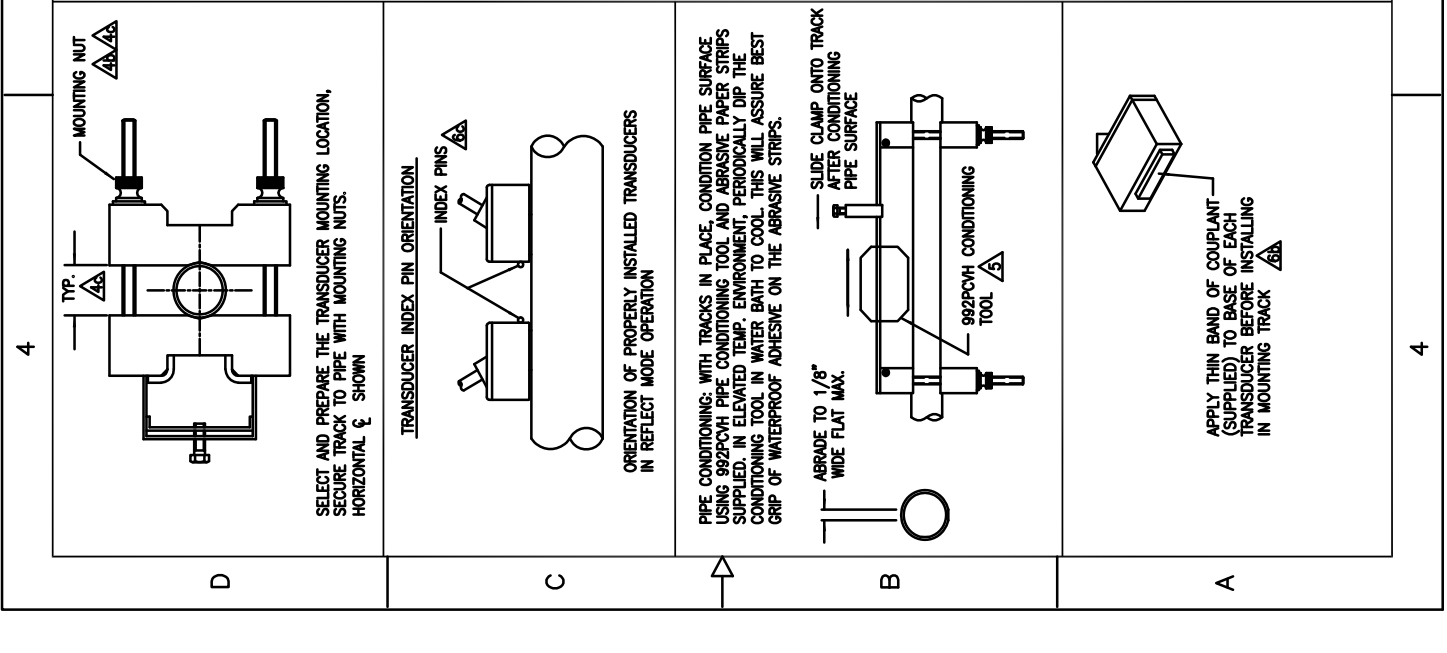
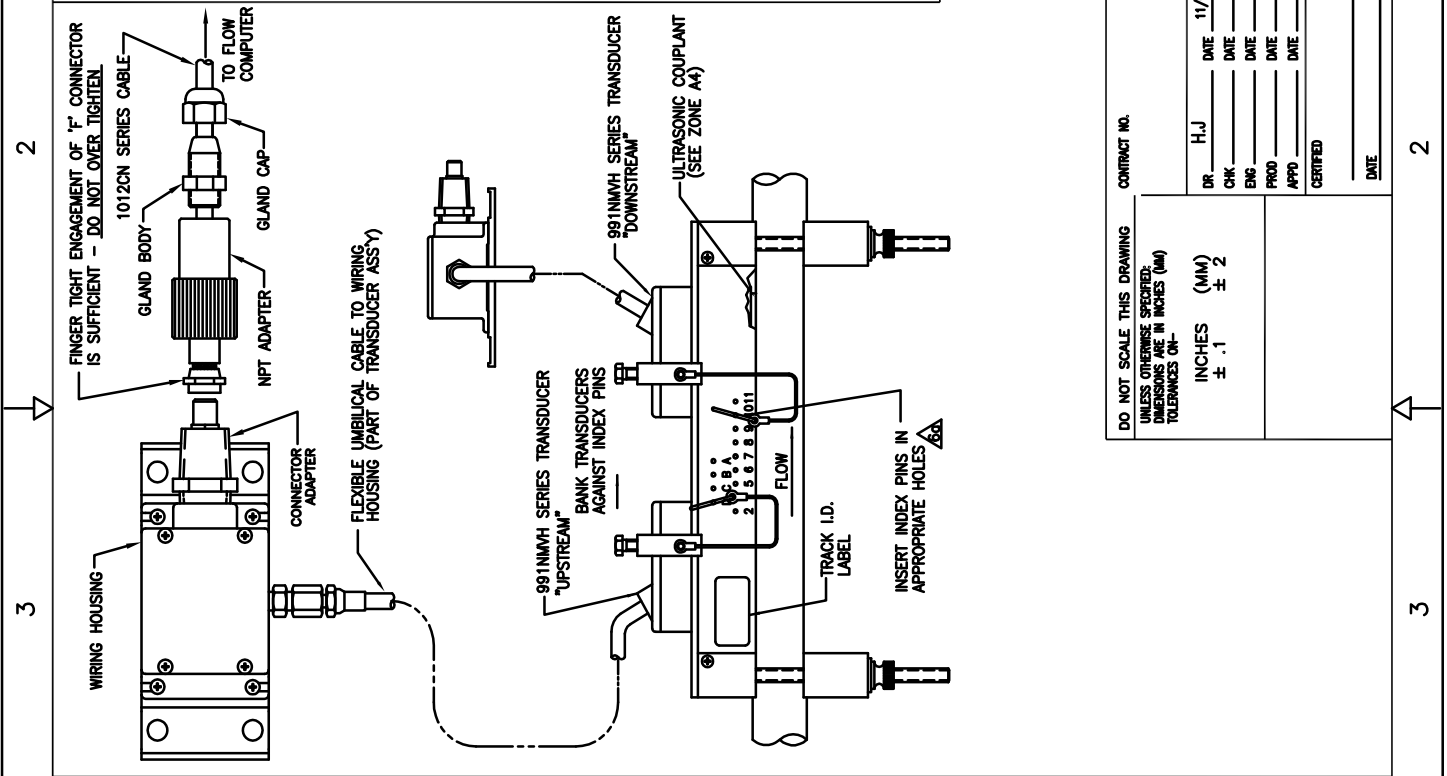

<b>SIEMENS</b> Siemens Energy & Automation, Inc. Process Instrumentation Business Unit CoC Ultrasonic Flow - Hauppauge, Long Island, NY 11788		<b>CONTRACT NO.</b>	
<b>INSTALLATION DRAWING</b> 990 SERIES TRANSDUCER REFLECT MODE, VERY HIGH TEMP.		DR - HJJ	DATE 11/03/04
SIZE <b>C</b>	CODE IDENT NO. <b>21614</b>	CHK _____	DATE _____
SCALE: NONE	WT.	ENG _____	DATE _____
REV. <b>C</b>	990TRMVH-7A	PRD _____	DATE _____
SHEET 1 OF 1	CN#5216	APPD _____	DATE _____
		CERTIFIED _____	DATE _____

1

2

3

4

**INSTALLATION PROCEDURE - SEE DRAWING REFERENCE**

- INSTALLATION OF THE DEDICATED NEMA 4 TEMPERATURE SENSOR FOR PIPES 1 1/4" 48" DIAMETER REQUIRES THE FOLLOWING: THE SENSOR 991T(S), A MOUNTING ASSY 992EMTN-2, A JAM NUT (P/O 992EMTN) AND A CABLE 992ECC (LENGTH) IN TWO PARTS, JUNCTION 992ECCJ AND CABLE 992ECC-(LENGTH).
- TEMPERATURE SENSORS ARE SUPPLIED IN PAIRS (P/N 991T) FOR THERMAL ENERGY FLOWMETER APPLICATIONS OR SINGLY (P/N 991TS) FOR TEMPERATURE COMPENSATED MASS FLOWMETER APPLICATIONS AND INTERFACE DETECTION.
- SELECT THE PIPE LOCATION WHERE TEMPERATURE IS TO BE MONITORED IN ACCORDANCE WITH RECOMMENDATIONS IN THE FIELD MANUAL.
- CLEAN A SMALL AREA OF PIPE SURFACE (APPROXIMATELY 1" DIAMETER); REMOVE PAINT, SCALE, FOREIGN MATTER THAT CAN AFFECT GOOD THERMAL CONTACT.
- CENTER THE MOUNTING NUT (PART OF 992EMTN) OVER THE CLEAN SPOT AND STRAP IN PLACE ALLOW THE STRAP TO REACH APPROXIMATELY THE TEMPERATURE OF THE PIPE AND TIGHTEN SECURELY.
- SPIN THE JAM NUT (PART OF 992EMTN) ONTO THE 991T SENSOR BODY. APPLY A GENEROUS AMOUNT OF THERMAL CONDUCTIVE PASTE (SUPPLIED WITH 992EMTN) TO THE FACE OF THE SENSOR AND SCREW IT INTO THE MOUNTING NUT. HAND TIGHT ENGAGEMENT IS SUFFICIENT. SECURE THE SENSOR BY TIGHTENING THE JAM NUT AGAINST THE MOUNTING NUT.
- SELECT A MOUNTING LOCATION FOR THE 992ECCJ JUNCTION BOX. USE INTEGRAL MOUNTING FLANGES OR SECURE AT THE END OF RIGID CONDUIT. IF CONDUIT IS USED, REMOVE THE WATERTIGHT GLAND SUPPLIED WITH THE 992ECC CABLE. INSTALL THE 992ECC CABLE, MAKING WIRING CONNECTIONS 1-5 AS SHOWN.
- SLIP THE SPONGE INSULATOR (SUPPLIED WITH 991T) OVER THE CONNECTOR AND CABLE PART OF JUNCTION 994ECCJ. MATE THE JUNCTION CONNECTOR TO THE 991T. PUSH THE INSULATOR ONTO THE SENSOR BODY.
- MAKE CABLE CONNECTIONS TO THE 994 OR 1010 SERIES METER IN ACCORDANCE WITH THE APPROPRIATE INSTALLATION DRAWING.
- SEE DRAWING 991TN-8 FOR OUTLINE DIMENSIONS.

**PERMANENT INSTALLATION / SERVICE NOTE**

INSULATION IN THE IMMEDIATE VICINITY OF THE 991T SENSOR SHOULD BE REMOVABLE TO ALLOW FOR TOOL ACCESS REQUIRED FOR PERIODIC REFRESHMENT OF CC117 THERMAL COMPOUND.



**INSTALLATION DRAWING  
TEMPERATURE SENSOR  
DEDICATED, NEMA 4**

SIZE	CODE IDENT NO.	REV.
C	21614	G
SCALE: NONE	WT.	SHEET 1 OF 1
	991TN - 7	

CABLE GLAND SUPPLIED WITH JUNCTION BOX FOR 992ECC SERIES CABLE. JUNCTION BOX ENTRY WILL ACCOMMODATE 1/2" NPT CONDUIT FITTING WITH LOCKNUT ON THE INSIDE.

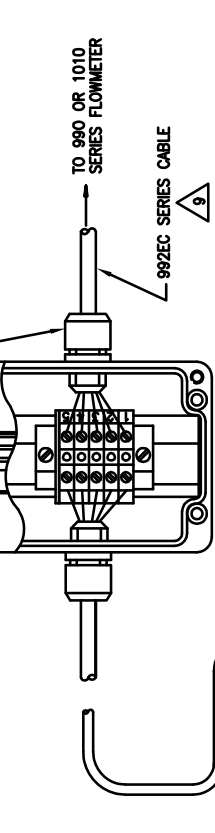

TO 990 OR 1010 SERIES FLOWMETER  
992ECC SERIES CABLE

991T SENSOR S/N PLATE: WHEN USED IN PAIRS (THERMAL ENERGY MEASUREMENT) SERIAL NUMBERS MUST MATCH (eg. 1234A, 1234B)

TEMPERATURE SENSOR (991T)  
APPLY GENEROUS AMOUNT OF CC117 TO FACE OF THE SENSOR BEFORE INSTALLING IN MOUNT

JAM NUT (P/O 992EMTN) 6  
MOUNTING NUT (P/O 992EMTN) 5

SPONGE INSULATOR 6  
CUSTOMER'S PIPE  
MOUNTING STRAP

FOR WASH OR HEAVY CONDENSATE ENVIRONMENTS:  
SERVICE TEMPERATURE RANGE: -40°F TO +180°F

CC110 30cc CONTAINER PROVIDED  
IMMERSE CONNECTOR IN CONTAINER OF CC110. COMPLETELY FILLING AND COATING IT BEFORE CONNECTING TO 991T TEMP. SENSOR. ADDITIONAL COATING MAY BE REQUIRED AS PART OF A NORMAL MAINTENANCE SCHEDULE.

**STEP - 1**  
DETERMINE PROPER BAND LENGTH ONE OF TWO WAYS:  
A) IF DIAMETER IS KNOWN, REFER TO BAND LENGTH TABLE OR CALCULATE BAND LENGTH = 3.14 x DIA. - 3.5".  
B) IF DIAMETER IS NOT KNOWN, MEASURE CIRCUMFERENCE WITH STRING, TAPE, etc., AND SUBTRACT 3.5" (TO ALLOW LENGTH OF FASTENER) TO DETERMINE PROPER BAND LENGTH.

**STEP - 2**  
MEASURE BAND TO PROPER LENGTH AND CUT THROUGH CENTER OF NEAREST ROUND HOLE WITH SHEARS, SNIPS, HACKSAW etc.

**STEP - 3**  
EITHER MATE FASTENER HALVES AND THEN LINK TO STRAP ALREADY IN PLACE AROUND PIPE, OR LINK FASTENER HALVES INDEPENDENTLY TO STRAP ENDS (HOLD IN PLACE WITH TAPE IF (IF NECESSARY) AND ENGAGE FASTENER AFTER WRAPPING STRAP AROUND PIPE.

DIAGONALLY INSERT FASTENER END INTO RECTANGULAR SLOTS TO LINK WITH STRAP (INSERT AT LOCATION BEST SUITED FOR TIGHT FIT).

**STEP - 4**  
MATE 1" ON FASTENERS WITH RECTANGULAR CUT-OUT ON MOUNTING NUT ASSEMBLY.  
SIZE 2 MOUNTING ASSY'S INCLUDE FIXED LENGTH STRAPS TO MATE WITH FASTENERS ATTACHED TO MOUNTING NUT.  
SIZES 3 & 4 MOUNTING ASSY'S INCLUDE A CUT-TO-FIT MOUNTING STRAP. (SEE STEP 3).

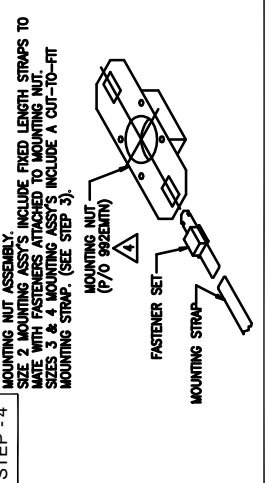

**BAND LENGTH TABLE**

PIPE DIA.	LENGTH TO CUT ON MARK	PIPE DIA.	LENGTH TO CUT ON MARK	PIPE DIA.	LENGTH TO CUT ON MARK
6"	14-3/16"	16"	45-7/8"	32"	95-3/8"
7"	16-3/4"	17"	48-7/16"	34"	101-5/8"
8"	20-1/2"	18"	52-1/8"	36"	107-7/8"
9"	23-1/8"	19"	54-3/4"	38"	114-1/4"
10"	26-7/8"	20"	58-1/2"	40"	120-9/16"
11"	29-3/8"	22"	64-7/8"	42"	127"
12"	33-5/16"	24"	71-1/8"	44"	133-5/16"
13"	33-3/4"	26"	76-1/4"	46"	139-5/8"
14"	39-1/2"	28"	85-5/8"	48"	145-15/16"
15"	42-1/16"	30"	88-7/8"		

DO NOT SCALE THIS DRAWING UNLESS OTHERWISE SPECIFIED. DIMENSIONS ARE IN INCHES (MM) TOLERANCES ON-

INCHES ± .1 (MM) ± .2

CONTRACT NO. \_\_\_\_\_

DATE 10/26/96

DR HJJ \_\_\_\_\_ DATE \_\_\_\_\_

CHK \_\_\_\_\_ DATE \_\_\_\_\_

ENG \_\_\_\_\_ DATE \_\_\_\_\_

PROD \_\_\_\_\_ DATE \_\_\_\_\_

APPD \_\_\_\_\_ DATE \_\_\_\_\_

CERTIFIED \_\_\_\_\_

DATE \_\_\_\_\_

1

2

3

4

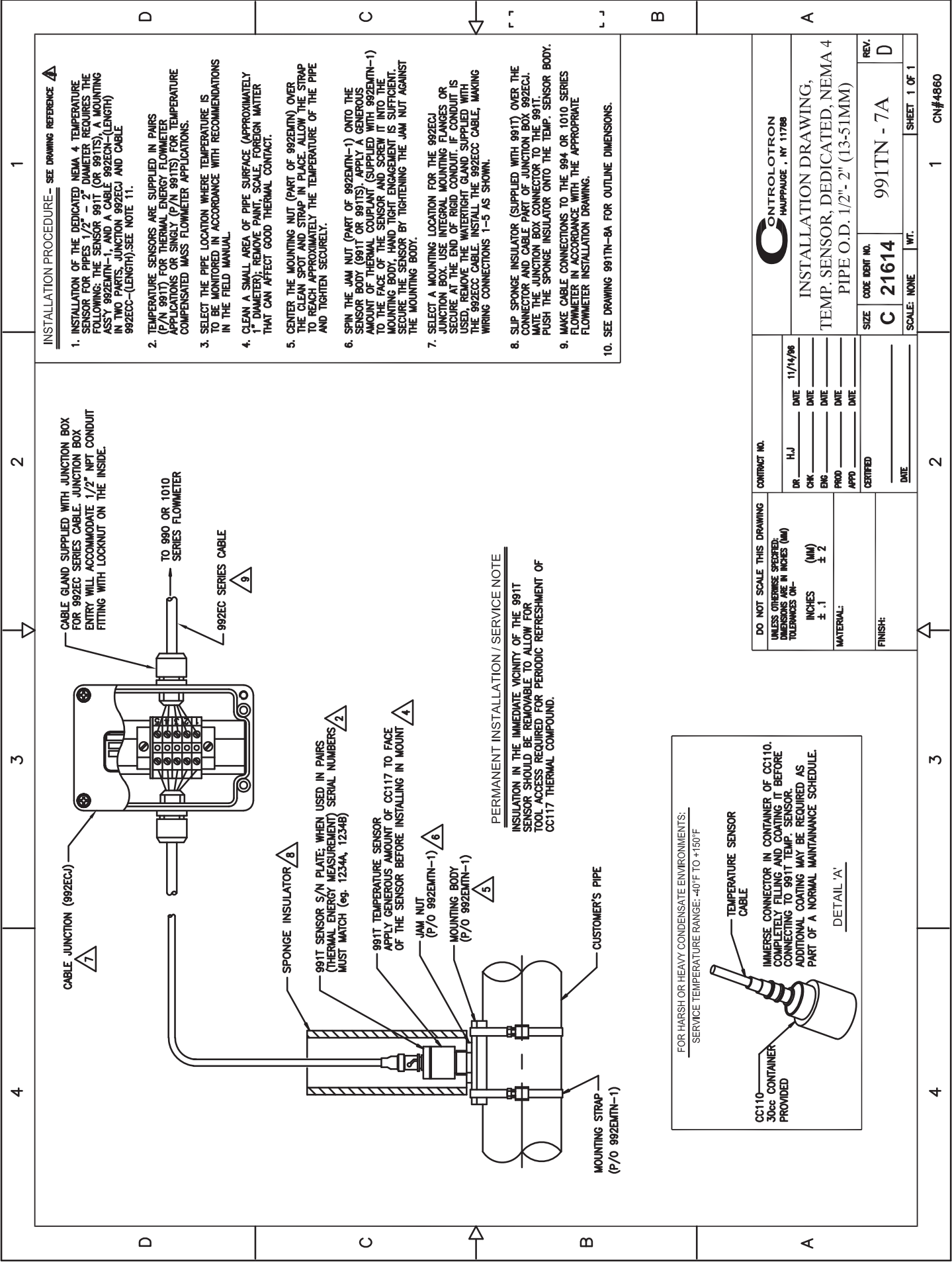

**INSTALLATION PROCEDURE - SEE DRAWING REFERENCE  $\Delta$**

1. INSTALLATION OF THE DEDICATED NEMA 4 TEMPERATURE SENSOR FOR PIPES 1/2" - 2" DIAMETER REQUIRES THE FOLLOWING: THE SENSOR 991T (OR 991TS), A MOUNTING ASSY 992EMTN-1, AND A CABLE 992ECN-(LENGTH) IN TWO PARTS, JUNCTION 992ECJ AND CABLE 992ECC-(LENGTH). SEE NOTE 11.
2. TEMPERATURE SENSORS ARE SUPPLIED IN PAIRS (P/N 991T) FOR THERMAL ENERGY FLOWMETER APPLICATIONS OR SINGLY (P/N 991TS) FOR TEMPERATURE COMPENSATED MASS FLOWMETER APPLICATIONS.
3. SELECT THE PIPE LOCATION WHERE TEMPERATURE IS TO BE MONITORED, IN ACCORDANCE WITH RECOMMENDATIONS IN THE FIELD MANUAL.
4. CLEAN A SMALL AREA OF PIPE SURFACE (APPROXIMATELY 1" DIAMETER); REMOVE PAINT, SCALE, FOREIGN MATTER THAT CAN AFFECT GOOD THERMAL CONTACT.
5. CENTER THE MOUNTING NUT (PART OF 992EMTN) OVER THE CLEAN SPOT AND STRAP IN PLACE. ALLOW THE STRAP TO REACH APPROXIMATELY THE TEMPERATURE OF THE PIPE AND TIGHTEN SECURELY.
6. SPIN THE JAM NUT (PART OF 992EMTN-1) ONTO THE SENSOR BODY (991T OR 991TS). APPLY A GENEROUS AMOUNT OF THERMAL COUPLANT (SUPPLIED WITH 992EMTN-1) TO THE FACE OF THE SENSOR AND SCREW IT INTO THE MOUNTING BODY. HAND TIGHT ENGAGEMENT IS SUFFICIENT. SECURE THE SENSOR BY TIGHTENING THE JAM NUT AGAINST THE MOUNTING BODY.
7. SELECT A MOUNTING LOCATION FOR THE 992ECJ JUNCTION BOX. USE INTEGRAL MOUNTING FLANGES OR SECURE AT THE END OF RIGID CONDUIT. IF CONDUIT IS USED, REMOVE THE WATERTIGHT GLAND SUPPLIED WITH THE 992ECC CABLE. INSTALL THE 992ECC CABLE, MAKING WIRING CONNECTIONS 1-5 AS SHOWN.
8. SLIP SPONGE INSULATOR (SUPPLIED WITH 991T) OVER THE CONNECTOR AND CABLE PART OF JUNCTION BOX 992ECJ. MAKE THE JUNCTION BOX CONNECTOR TO THE 991T. PUSH THE SPONGE INSULATOR ONTO THE TEMP. SENSOR BODY.
9. MAKE CABLE CONNECTIONS TO THE 994 OR 1010 SERIES FLOWMETER IN ACCORDANCE WITH THE APPROPRIATE FLOWMETER INSTALLATION DRAWING.
10. SEE DRAWING 991TN-8A FOR OUTLINE DIMENSIONS.

**PERMANENT INSTALLATION / SERVICE NOTE**

INSULATION IN THE IMMEDIATE VICINITY OF THE 991T SENSOR SHOULD BE REMOVABLE TO ALLOW FOR TOOL ACCESS REQUIRED FOR PERIODIC REFRESHMENT OF CC117 THERMAL COMPOUND.

FOR HARSH OR HEAVY CONDENSATE ENVIRONMENTS:  
SERVICE TEMPERATURE RANGE: -40°F TO +150°F

IMMERSE CONNECTOR IN CONTAINER OF CC110. COMPLETELY FILLING AND COATING IT BEFORE CONNECTING TO 991T TEMP. SENSOR. ADDITIONAL COATING MAY BE REQUIRED AS PART OF A NORMAL MAINTENANCE SCHEDULE.

DETAIL 'A'

		HAUPPAUGE, NY 11788	
INSTALLATION DRAWING, TEMP. SENSOR, DEDICATED, NEMA 4 PIPE O.D. 1/2" - 2" (13-51MM)			
SIZE <b>C 21614</b>	CODE IDENT NO. 991TN - 7A	REV. <b>D</b>	
SCALE: NONE	WT.	SHEET 1 OF 1	CN#4860

CONTRACT NO. DR HJJ CHK DME ENG DME PRD DME APPD DME CERTIFIED DATE	11/14/06 DME DME DME DME
--	--------------------------------------

DO NOT SCALE THIS DRAWING UNLESS OTHERWISE SPECIFIED. DIMENSIONS ARE IN INCHES (mm) TOLERANCES UNLESS OTHERWISE SPECIFIED: INCHES $\pm .1$ (MM) $\pm .2$ MATERIAL: FINISH:	2
---	---

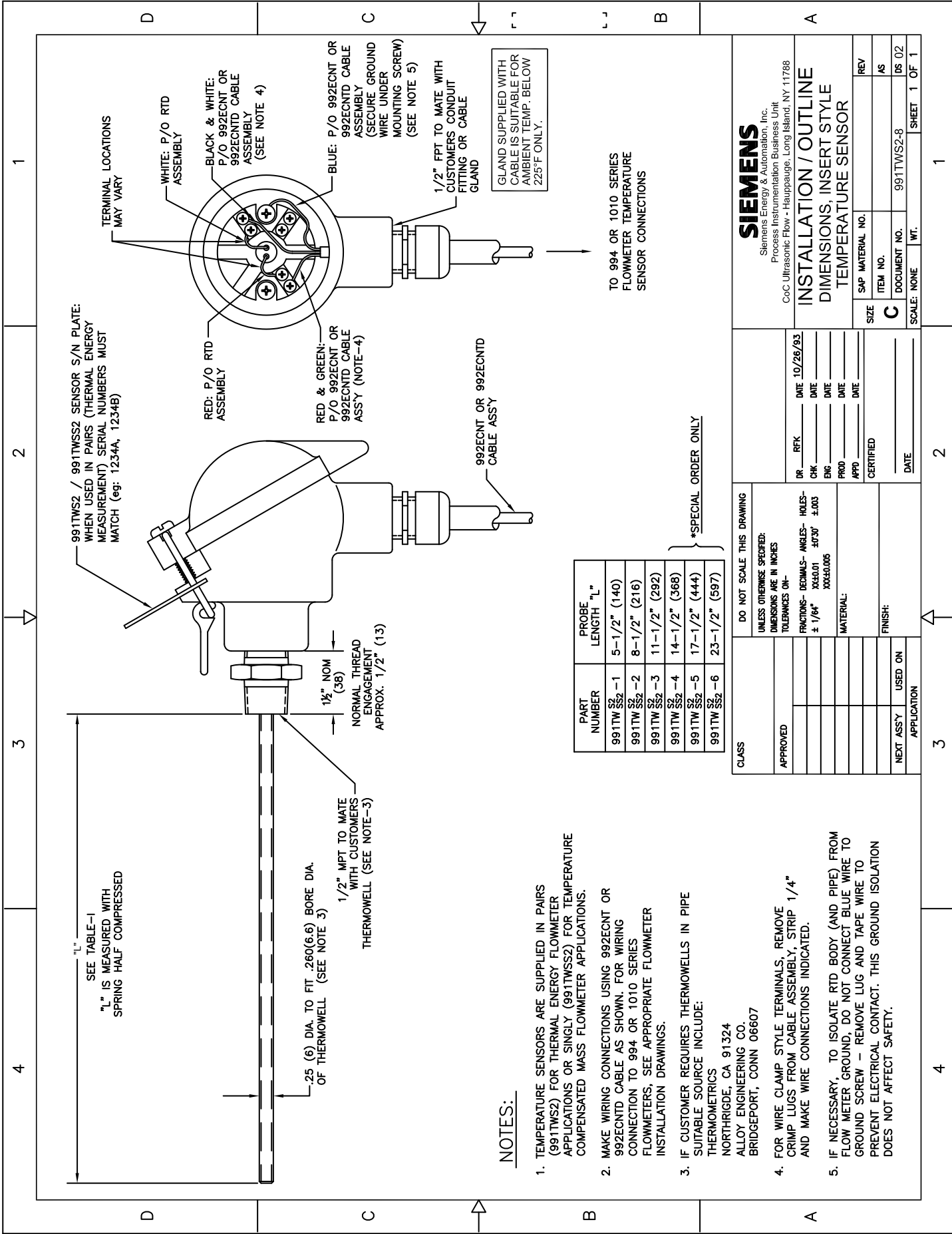

**NOTES:**

- TEMPERATURE SENSORS ARE SUPPLIED IN PAIRS (991TWS2) FOR THERMAL ENERGY FLOWMETER APPLICATIONS OR SINGLY (991TWS22) FOR TEMPERATURE COMPENSATED MASS FLOWMETER APPLICATIONS.
- MAKE WIRING CONNECTIONS USING 992ECNT OR 992ECNTD CABLE AS SHOWN. FOR WIRING CONNECTION TO 994 OR 1010 SERIES FLOWMETERS, SEE APPROPRIATE FLOWMETER INSTALLATION DRAWINGS.
- IF CUSTOMER REQUIRES THERMOWELLS IN PIPE SUITABLE SOURCE INCLUDE:  
NORTHRIE, CA 91324  
ALLOY ENGINEERING CO.  
BRIDGEPORT, CONN 06607
- FOR WIRE CLAMP STYLE TERMINALS, REMOVE CRIMP LUGS FROM CABLE ASSEMBLY, STRIP 1/4" AND MAKE WIRE CONNECTIONS INDICATED.
- IF NECESSARY, TO ISOLATE RTD BODY (AND PIPE) FROM FLOW METER GROUND, DO NOT CONNECT BLUE WIRE TO GROUND SCREW - REMOVE LUG AND TAPE WIRE TO PREVENT ELECTRICAL CONTACT. THIS GROUND ISOLATION DOES NOT AFFECT SAFETY.

**SIEMENS**  
Siemens Energy & Automation, Inc.  
Process Instrumentation Business Unit  
CoC Ultrasonic Flow - Hauppauge, Long Island, NY 11788

**INSTALLATION / OUTLINE DIMENSIONS, INSERT STYLE TEMPERATURE SENSOR**

DR	REF	DATE	10/26/93
CHK		DATE	
ENG		DATE	
PRD		DATE	
APPD		DATE	
CERTIFIED			
DATE			

SIZE: \_\_\_\_\_  
SAP MATERIAL NO.: \_\_\_\_\_  
ITEM NO.: \_\_\_\_\_  
DOCUMENT NO.: 991TWS2-8  
SCALE: NONE WT. SHEET 1 OF 1

- INSTALLATION PROCEDURE** - SEE DRAWING REFERENCE **A**
- INSTALLATION OF THE DEDICATED NEMA 4 TEMPERATURE SENSOR FOR PIPES 1 1/4" - 48" DIAMETER CONSISTS OF THE FOLLOWING: THE SENSOR P/N 991TDS2/991TDS2 WITH INTEGRAL CABLE AND JUNCTION BOX, A CABLE 992EC-(LENGTH), AND MOUNTING ASSY 992EMIN(-2,-3 OR -4).
  - SELECT THE PIPE LOCATION WHERE TEMPERATURE IS TO BE MONITORED IN ACCORDANCE WITH RECOMMENDATIONS IN THE FIELD MANUAL.
  - CLEAN A SMALL AREA OF PIPE SURFACE (APPROXIMATELY 1" DIAMETER); REMOVE PAINT, SCALE, FOREIGN MATTER THAT CAN AFFECT GOOD THERMAL CONTACT.
  - CENTER THE MOUNTING NUT (PART OF 992EMIN) OVER THE CLEAN SPOT AND STRAP IN PLACE. ALLOW THE STRAP TO REACH APPROXIMATELY THE TEMPERATURE OF THE PIPE AND TIGHTEN SECURELY.
  - SPIN THE JAM NUT (PART OF 992EMIN) ONTO THE SENSOR BODY (991TDS2 OR 991TDS2). APPLY A GENEROUS AMOUNT OF THERMAL COMPLANT (SUPPLIED WITH 992EMIN) TO THE FACE OF THE SENSOR AND SCREW IT INTO THE MOUNTING NUT. HAND TIGHT ENGAGEMENT IS SUFFICIENT. SECURE THE SENSOR BY TIGHTENING THE JAM NUT AGAINST THE MOUNTING NUT.
  - SELECT A MOUNTING LOCATION FOR THE JUNCTION BOX USE INTEGRAL MOUNTING HOLES OR SECURE AT END OF RIGID CONDUIT. IF CONDUIT IS USED, REMOVE THE WATER-TIGHT GLAND SUPPLIED WITH THE JUNCTION BOX. INSTALL THE 992EC CABLE, MAKING WIRING CONNECTIONS 1-5 AS SHOWN.
  - AFTER TEMPERATURE SENSOR HAS BEEN POSITIONED PROPERLY, PROTECTIVELY ENCAPSULATE IT AS FOLLOWS: PACK "DENSO" MASTIC AROUND TEMPERATURE SENSOR. SURFACE OF PIPE AND MOUNTING STRAP SHOULD BE CLEAN AND RUBBED WITH "DENSO" PASTE BEFORE WRAPPING. WRAP "DENSO" TAPE AROUND PIPE, STRAP AND TEMPERATURE SENSOR. SMOOTH THE TAPE SURFACE AFTER WRAPPING.
  - MAKE CABLE CONNECTIONS TO THE 994 OR 1010 SERIES FLOWMETER IN ACCORDANCE WITH THE APPROPRIATE FLOWMETER INSTALLATION DRAWING.
  - STANDARD TEMPERATURE SENSOR CABLE AND JUNCTION BOX IS PART NUMBER 992EC-(LENGTH) FOR PLENUM RATED CABLE ASSEMBLIES, USE CABLE PART NUMBER 992EC00-(LENGTH)

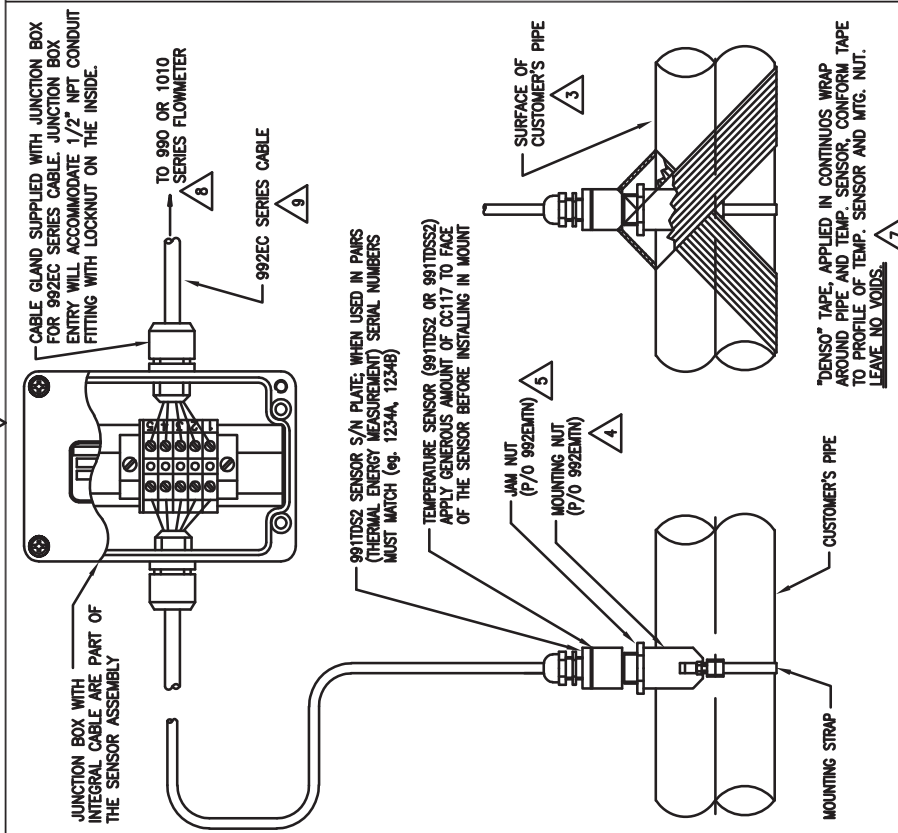

- NOTES:**
- TO AID INSTALLATION, THE TEMP. SENSOR CABLE MAY BE DISCONNECTED FROM THE CABLE JUNCTION. THE CAP RING AND SEALING GLAND REMAIN ON CABLE.
  - EACH TEMP SENSOR WRAP KIT CONSISTS OF:
    - 1-ROLL OF 2" WIDE "DENSO" TAPE
    - 1-1/2" BLOCK OF "DENSO" MASTIC
    - 1-1/2" CONTAINER OF "DENSO" PASTE (P/N 991-82).

- INSTALLATION PROCEDURE** - SEE DRAWING REFERENCE **A**
- TO AID INSTALLATION, THE TEMP. SENSOR CABLE MAY BE DISCONNECTED FROM THE CABLE JUNCTION. THE CAP RING AND SEALING GLAND REMAIN ON CABLE.
  - EACH TEMP SENSOR WRAP KIT CONSISTS OF:
    - 1-ROLL OF 2" WIDE "DENSO" TAPE
    - 1-1/2" BLOCK OF "DENSO" MASTIC
    - 1-1/2" CONTAINER OF "DENSO" PASTE (P/N 991-82).

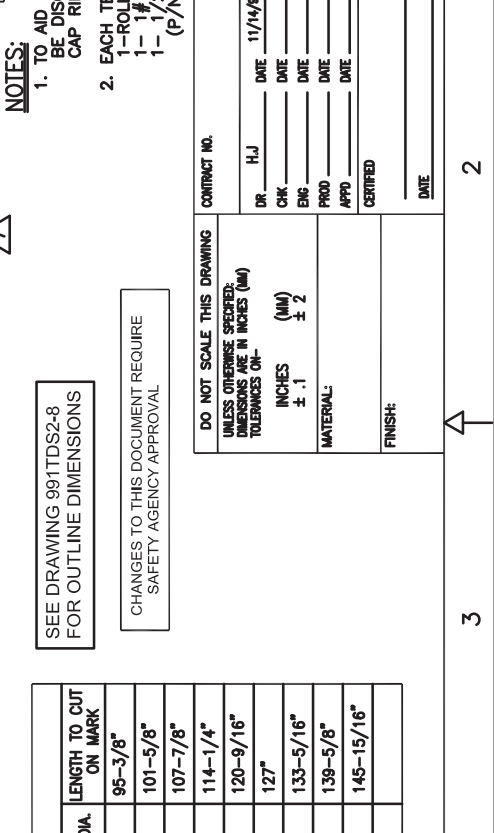

- INSTALLATION PROCEDURE** - SEE DRAWING REFERENCE **A**
- TO AID INSTALLATION, THE TEMP. SENSOR CABLE MAY BE DISCONNECTED FROM THE CABLE JUNCTION. THE CAP RING AND SEALING GLAND REMAIN ON CABLE.
  - EACH TEMP SENSOR WRAP KIT CONSISTS OF:
    - 1-ROLL OF 2" WIDE "DENSO" TAPE
    - 1-1/2" BLOCK OF "DENSO" MASTIC
    - 1-1/2" CONTAINER OF "DENSO" PASTE (P/N 991-82).

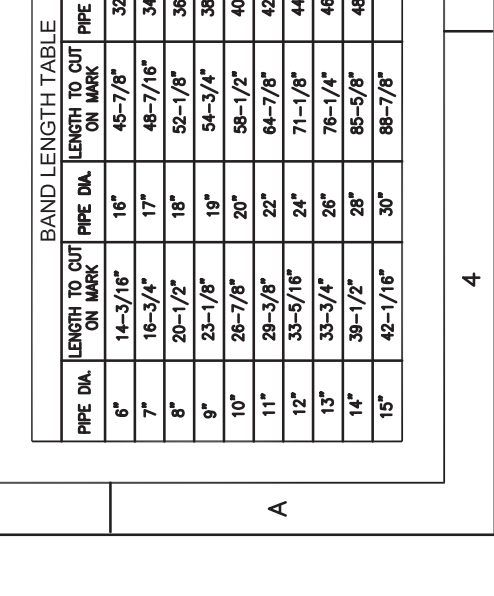

**INSTALLATION PROCEDURE**

**INSTALLATION PROCEDURE**

**INSTALLATION PROCEDURE**

**INSTALLATION PROCEDURE**

**INSTALLATION PROCEDURE**

**INSTALLATION PROCEDURE**

**INSTALLATION PROCEDURE**

**INSTALLATION PROCEDURE**

**INSTALLATION PROCEDURE**

**INSTALLATION PROCEDURE**

**INSTALLATION PROCEDURE**

**INSTALLATION PROCEDURE**

**INSTALLATION PROCEDURE**

**INSTALLATION PROCEDURE**

**INSTALLATION PROCEDURE**

**INSTALLATION PROCEDURE**

**INSTALLATION PROCEDURE**

**INSTALLATION PROCEDURE**

**INSTALLATION PROCEDURE**

**INSTALLATION PROCEDURE**

**INSTALLATION PROCEDURE**

**INSTALLATION PROCEDURE**

**INSTALLATION PROCEDURE**

**INSTALLATION PROCEDURE**

**INSTALLATION PROCEDURE**

**INSTALLATION PROCEDURE**

**INSTALLATION PROCEDURE**

**INSTALLATION PROCEDURE**

**INSTALLATION PROCEDURE**

**INSTALLATION PROCEDURE**

**INSTALLATION PROCEDURE**

**INSTALLATION PROCEDURE**

**INSTALLATION PROCEDURE**

**INSTALLATION PROCEDURE**

**INSTALLATION PROCEDURE**

**INSTALLATION PROCEDURE**

**INSTALLATION PROCEDURE**

**INSTALLATION PROCEDURE**

**INSTALLATION PROCEDURE**

**INSTALLATION PROCEDURE**

**INSTALLATION PROCEDURE**

**INSTALLATION PROCEDURE**

**INSTALLATION PROCEDURE**

**INSTALLATION PROCEDURE**

**INSTALLATION PROCEDURE**

**INSTALLATION PROCEDURE**

**INSTALLATION PROCEDURE**

**INSTALLATION PROCEDURE**

**INSTALLATION PROCEDURE**

**INSTALLATION PROCEDURE**

**INSTALLATION PROCEDURE**

**INSTALLATION PROCEDURE**

**INSTALLATION PROCEDURE**

**INSTALLATION PROCEDURE**

**INSTALLATION PROCEDURE**

**INSTALLATION PROCEDURE**

**INSTALLATION PROCEDURE**

**INSTALLATION PROCEDURE**

**INSTALLATION PROCEDURE**

**INSTALLATION PROCEDURE**

**INSTALLATION PROCEDURE**

**INSTALLATION PROCEDURE**

**INSTALLATION PROCEDURE**

**INSTALLATION PROCEDURE**

**INSTALLATION PROCEDURE**

**INSTALLATION PROCEDURE**

**INSTALLATION PROCEDURE**

**INSTALLATION PROCEDURE**

**INSTALLATION PROCEDURE**

**INSTALLATION PROCEDURE**

**INSTALLATION PROCEDURE**

**INSTALLATION PROCEDURE**

**INSTALLATION PROCEDURE**

**INSTALLATION PROCEDURE**

**INSTALLATION PROCEDURE**

**INSTALLATION PROCEDURE**

**INSTALLATION PROCEDURE**

**INSTALLATION PROCEDURE**

**INSTALLATION PROCEDURE**

**INSTALLATION PROCEDURE**

**INSTALLATION PROCEDURE**

**INSTALLATION PROCEDURE**

**INSTALLATION PROCEDURE**

**INSTALLATION PROCEDURE**

**INSTALLATION PROCEDURE**

**INSTALLATION PROCEDURE**

**INSTALLATION PROCEDURE**

**INSTALLATION PROCEDURE**

**INSTALLATION PROCEDURE**

**INSTALLATION PROCEDURE**

**INSTALLATION PROCEDURE**

**INSTALLATION PROCEDURE**

**INSTALLATION PROCEDURE**

**INSTALLATION PROCEDURE**

**INSTALLATION PROCEDURE**

**INSTALLATION PROCEDURE**

**INSTALLATION PROCEDURE**

**INSTALLATION PROCEDURE**

**INSTALLATION PROCEDURE**

**INSTALLATION PROCEDURE**

**INSTALLATION PROCEDURE**

**INSTALLATION PROCEDURE**

**INSTALLATION PROCEDURE**

**INSTALLATION PROCEDURE**

**INSTALLATION PROCEDURE**

**INSTALLATION PROCEDURE**

**INSTALLATION PROCEDURE**

**INSTALLATION PROCEDURE**

**INSTALLATION PROCEDURE**

**INSTALLATION PROCEDURE**

**INSTALLATION PROCEDURE**

**INSTALLATION PROCEDURE**

**INSTALLATION PROCEDURE**

**INSTALLATION PROCEDURE**

**INSTALLATION PROCEDURE**

**INSTALLATION PROCEDURE**

**INSTALLATION PROCEDURE**

**INSTALLATION PROCEDURE**

**INSTALLATION PROCEDURE**

**INSTALLATION PROCEDURE**

**INSTALLATION PROCEDURE**

**INSTALLATION PROCEDURE**

**INSTALLATION PROCEDURE**

**INSTALLATION PROCEDURE**

**INSTALLATION PROCEDURE**

**INSTALLATION PROCEDURE**

**INSTALLATION PROCEDURE**

**INSTALLATION PROCEDURE**

**INSTALLATION PROCEDURE**

**INSTALLATION PROCEDURE**

**INSTALLATION PROCEDURE**

**INSTALLATION PROCEDURE**

**INSTALLATION PROCEDURE**

**INSTALLATION PROCEDURE**

**INSTALLATION PROCEDURE**

**INSTALLATION PROCEDURE**

**INSTALLATION PROCEDURE**

**INSTALLATION PROCEDURE**

**INSTALLATION PROCEDURE**

**INSTALLATION PROCEDURE**

**INSTALLATION PROCEDURE**

**INSTALLATION PROCEDURE**

**INSTALLATION PROCEDURE**

**INSTALLATION PROCEDURE**

**INSTALLATION PROCEDURE**

**INSTALLATION PROCEDURE**

**INSTALLATION PROCEDURE**

**INSTALLATION PROCEDURE**

**INSTALLATION PROCEDURE**

**INSTALLATION PROCEDURE**

**INSTALLATION PROCEDURE**

**INSTALLATION PROCEDURE**

**INSTALLATION PROCEDURE**

**INSTALLATION PROCEDURE**

**INSTALLATION PROCEDURE**

**INSTALLATION PROCEDURE**

**INSTALLATION PROCEDURE**

**INSTALLATION PROCEDURE**

**INSTALLATION PROCEDURE**

**INSTALLATION PROCEDURE**

**INSTALLATION PROCEDURE**

**INSTALLATION PROCEDURE**

**INSTALLATION PROCEDURE**

**INSTALLATION PROCEDURE**

**INSTALLATION PROCEDURE**

**INSTALLATION PROCEDURE**

**INSTALLATION PROCEDURE**

**INSTALLATION PROCEDURE**

**INSTALLATION PROCEDURE**

**INSTALLATION PROCEDURE**

**INSTALLATION PROCEDURE**

**INSTALLATION PROCEDURE**

**INSTALLATION PROCEDURE**

**INSTALLATION PROCEDURE**

**INSTALLATION PROCEDURE**

**INSTALLATION PROCEDURE**

**INSTALLATION PROCEDURE**

**INSTALLATION PROCEDURE**

**INSTALLATION PROCEDURE**

**INSTALLATION PROCEDURE**

**INSTALLATION PROCEDURE**

**INSTALLATION PROCEDURE**

**INSTALLATION PROCEDURE**

**INSTALLATION PROCEDURE**

**INSTALLATION PROCEDURE**

**INSTALLATION PROCEDURE**

**INSTALLATION PROCEDURE**

**INSTALLATION PROCEDURE**

**INSTALLATION PROCEDURE**

**INSTALLATION PROCEDURE**

**INSTALLATION PROCEDURE**

**INSTALLATION PROCEDURE**

**INSTALLATION PROCEDURE**

**INSTALLATION PROCEDURE**

**INSTALLATION PROCEDURE**

**INSTALLATION PROCEDURE**

**INSTALLATION PROCEDURE**

**INSTALLATION PROCEDURE**

**INSTALLATION PROCEDURE**

**INSTALLATION PROCEDURE**

**INSTALLATION PROCEDURE**

**INSTALLATION PROCEDURE**

**INSTALLATION PROCEDURE**

**INSTALLATION PROCEDURE**

**INSTALLATION PROCEDURE**

**INSTALLATION PROCEDURE**

**INSTALLATION PROCEDURE**

**INSTALLATION PROCEDURE**

**INSTALLATION PROCEDURE**

**INSTALLATION PROCEDURE**

**INSTALLATION PROCEDURE**

**INSTALLATION PROCEDURE**

**INSTALLATION PROCEDURE**

**INSTALLATION PROCEDURE**

**INSTALLATION PROCEDURE**

**INSTALLATION PROCEDURE**

**INSTALLATION PROCEDURE**

**INSTALLATION PROCEDURE**

**INSTALLATION PROCEDURE**

**INSTALLATION PROCEDURE**



**INSTALLATION PROCEDURE** - SEE DRAWING REFERENCES  $\Delta$

- SELECT MOUNTING LOCATION / PREPARE PIPE:  
SELECT A SECTION OF PIPE THAT REMAINS FULL AT ALL FLOW RATES. REMOVE ANY EXTERNAL CORROSION OR LOOSE PAINT AND PREPARE A CLEAN, SMOOTH MOUNTING SPACE ON THE PIPE, OF APPROXIMATELY THE SIZE SHOWN.
- CHOOSE THE APPROPRIATE TRANSDUCER MOUNTING ARRANGEMENT:  
IF THE LIQUID TO BE MEASURED CONTAINS A REASONABLE AMOUNT OF PARTICULATE MATTER (FOR EXAMPLE A "SLURRY") THEN THE "IN-LINE" TRANSDUCER CONFIGURATION IS RECOMMENDED. IF THE LIQUID TO BE MEASURED CONTAINS A SMALL AMOUNT OF PARTICULATE MATTER, OR IF ENHANCED FLOW PROFILE AVERAGING IS REQUIRED, THEN THE "DUAL-HEAD" CONFIGURATION IS RECOMMENDED BECAUSE OF ITS ABILITY TO INCREASE TRANSDUCER SENSITIVITY.
- CONFIGURATION OF THE TRANSDUCERS FOR "IN-LINE" MODE:  
MOUNT TRANSDUCERS INDIVIDUALLY, EACH WITH ITS OWN METAL STRAP POSITION IN LINE AS CLOSE AS PRACTICAL. BOTH ORIENTATION MARKS MUST FACE THE SAME DIRECTION. RELATIVE POSITION OF THE "XMIT" AND "RCV" TRANSDUCERS IS DETERMINED BY PIPE MATERIAL. NOTE THE DIFFERENCE IN MOUNTING FOR METAL AND PLASTIC PIPES.
- CONFIGURATION OF THE TRANSDUCERS FOR "DUAL-HEAD" MODE:  
USING A SINGLE METAL STRAP TO MOUNT BOTH TRANSDUCERS ON THE PIPE. BOTH ORIENTATION MARKS MUST FACE THE SAME DIRECTION. THE RELATIVE POSITION OF "XMIT" AND "RCV" TRANSDUCERS DOES NOT MATTER WHEN USED IN THE "DUAL-HEAD" MODE.
- LOOSEN FEMALE SWIVEL FITTING (2-PLCS.) AND TEMPORARILY MOUNT THE TRANSDUCERS IN THE SELECTED CONFIGURATION AT CHOSEN LOCATION. CONNECT THE CABLES AS SHOWN AT THE JUNCTION BOX AND THE FLOW COMPUTER. ONCE SATISFACTORY OPERATION HAS BEEN ESTABLISHED, CHOOSE ONE OF THE MOUNTING OPTIONS DESCRIBED ON DRAWING 191NH-8 AND PERMANENTLY INSTALL THE JUNCTION BOX. INSTALL CABLES (CONDUITS) IN ACCORDANCE WITH LOCAL REQUIREMENTS. TIGHTEN FEMALE SWIVEL FITTING (2-PLCS.).
- REMOVE AND CLEAN THE TRANSDUCERS THEN RE-INSTALL AT THE SAME LOCATIONS WITH THE PERMANENT ULTRASONIC COUPLANT SUPPLIED.
- SEE DRAWING 191NH-8 FOR OUTLINE DIMENSIONS.
- SEE DRAWING 194N-7 FOR FLOW COMPUTER INSTALLATION INFORMATION AND 194N-8 FOR FLOW COMPUTER OUTLINE DIMENSIONS.

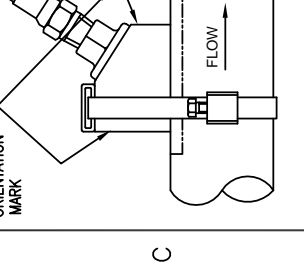
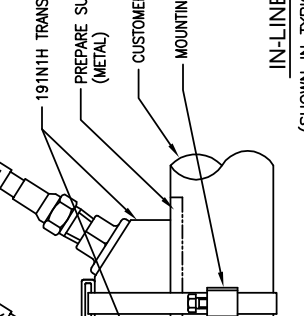
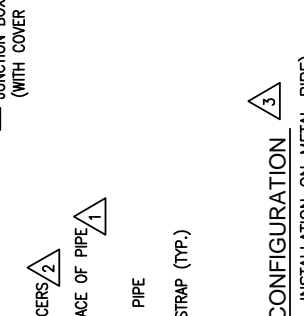
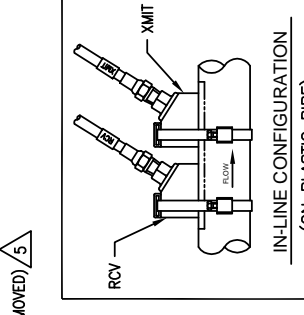
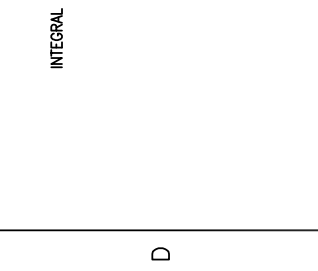
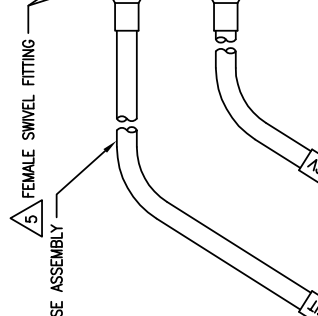
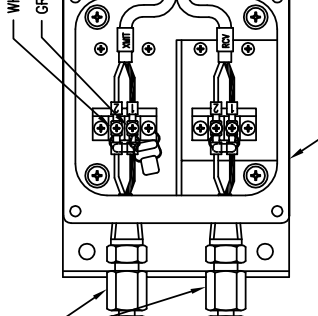
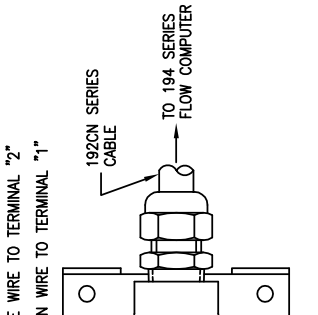

**PIPE PREPARATION**  $\Delta$

DO NOT SCALE THIS DRAWING  
UNLESS OTHERWISE SPECIFIED:  
DIMENSIONS ARE IN INCHES (MM)  
TOLERANCES ON:  
INCHES (MM)  
 $\pm .1$  ( $\pm 2$ )

CONTRACT NO. \_\_\_\_\_  
DR H-J \_\_\_\_\_ DATE 1/12/00  
CHK \_\_\_\_\_ DATE \_\_\_\_\_  
ENG \_\_\_\_\_ DATE \_\_\_\_\_  
PRD \_\_\_\_\_ DATE \_\_\_\_\_  
APPD \_\_\_\_\_ DATE \_\_\_\_\_  
CERTIFIED \_\_\_\_\_

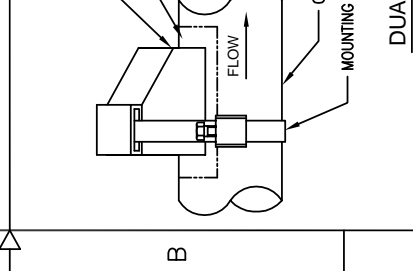
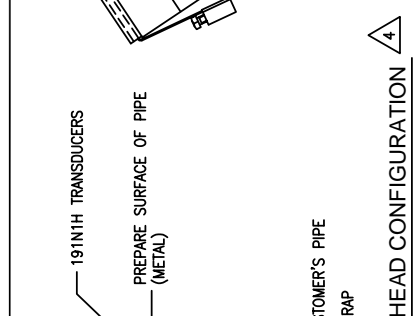
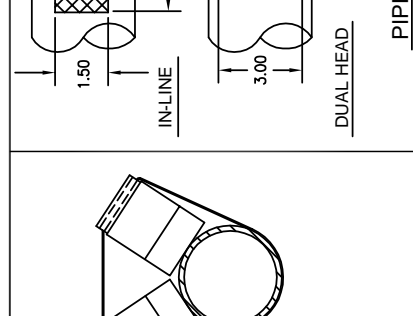
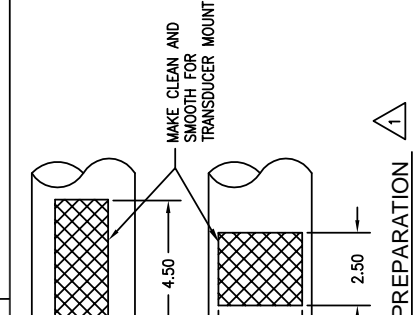

**CONTROLTRON**  
HAUPPAUGE, NY 11788

Installation Drawing,  
191NH Transducer,  
High Temp, NEMA 4

SIZE CODE IDENT NO. **C 21614** 191NH-7 REV. **B**

SCALE: NONE | WT. \_\_\_\_\_ SHEET 1 OF 1

R14: 191NH - 7 sht.1 rev.B

APPLY A THIN BAND OF COUPLANT TO BASE OF EACH TRANSDUCER BEFORE INSTALLING ON PIPE

USE OF COUPLANT COMPOUND  $\Delta$

USE OF COUPLANT COMPOUND  $\Delta$

USE OF COUPLANT COMPOUND  $\Delta$







# STAINLESS STEEL, HASTELLOY "C" & TITANIUM PIPE

Sched.	Size	1/2	3/4	1	1 1/4	1 1/2	2	2 1/2	3	3 1/2	4	5	6	8	10	12	14	16	18	20	22	24	
5S	O.D.	0.840	1.050	1.315	1.660	1.900	2.375	2.875	3.500	4.000	4.500	5.563	6.625	8.625	10.750	12.750	14.000	16.000	18.000	20.000	22.000	24.000	
	I.D.	0.710	0.920	1.185	1.530	1.770	2.245	2.709	3.334	3.834	4.334	5.345	6.407	8.407	10.482	12.438	13.688	15.670	17.670	19.634	21.624	23.563	
	Wall	0.065	0.065	0.065	0.065	0.065	0.083	0.083	0.083	0.083	0.083	0.109	0.109	0.109	0.134	0.156	0.156	0.165	0.165	0.188	0.188	0.218	
10S	I.D.	0.674	0.884	1.097	1.442	1.682	2.157	2.635	3.260	3.760	4.260	5.295	6.357	8.329	10.420	12.390	13.624	15.624	17.624	19.564	21.564	23.500	
	Wall	0.083	0.083	0.109	0.109	0.109	0.120	0.120	0.120	0.120	0.120	0.134	0.134	0.148	0.165	0.180	0.188	0.188	0.188	0.218	0.218	0.250	
	I.D.	0.622	0.824	1.049	1.380	1.610	2.067	2.469	3.068	3.548	4.026	5.047	6.065	7.981	10.020	12.000							
40S	Wall	0.109	0.113	0.133	0.140	0.145	0.154	0.203	0.216	0.226	0.237	0.258	0.280	0.322	0.365	0.375							
	I.D.	0.546	0.742	0.957	1.278	1.500	1.939	2.323	2.900	3.364	3.826	4.813	5.761	7.625	9.750	11.750	13.000	15.000	17.000	19.000	21.000	23.000	25.000
	Wall	0.147	0.154	0.179	0.191	0.200	0.218	0.276	0.300	0.318	0.337	0.375	0.432	0.500	0.500	0.500	0.500	0.500	0.500	0.500	0.500	0.500	0.500
80S	I.D.	0.252	0.434	0.599	0.896	1.100	1.503	1.771	2.300	2.728	3.152	4.063	4.897	6.875	8.750	10.750							
	Wall	0.294	0.308	0.358	0.400	0.436	0.552	0.600	0.636	0.674	0.750	0.864	0.875	1.000	1.000								
	I.D.																						

# CARBON STEEL and PVC PIPE

Pipe	Size	1/2	3/4	1	1 1/4	1 1/2	2	2 1/2	3	3 1/2	4	5	6	8	10	12	14	16	18	20	22	24	26	28	30	32	34	36	42
Stand-ard	O.D.	0.840	1.050	1.315	1.660	1.900	2.375	2.875	3.500	4.000	4.500	5.563	6.625	8.625	10.750	12.750	14.000	16.000	18.000	20.000	22.000	24.000	26.000	28.000	30.000	32.000	34.000	36.000	42.000
	I.D.	0.622	0.824	1.049	1.380	1.610	2.067	2.469	3.068	3.548	4.026	5.047	6.065	7.981	10.020	12.000	13.250	15.250	17.250	19.250	21.250	23.250	25.250	27.250	29.250	31.250	33.250	35.250	41.250
	Wall	0.109	0.113	0.133	0.140	0.145	0.203	0.216	0.226	0.237	0.258	0.280	0.322	0.365	0.375	0.375	0.375	0.375	0.375	0.375	0.375	0.375	0.375	0.375	0.375	0.375	0.375	0.375	0.375
Extra Strong (XS)	I.D.	0.546	0.742	0.957	1.278	1.500	1.939	2.323	2.900	3.364	3.826	4.813	5.761	7.625	9.750	11.750	13.000	15.000	17.000	19.000	21.000	23.000	25.000	27.000	29.000	31.000	33.000	35.000	41.000
	Wall	0.147	0.154	0.179	0.191	0.200	0.218	0.276	0.300	0.318	0.337	0.375	0.432	0.500	0.500	0.500	0.500	0.500	0.500	0.500	0.500	0.500	0.500	0.500	0.500	0.500	0.500	0.500	0.500
	I.D.	0.252	0.434	0.599	0.896	1.100	1.503	1.771	2.300	2.728	3.152	4.063	4.897	6.875	8.750	10.750													
Double Extra (XXS)	Wall	0.294	0.308	0.358	0.400	0.436	0.552	0.600	0.636	0.674	0.750	0.864	0.875	1.000	1.000														
	I.D.																												
	Wall																												
Sched. 10	I.D.																												
	Wall																												
	I.D.																												
Sched. 20	I.D.																												
	Wall																												
	I.D.																												
Sched. 30	I.D.																												
	Wall																												
	I.D.																												
Sched. 40	I.D.																												
	Wall																												
	I.D.																												
Sched. 60	I.D.																												
	Wall																												
	I.D.																												
Sched. 80	I.D.																												
	Wall																												
	I.D.																												
Sched. 100	I.D.																												
	Wall																												
	I.D.																												
Sched. 120	I.D.																												
	Wall																												
	I.D.																												
Sched. 140	I.D.																												
	Wall																												
	I.D.																												
Sched. 160	I.D.																												
	Wall																												
	I.D.																												

# NON-STANDARD CARBON

Size	10	20	24
O.D.	10.750	20.000	24.000
I.D.	10.192	19.375	23.375
Wall	0.279	0.312	0.312

The above sizes are produced by pipe mills but dimensions do not conform to any regular standard or schedule.

- △ These materials are generally available in Schedules 40 and 80 only.
- ◇ Wall Thickness of Schedule 5S & 10S does not permit threading in accordance with the American Standard for Pipe Threads (ASA No. B2.1)
- ⊗ Wall thickness identical with thickness of "Standard Weight" pipe.
- ▲ Wall Thickness identical with thickness of "Extra-Heavy" pipe.
- \* These do not conform to American Standard B36. 10.

PIPE WEIGHT FORMULA FOR STEEL PIPE (lbs per foot)
10.68 (D-t), where D=Outside Diameter and t=Wall Thickness



Siemens Industry Inc.  
Industry Automation Division  
Coc Ultrasonic Flow  
Hauptpage, New York 11788 USA  
Web: www.usa.siemens.com

# Glossary

## Active Memory

Section of RAM allocated for active site parameters (all current values). The flow meter receives site-specific operating instructions from Active Memory.

## Alphanumeric Field

An 8-character data entry field that allows you to specify a Site Name or a Security code.

## Arrow Keys

Use the <Up, Down, Left and Right> Arrows to navigate through the Installation Menu in their respective directions. The <Up or Down> Arrows allow you also to scroll through option list items.

## Asterisk

Refers to the marker used in the Installation Menu to indicate a current option list selection. When you access an option list, you can move the asterisk with the <Up or Down> Arrows to a new selection, then press <ENTER> to select the item.

## CLR (Clear) Key

Use the <CLR> key to erase a numeric value or clear a selection from a multiple select option list.

## Cursor

This refers to the highlighted text and the arrow cursor that you move via the arrow direction when navigating through menus or menu cells.

## Data Entry

Refers to data entered into a menu cell (either numeric or option list selection).

## Datalogger Memory

Memory segment that stores data items logged during operation. You can view the Datalogger contents either on-screen or transmit it to an external device via the RS-232 serial port. The amount of Datalogger memory depends on how many sites reside in Site Storage memory.

**ENTER Key**

Use the <ENTER> key to store a current numeric value or option list item.

**Flow Meter**

Refers to the flow meter itself (the transmitter and sensors combined).

**Graphic Screen**

Refers to the integral LCD display screen.

**Initial Makeup**

An internal process performed during installation, where the flow meter acquires its receive signal and enhances other parameters for optimal operation at a site.

**In-process Makeup**

An internal process where the flow meter recovers its Initial Makeup parameters after a fault condition interrupts operation.

**Installation Menu**

The flow meter's overall menu structure. It allows you to define all aspects of operation for the flow meter.

**Interface m/s**

Refers to an alarm function that declares the passage of a liquid or gas interface by a comparison analysis of the relative sonic velocities of the two liquids or two gases.

**LAPTOT**

Refers to a system function that freezes the Totalizer display, while the Totalizer continues to update its registers.

**Local Display**

Refers to the transmitter integral display screen.

**Menu**

Sub-sections of the Installation Menu that allow you to define specific operational functions (e.g., RS-232 Setup).

**Menu Cell**

A location within a menu where you can define either a single numeric value or option list selection that supports the Sub-Menu's function. Certain view-only menu cells show reference data appropriate to the current application.

**NEGFLOW**

Totalizer mode for negative flow total only.

**NETFLOW**

Totalizer mode that combines positive and negative flow totals.

**NOTOT**

System function that disables the internal Totalizer.

**Number Index**

Computed sensor spacing index based on the estimated sonic velocity measurement. This Index can not be overridden by installer.

**Numeric Data**

Refers to a value entered into a menu cell. An example would be the pipe outer diameter.

**Numeric Entry**

Refers to a number you type into menu cell that stores numeric data.

**Numeric Keys**

Use the Numeric keys to type a numeric value where appropriate.

**Op Sys ROM**

The Read-Only-Memory that stores the basic operating instructions and permanent defaults of the flow meter's operating system.

**Option List**

Lists of options presented at menu cells that allow you to select either a single item or multiple items (depending on the function that the menu cell controls).

**Parameters**

Refers to value (either numeric or list selection) stored in a menu cell.

**POSFLOW**

Totalizer mode for positive flow total only.

**Register**

Refers to a memory location used by the flow meter to store data such as the flow total, etc.

**RTD**

Resistive Temperature Device. Temperature sensors used with energy flow of mass flow systems.

**Sensor**

Refers to entire spool piece, in some instances. Also flow sensors that the flow meter uses to measure the flow rate. Also called transducers and abbreviated as Xdcr.

**Site Name**

A user-entered name that the flow meter associates with a stored Site Setup. You retrieve a particular Site by selecting its name from a site name list.

**Site Setup**

A collection of parameters used by the flow meter to service a specific site (or location). The flow meter allows you to store several independent Site Setups.

**Site Storage Memory**

Section of RAM allocated for permanent data storage. This memory segment stores inactive site setups (including a backup of active site). The flow meter's Site Setup storage capacity depends on the dynamic memory allocation as dictated by each application. In addition, the flow meter uses Site Storage Memory to store configurable operating parameters such as pipe, liquid or gas tables.

**Si-Ware**

Siemens software program that interfaces with Siemens flow meters to assess flow meter installation conditions and to collect data for comparison with prior baseline data.

**Spacing Index**

Refers to the Number Index used by the flow meter to determine the space between the upstream and downstream sensors on clamp-on systems.

**Spacing Offset**

Fixed sensor offset assigned by the flow meter. This can be overridden by the installer.

**TOTCNT**

A Totalizer pulse count function used for Batching or Sampling.

**Transducer**

Also known as sensor.

**Vaer**

The flow meter's aeration percent output.

**Vps**

The sonic propagation velocity of a pipe.

**Vs**

The sonic velocity of a liquid or gas.





# Index

## 1

1012T Sensor Mounting Tracks  
Direct Mode, 68  
Reflect Mode, 66

## 2

2-Channel, 26  
2-Path, 26

## A

Actual MTY Command, 85  
Actual Zero, 74  
Alarm Codes, 137  
Analog Input Setup, 113  
    Setting DC current input, 114  
Analog Out Setup, 110  
Analog Out Trim, 117  
    Current Output Trim, 119  
    Pgen Output Trim, 121  
    Voltage Output Trim, 120  
AutoZero, 74

## B

Basic Requirements, 30

## C

CE marked equipment, 13  
CE-mark, 13  
Channel 3  
    Virtual channel, 27  
Connecting Sensors to the Transmitter, 80  
Customer Support Hotline, 139

## D

Damping Control, 104  
Data Output Filters  
    SmartSlew, Time Average, 104

## Datalogger

Circular Memory, 103  
Clear Logger data, 103  
Control menu, 100  
Display screen setup, 101  
Est LogTime Left, 103  
RS-232 output, 102

## Deadband Controls, 105

## Decontamination, 140

## Device inspection, 9

Digital Damping Control:(Hot Key 1 and 2), 149

## E

## Empty Pipe Set, 85

## Energy

CE Method, 115  
Coefficient of Performance (COP), 115  
Energy Efficiency Ratio (EER), 116  
KW/ton, 115  
PckW Menu Cell, 115

## Energy AnCal, 117

## Energy AnCal Menu, 117

## F

## F4 Reset, 146

Clearing Active Memory, 146  
Clearing All Saved Memory, 146

## Flow meter Types, 25

## Flow Profile Compensation, 24

## Flow Rate

Calibration Methods, 199  
Calibration Tables, installation, 201  
Intrinsic Calibration (factory), 199  
Kc Calibration (Slope Correction), 200

## H

## Hazardous area safety requirements, 15

## History, 10

## Hotline, 139

## I

## Installation

- Safety instructions, 29
- Installation Menu
  - Navigating and Keypad functions, 43
- Installation Menu Chart, 87
- Installation/Outline Drawings, 203
- Internet
  - Contact person, 140
  - Support, 139

## L

- Language
  - Selecting, 45
- Liquid Class
  - Selecting, 47
- Lithium batteries
  - Safety, 13
- Location and Service
  - Selecting, 48
- Logger Control, 100
- Ltn Menu Cell, 58

## M

- Maintenance, 139
- Memory Control Menu, 109
  - Defragment, 110
  - Log Memory Left, 109
  - Memory Map, 110
- Memory Delay, 106
- Memory/Fault Set, 106
- Meter Type
  - Selecting, 45
- Model Numbers, 22
- MTYmatic Command, 86

## P

- Pipe Configuration
  - Selecting, 48
- Pipe Data
  - Selecting, 47
- Pipe Mounting, 31
- Preliminary Procedures
  - Reflect and Direct Sensor Mounting, 50
- Pressure
  - Safety instructions, 29

## R

- Reflexor
  - Diagnostic Data, 133
  - Operating Mode and Installation, 124
  - Spectra Graph, 130
  - Zero/Fault Option, 107
- Repair, 139
- Resistive Temperature Device (RTD), 121
  - Ice Bath RTD Calibration, 124
- Return procedures, 140
- ReversaMatic, 75
- RS-232 Serial Port
  - Connections, 188
  - Interface Cable, 189
- RS-232 Setup, 96

## S

- Safety instructions
  - Installation, 29
- Safety notes, 11
- Sensors
  - Forced Transmit and Forced Frequency, 161
  - Identification, 54
  - Installation, Direct Mount, 61
  - Mounting Strap Kits, 52
  - Mounting Supplies, 52
  - Selecting, 56
  - Typical Labels, 55
- Service,
- Set Empty Command, 87
- Site Setup Data Menu, 157
  - HF Diagnostic Menu Item, 158
- Sites
  - Creating a site, 46
  - Save/Rename Site, 50
- SITRANS FUE1010 Transmitter, 21
- Span Data
  - Setting, 98
- Support, 139
- Symbols, 12

## T

- Temperature Sensors
  - Mounting, Clamp-on, Insert (Thermowell), 78
- Test Facilities
  - Command Modes, 149
  - Graphic Screens, 147
  - Hot Key Summary, 156
- Theory of Operation, 23

Totalizer Mode Controls, 95  
Totalizer Modes, 94  
Transmitter Label, 22  
Troubleshooting, 143  
Typical Flowmeter Applications, 23  
Typical Industries Serviced, 23

## **W**

Wall Mounting, 31  
Warning symbols, 12  
Wide Beam Transmission, 27  
Wiring  
    Expanded I/O Module, 171  
    I/O Module, 167  
Wiring Temperature Sensor to Transmitter, 38

## **Z**

Zero Flow Compensation, 74  
ZeroMatic, 75





## Get more information

[www.siemens.com/flow](http://www.siemens.com/flow)

Siemens Industry, Inc.  
Industry Automation Division  
CoC Ultrasonic Flow  
Hauppauge, NY 11788  
USA

Subject to change without prior notice  
Order No.: A5E03086491-AB  
Printed in the USA  
© Siemens AG 01.2013

[www.siemens.com/processautomation](http://www.siemens.com/processautomation)