

# DR4500 Classic: The Benchmark for 12-inch Circular Chart Recorders

*Proven LeaderLine Quality, Accuracy, and Value*

## An Instant Classic

Honeywell's DR4500 Classic circular-chart recorder is ideal for applications in food, pharmaceuticals, environmental testing and metalworking — wherever measured variables must be documented on a single chart and retained to meet industry requirements. Functionality of the Classic can be expanded by adding control capability. Microprocessor-based and field configurable, the Classic is industrially hardened for use in plant and factory.

## Compare — Only the Classic Offers this Unique Line-up of Features

- **Extreme accuracy** — Typically less than  $\pm 1^{\circ}\text{F}$  for the usable thermocouple ranges;  $\pm 0.1\%$  or better for voltage ranges.
- **Universal inputs** — Accepts all thermocouples (Types B, E, J, K, N, R, S, T, W<sub>5</sub>W<sub>26</sub>); Radiamatic; RTDs (100 or 500 Platinum, 100RH); Relative Humidity (0-100%); voltage/current (0-10 mV, 10-50 mV, 0-5V, 0-10V, 4-20 mA); all inputs are keyboard selectable. A built-in 24 Vdc power supply will drive up to 2 transmitters.
- **Easy set-up** — English language prompts and menu selections walk operator through the configuration process. Simplifies set-up and reduces risk of improper configuration.
- **Field configurable** — Chart ranges can be set, and reset, in the field simply by inputting on the keyboard.
- **Standard charts** — Uses a standard 12-inch chart to record process variables; 5,000 preprinted Honeywell charts are available. Whatever your application, we've got the chart.
- **Data brilliantly displayed** — Bright, digital displays are easily read at a distance or in dim light.



## Your Entire Process at a Glance

Selectable displays include indication of PV, SP, deviation, alarms, control mode (automatic or manual), temperature units (F or C), and setpoint ramp (run/hold).

- **Power requirements** — 120/240V, 60 or 50 Hz, 9 watts.

## It's Your Option

Expand the functionality of your DR4500 Classic recorder with these options:

- **Control** — 2 loops are available, configurable for On/Off, PID-A, PID-B, or PD with manual reset. Control outputs of Time, Current or Position Proportioning,

Simplex or Duplex with Mixed Output forms, fully field selectable to provide the utmost versatility.

- **Alarms** — Fully configurable alarms alert you to critical process changes.
- **Door lock**
- **Flow totalization**
- **Chart illumination**
- **Heavy duty door**
- **Auxiliary 4-20 mA output**
- **UL listing**
- **CSA/FM approved**
- **CE Mark**

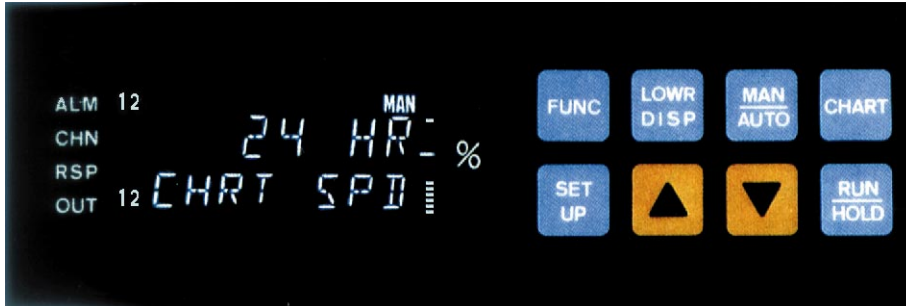

Brilliant fluorescent displays and English language prompts not only simplify configuration but also keep you informed of process conditions at all times. Display shown indicates recorder is configured for a chart speed of 24 hours; operation is manual.

## A Complete Product Offering

The DR4500 Classic is a member of Honeywell's broad line of digital instrumentation. If the DR4500 Classic doesn't meet your recording needs, Honeywell has the digital recorder that does. Talk to your Honeywell distributor or sales representative for price and delivery information on the DR4500 Classic and other Honeywell digital recorders.

If it's worth recording, it's worth specifying Honeywell.

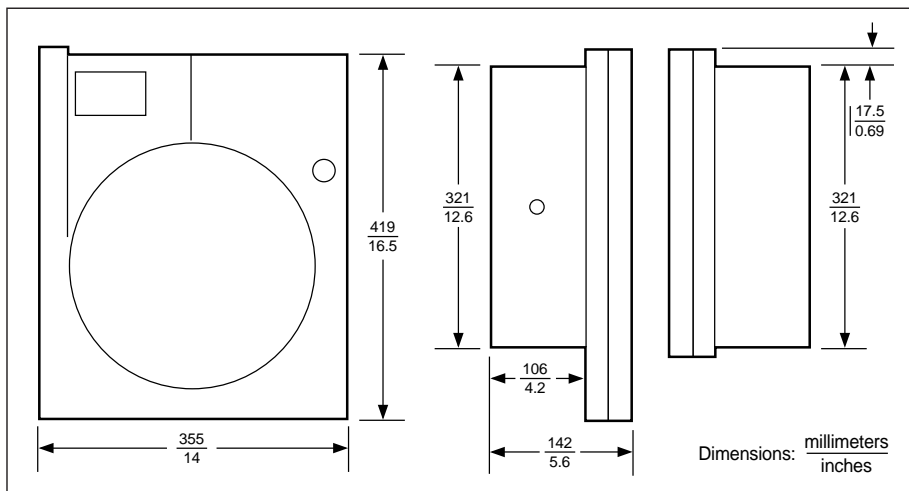

**Honeywell**

### Sensing and Control

Honeywell Inc.  
11 West Spring Street  
Freeport, IL 61032  
1-800-343-0228



44-45-58-03 Rev. (1M) 12/00

[www.honeywell.com/sensing](http://www.honeywell.com/sensing)