



TX200H™ HART® Pressure Transmitter



Installation and Maintenance Instructions

Please read all instructional literature carefully and thoroughly before starting. Refer to the final page for the listing of Recommended Practices, Liabilities and Warranties.

GENERAL

The TX200H is a registered HART 7 compliant device. It is a highly accurate, rugged, SMART pressure transmitter that can communicate digitally and via the 4-20 mA analog signal output. The TX200H utilizes the HART protocol and an internal microcontroller to allow the end-user to easily configure and calibrate the pressure transmitter as it provides process variable measurement and device health data.

HART is an acronym for Highway Addressable Remote Transducer and it has become the most widely adopted standard for industrial communication. The Hart protocol is based on a standardized set of commands that is maintained by the HART Communication Foundation (HCF) and allows any end-user to easily integrate devices like the TX200H into their HART enabled system. The TX200H, as a registered HART device has been designed to communicate with other HART enabled devices such as a software package running on a PC with HART interface or a field portable HART communicator.

 BEFORE INSTALLING, CHECK THE SENSOR MODEL SELECTED FOR COMPATIBILITY TO THE PROCESS MEDIA IN CONTACT WITH THE SENSOR AND WETTED PARTS.

 MISUSE OF THIS PRODUCT MAY CAUSE EXPLOSION AND PERSONAL INJURY. THESE INSTRUCTIONS MUST BE THOROUGHLY READ AND UNDERSTOOD BEFORE UNIT IS INSTALLED.

 **UL** THIS EQUIPMENT IS SUITABLE FOR USE IN CLASS I, DIVISION 1, GROUPS A, B, C AND D; CLASS II, DIVISION 1, GROUPS E, F AND G; CLASS III; OR NON-HAZARDOUS LOCATIONS ONLY. -40°C (-40°F) \leq TAMB. $\leq +85^{\circ}\text{C}$ ($+185^{\circ}\text{F}$), ENCLOSURE TYPE 4X.

 THIS EQUIPMENT IS ATEX CERTIFIED FOR EQUIPMENT CATEGORY 2. SUITABLE FOR APPROPRIATE USE IN GAS ZONE 1 AND DUST ZONE 21 APPLICATIONS.

EN 60079-0:2012, EN 60079-1:2007, EN 60079-31:2009

 0539 DEMKO 08 ATEX 0810742X

 II 2 G Ex d IIC T5 Gb

 II 2 D Ex tb IIIC T90°C Db

IP66

$-40^{\circ}\text{C} \leq \text{Tamb.} \leq +80^{\circ}\text{C}$

UE declarations and third-party issued Agency certifications are available for download at www.ueonline.com/prod_approval.

 PROOF PRESSURE* LIMITS STATED IN THE LITERATURE AND ON THE TRANSMITTER HOUSING MUST NEVER BE EXCEEDED, EVEN BY SURGES IN THE SYSTEM. OCCASIONAL OPERATION OF UNIT

HART® is a registered trademark of the Hart Communication Foundation

UP TO MAXIMUM PRESSURE IS ACCEPTABLE (E.G. START-UP, TESTING). CONTINUOUS OPERATION SHOULD NOT EXCEED THE DESIGNATED OVER RANGE PRESSURE**.

*Proof Pressure

The maximum pressure to which a pressure sensor may be occasionally subjected, which causes no permanent damage (e.g., start-up, testing).

**Over Range Pressure

The pressure value to which a transmitter may be continuously subjected, without causing a shift in calibration or damage to the sensor.



THESE PRODUCTS DO NOT HAVE ANY FIELD REPLACEABLE PARTS. ANY SUBSTITUTION OF COMPONENTS MAY IMPAIR UNIT SAFETY AND SUITABILITY FOR CLASS I, DIVISION 1.



THE EPOXY RESIN SHALL NOT BE SUBJECTED TO A TEMPERATURE GREATER THAN 125°C.

Please refer to product bulletin for product specifications. Product bulletin may be found at www.ueonline.com

Date code format on nameplate is "YYWW" for year and week.

Part I - Installation

Tools Needed

Adjustable Wrench

MOUNTING



ALWAYS LOCATE UNITS WHERE SHOCK, VIBRATION AND AMBIENT TEMPERATURE FLUCTUATIONS ARE MINIMAL. DO NOT MOUNT IN AMBIENT TEMPERATURE AREAS EXCEEDING 185°F / 85°C (IF UL/cUL APPROVAL IS APPLICABLE) OR 176°F / 80°C (IF ATEX APPROVAL IS APPLICABLE).



IF SEVERE PRESSURE SURGES ARE EXPECTED, CONSIDER THE USE OF A PRESSURE SNUBBER.



UNIT MAY BE MOUNTED IN ANY POSITION. ALWAYS HOLD A WRENCH ON THE SENSOR FLATS (PRESSURE PORT) WHEN MOUNTING UNIT.

Panel Mounting via 1/2" NPTM or M20 Electrical Connection

When panel mounting, mount through 7/8" clearance hole in panel. Hold in place with serrated 1/2" or M20 conduit nut. Always support the unit by holding a wrench on the hex fitting and not the housing body.

WIRING

No special or separate wiring is required for digital communication with HART devices since the HART FSK (Frequency Shift Keying) signal is superimposed on top of the 4-20 mA output signal. Digital data is sent to and from the field device via a HART master while real-time process information is available via the 4-20 mA signal. It is recommended that a high quality twisted pair or shielded wire cable be used where extended lengths are required or electrical noise may be present.

NOTE: The TX200H is reverse bias protected so no damage will result in the event of accidental reversal of power leads.

 DISCONNECT ALL SUPPLY CIRCUITS BEFORE WIRING UNIT. ELECTRICAL RATINGS STATED IN LITERATURE AND ON THE TRANSMITTER MUST NOT BE EXCEEDED.

 WIRE IN ACCORDANCE WITH LOCAL AND NATIONAL ELECTRICAL CODES. THROUGH PROPER INSTALLATION, THE WIRES SHALL BE PROTECTED AGAINST MECHANICAL DAMAGE, I.E. BY USE OF A CONDUIT.

 THE TX200H TRANSMITTER ACCEPTS A SUPPLY VOLTAGE OF 10-36 VDC AND SHALL NOT EXCEED 36 VDC. THE SUPPLY VOLTAGE MUST BE ISOLATED FROM MAINS VOLTAGE BY DOUBLE/REINFORCED INSULATION.

 EARTH GROUND MUST ALWAYS BE CONNECTED TO THE GREEN WIRE TO PROVIDE SHIELDING AND ELECTRICAL SAFETY.

 THE TX200H WIRING MUST BE INSTALLED IN A GROUNDED METAL CONDUIT OR WITH OTHER SUITABLE SHIELDING IN ORDER TO MEET EUROPEAN EMC DIRECTIVE REQUIREMENTS.

ATEX REQUIREMENTS ONLY

 THE WIRING TO THE PRESSURE SENSOR MUST ONLY BE CONNECTED IN THE SAFE AREA OR BY AN APPROVED TERMINAL BOX CERTIFIED TO EN 60079-0:2012, EN 60079-1:2007, EN 60079-31:2009 FOR HAZARDOUS LOCATIONS.

 EXTERNAL GROUNDING SCREW (OPTION M460) IS REQUIRED FOR NON-METALLIC CONDUIT SYSTEMS (SEE FIGURE 1).

A 1/2" NPT (male) or M20 conduit connection is provided on the top of the transmitter with 18 AWG, 72" length lead-wires. An external grounding screw and clamp is provided when selecting option M460 (see figure 1). The lead-wires are color coded as follows:

Red: + signal
Black: - signal
Green: Earth ground

OPTION M460 EXTERNAL GROUNDING SCREW

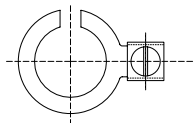

Figure 1

Bench Operation:

To operate the TX200H on the bench, it must be connected to a power supply and a load resistor (see Figure 2). The HART master (e.g., handheld communicator) may also be connected directly across the red and black wires at the TX200H. A voltmeter across the 250 Ω resistor can be used to measure the current in the loop ($I_{loop} = V_{resistor} / 250$). At 4mA the voltmeter will read 1 volt and at 20 mA the meter will read 5 volts.

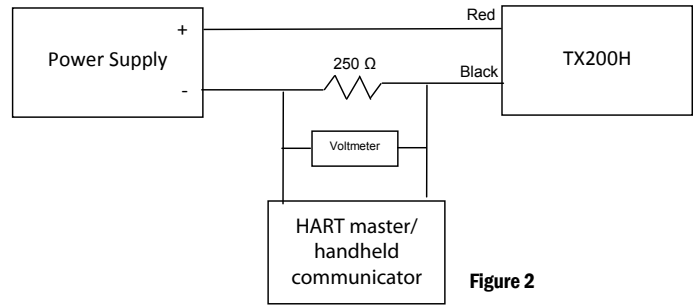

Figure 2

Field Operation:

The TX200H can be connected to any HART compatible input card or module or any standard 4-20mA input if the HART interface is not being used. In most cases the power supply and the load resistor are built into the input card or module (see Figure 3).

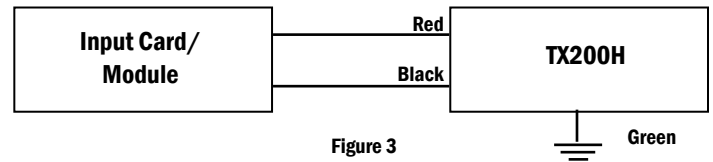

Figure 3

Power Supply/Load Limits:

For general operation of the TX200H while using HART the series loop resistance should be between 230 to 600 ohms and the power supply voltage should be 24V nominal.

The TX200H can be operated without the HART interface within the operating limits of the power supply and loop resistance as shown in Figure 4.

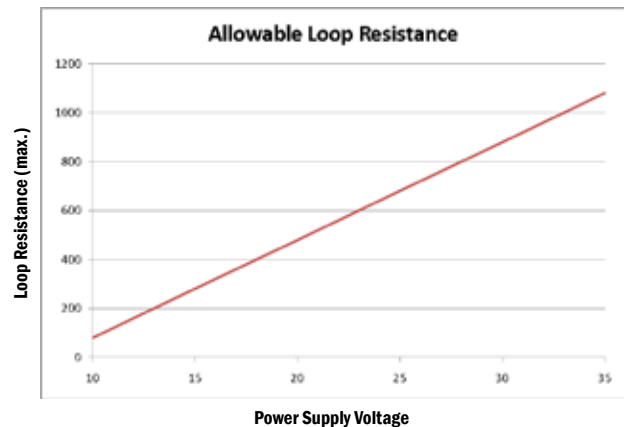

Figure 4

Fault Currents:

Under normal operating conditions the analog output signal of the TX200H will remain between 4-20mA. In the event that the pressure goes beyond the operating range of the device or in a fault condition, the TX200H will indicate the condition on the 4-20mA loop as follows:

Loop Current	Description
3.7 mA	Check Sum Error
3.9 mA	Low Limit of Output Range
22.0 mA	Upper Limit of Output Range
24 mA	Fault Current

Part II - Set-Up

Tools Needed

HART Communicator or other Master

Using a HART handheld communicator, or other HART master, you can access the many features of the TX200H.

Read Device Information: you can read information such as the model number and revision, the device I.D. and the range of the sensor.

Device Setup: can be used to setup or commission a device prior to placing it in service. These features allow the user to write things like a device tag and a device description into the TX200H so that it can be uniquely identified over the HART interface.

Basic/Detailed Setup Features Include:

1. **Device Tag:** The device tag identifies where the device will be placed into service. A replacement device can be programmed to have the same tag as the device it is replacing prior to installation.
2. **Process Variable Units:** Allows the user to select the units of measure (e.g., "wc, "Hg, psi, mbar, bar, kg/cm², kPa, MPa).
3. **Process Variable Limits:** Allows the user to read the upper and lower sensor limits and to read and adjust the upper and lower range of the TX200H within the sensors limits and the allowable turn-down range.
4. **Device Description/Message:** The user can program a text field that reflects the function of the device.
5. **Damping:** The user can adjust the level of the damping applied to the process variable. This feature is used to reduce the effect of fluctuations in the readings. The value entered is the time constant of the software filter, which adjusts the amount of damping.

Process Variables: can be read over the HART interface. Pressure is the primary variable. Temperature is the secondary variable. **NOTE:** Reported temperature is the ambient temperature at the back of the sensor and not the process media temperature.

- **Primary Variable:** can be read in pressure units, percent of range or in mA.
- **Secondary Variable:** Available in °F

Diagnostic and Service: there are several TX200H diagnostic and service features available over the HART interface.

1. **Calibration:** There are two ways to calibrate the TX200H.
 - a. If a calibrated pressure source is available, the user can apply a low and high pressure and set the low and high range points.
 - b. If no pressure source is available, the user can manually enter values for the upper range limit and the lower range limit.
2. **D/A Trim:** This feature allows the user to calibrate the D/A converter that generates the 4-20mA signal. The output is first set to 4mA. The user must measure and enter the loop current. The output is then set to 20mA. The user again must measure and enter the loop current. The output of the D/A is adjusted for offset and span.
3. **Loop Test:** The loop test feature forces the output current to a user specified value. It can be set to 4mA, 20mA or to another value entered by the user.

Re-Ranging: Using the HART interface, the range of the TX200H can be modified. This is useful in situations where the exact range transmitter is not available. Re-Ranging is accomplished by changing the lower range value and the upper range value to achieve the desired range. There are limitations on the range adjustment. The lower/upper range limits must be within the upper and lower sensor range (as marked on the transmitter body and within the certificate of calibration) and the span must be greater than the process variable (PV) minimum span programmed in the device. The PV min. span is 10% of the range of the device for models with a pressure range of ≥ 100 psi and 20% of the range of the device for models with a pressure range < 100 psi.

For example, a 1000 psi transmitter can be re-ranged to be a 100 psi transmitter.

Multi-Drop Mode: Using HART communication it is possible to connect up to 15 field devices to a HART master over a single pair of wires. In this topology (see Figure 5) the field device is placed in a fixed current mode and all communication occurs over the HART interface. Each device is assigned a unique poll address (1-15). This serves as a unique address so that the master can access the field devices individually. **NOTE:** The TX200H ships from UE with the poll address set to 0. A poll address of 0 indicates the device is not in multi-drop mode.

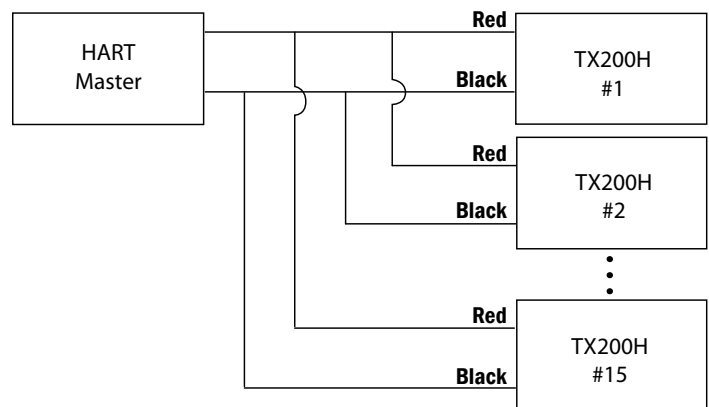

Figure 5

Zone Hazardous Locations Flameproof Gap and Joint Details

Electrical conduit fitting threaded connection: M20 x 1.5, 7 threads minimum engagement.

Part III - Dimensions

Dimensional drawings for all models may be found at www.ueonline.com

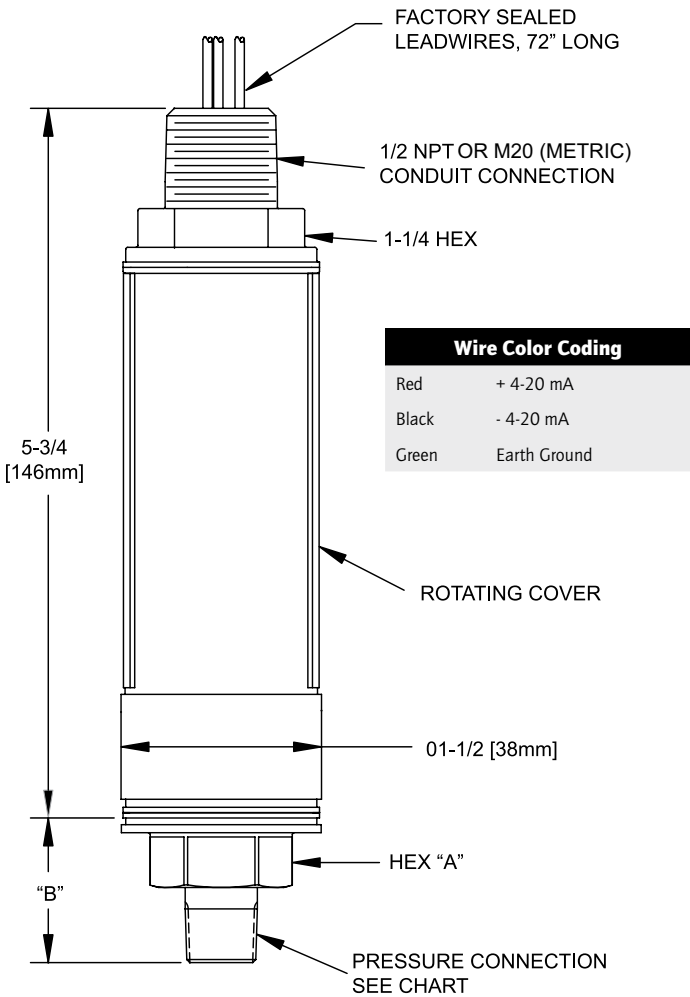

Wire Color Coding	
Red	+ 4-20 mA
Black	- 4-20 mA
Green	Earth Ground

Pressure Connection Chart

Code	Description	Hex "A" in	Length "B" in [mm]
1	1/4" NPT (female)	15/16	0.54 [13.7]
2	1/2" NPT (female)	1-3/8	1.01 [25.7]
3	1/2" NPT (male)	15/16	1.26 [32.0]
4	HF4 Autoclave (female)	15/16	0.54 [13.7]
5	FH6 Autoclave (female)	1-3/8	0.90 [22.9]
6	LF4 Autoclave (female)	15/16	0.54 [13.7]
7	LF6 Autoclave (female)	15/16	0.65 [16.5]
8	1/4" NPT (male)	15/16	0.97 [24.6]
9	7/16-20 SAE (female)	15/16	0.54 [13.7]
A	G-1/4 (female)	15/16	0.54 [13.7]
B	G-1/2 (female)	1-3/8	1.01 [25.7]
C	7/16-20 SAE (male)	15/16	0.77 [19.6]
D	HM4 Autoclave (male)	15/16	1.10 [27.9]
E	HM6 Autoclave (male)	15/16	1.29 [32.8]
F	LM4 Autoclave (male)	15/16	1.18 [30.0]
G	LM6 Autoclave (male)	15/16	1.32 [33.5]
H	G-1/4 (male)	15/16	1.03 [26.2]
J	G-1/2 (male)	1-3/8	1.78 [45.2]

Pressure Ranges

Code	Range
03	= 0 to 15 psis
04	= 0 to 30 psis
05	= 0 to 50 psis
06	= 0 to 100 psis
07	= 0 to 250 psis
08	= 0 to 500 psis
09	= 0 to 1000 psis
17	= 0 to 1500 psis
18	= 0 to 2000 psis
10	= 0 to 2500 psis
19	= 0 to 3000 psis
11	= 0 to 5000 psis
20	= 0 to 6000 psis
12	= 0 to 7500 psis
13	= 0 to 10,000 psis
14	= 0 to 15,000 psis
15	= 0 to 20,000 psis
16	= 0 to 25,000 psis

Option M423 & M513 Junction Boxes

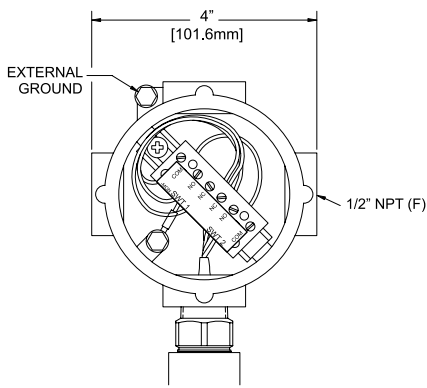

M423
ATEX flameproof compliant junction box
(Not UL or cUL approved)

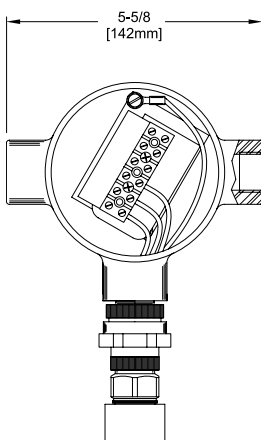

M513
UL/CSA approved, explosion proof junction box
(Meets enclosure type 4 requirements only. Not ATEX compliant)

Part IV - TX200H HART COMMANDS

Command Number	Universal Commands, Command Function
0	Read Unique Identifier Distributor, model, device id, tag, date, ID code, device type code (E18D) sw rev, device id,
1	Read Primary Variable
2	Read Loop Current and Percentage of Range
3	Read Current and up to Four Dynamic Variables
6	Write Polling Address
7	Read Loop Configuration
8	Read Dynamic Variable Families
9	Read up to Four Device Variables with Status
11	Read Unique Identifier Associated with Tag
12	Read Message
13	Read Tag, Descriptor, Date
14	Read Primary Variable Transducer Information
15	Read Device Information
16	Read Final Assembly Number
17	Write Message
18	Write Tag, Descriptor, Date
19	Write Final Assembly Number
20	Read Long Tag
21	Read Unique Identifier Associated with Long Tag
22	Write Long Tag
38	Reset Configuration Changed Flag
48	Read Additional Device Status
Command Number	Common-Practice Commands, Command Function
33	Read Device Variables
34	Write Primary Variable Damping Value
35	Write Primary Variable Range Values
36	Set Primary Variable Upper Range Value
37	Set Primary Variable Lower Range Value
40	Enter/Exit Fixed Current Mode
42	Perform Master Reset
43	Set Primary Variable (Trim) Zero
44	Write Primary Variable Units
45	Trim Loop Current Zero
46	Trim Loop Current Gain
47	Write Primary Variable Transfer Function
54	Read Device Variable Information
59	Write Number of Responses Preambles
71	Lock Device (Allows a Master to temporarily or permanently lock the device)
76	Read lock status

Response Codes	
Code	Description
0	Success
2	Invalid Selection
3	Passed Parameter Too Large
4	Passed Parameter Too Small
5	Too Few Data Bytes Received
6	Error (Device Specific Command Error)
7	In Write Protect Mode
8	Multi-Definition Warning
	Update Failure
	Set to Nearest Possible Value
	All but running delayed responses flushed
9	Multi-Definition Error
	Lower Range Value too High
	Applied Process too High
	Not in Proper Current Mode
10	Multi-Definition Error
	Lower Range Value too Low
	Applied Process too Low
	Invalid Local Panel Code
11	Multi-Definition Error
	Upper Range Value too High
	In Multi-Drop Mode
	Invalid Device Variable Code
	Trim Error Excess Correction Attempted
	Cannot Lock Panel
12	Multi-Definition Error
	Upper Range Value too Low
	Invalid Units Code
13	Multi-Definition Error
	Both Upper and Lower Range Values Out of Limits
14	Multi-Definition Error
	Span too Small
	New Lower Range Value Pushed Upper Range Value Over Limit
16	Multi-Definition Error
	Invalid Analog Channel Number
	Access Restricted
17	Invalid Device Variable Index
18	Invalid Units Code
19	Device Variable Index Not Allowed
20	Invalid Extended Command Number
28	Invalid Range Units Code
30	Command Response Truncated
32	Busy
33	Delayed Response Initiated
34	Delayed Response Running
35	Delayed Response Dead
36	Delayed Response Conflict
64	Command Not Implemented

RECOMMENDED PRACTICES AND WARNINGS

United Electric Controls Company recommends careful consideration of the following factors when specifying and installing UE pressure and temperature units. Before installing a unit, the Installation and Maintenance instructions provided with unit must be read and understood.

- To avoid damaging unit, proof pressure and maximum temperature limits stated in literature and on nameplates must never be exceeded, even by surges in the system. Operation of the unit up to maximum pressure or temperature is acceptable on a limited basis (e.g., start-up, testing) but continuous operation must be restricted to the designated adjustable range. Excessive cycling at maximum pressure or temperature limits could reduce sensor life.
- A back-up unit is necessary for applications where damage to a primary unit could endanger life, limb or property. A high or low limit switch is necessary for applications where a dangerous runaway condition could result.
- The adjustable range must be selected so that incorrect, inadvertent or malicious setting at any range point cannot result in an unsafe system condition.
- Install unit where shock, vibration and ambient temperature fluctuations will not damage unit or affect operation. When applicable, orient unit so that moisture does not enter the enclosure via the electrical connection. When appropriate, this entry point should be sealed to prevent moisture entry.
- Unit must not be altered or modified after shipment. Consult UE if modification is necessary.
- Monitor operation to observe warning signs of possible damage to unit, such as drift in set point or faulty display. Check unit immediately.
- Preventative maintenance and periodic testing is necessary for critical applications where damage could endanger property or personnel.
- Electrical ratings stated in literature and on nameplate must not be exceeded. Overload on a switch can cause damage, even on the first cycle. Wire unit according to local and national electrical codes, using wire size recommended in installation sheet.
- Do not mount unit in ambient temp. exceeding published limits.

LIMITED WARRANTY

Seller warrants that the product hereby purchased is, upon delivery, free from defects in material and workmanship and that any such product which is found to be defective in such workmanship or material will be repaired or replaced by Seller (Ex-works, Factory, Watertown, Massachusetts. INCOTERMS); provided, however, that this warranty applies only to equipment found to be so defective within a period of 36 months from the date of manufacture by the Seller. Seller shall not be obligated under this warranty for alleged defects which examination discloses are due to tampering, misuse, neglect, improper storage, and in any case where products are disassembled by anyone other than authorized Seller's representatives. EXCEPT FOR THE LIMITED WARRANTY OF REPAIR AND REPLACEMENT STATED ABOVE, SELLER DISCLAIMS ALL WARRANTIES WHATSOEVER WITH RESPECT TO THE PRODUCT, INCLUDING ALL IMPLIED WARRANTIES OF MERCHANTABILITY OR FITNESS FOR ANY PARTICULAR PURPOSE.

LIMITATION OF SELLER'S LIABILITY

SELLER'S LIABILITY TO BUYER FOR ANY LOSS OR CLAIM, INCLUDING LIABILITY INCURRED IN CONNECTION WITH (I) BREACH OF ANY WARRANTY WHATSOEVER, EXPRESSED OR IMPLIED, (II) A BREACH OF CONTRACT, (III) A NEGLIGENT ACT OR ACTS (OR NEGLIGENT FAILURE TO ACT) COMMITTED BY SELLER, OR (IV) AN ACT FOR WHICH STRICT LIABILITY WILL BE INPUTTED TO SELLER, IS LIMITED TO THE "LIMITED WARRANTY" OF REPAIR AND/OR REPLACEMENT AS SO STATED IN OUR WARRANTY OF PRODUCT. IN NO EVENT SHALL THE SELLER BE LIABLE FOR ANY SPECIAL, INDIRECT, CONSEQUENTIAL OR OTHER DAMAGES OF A LIKE GENERAL NATURE, INCLUDING, WITHOUT LIMITATION, LOSS OF PROFITS OR PRODUCTION, OR LOSS OR EXPENSES OF ANY NATURE INCURRED BY THE BUYER OR ANY THIRD PARTY.

UE specifications subject to change without notice.



UNITED ELECTRIC
CONTROLS

180 Dexter Avenue, P.O. Box 9143
Watertown, MA 02471-9143 USA
Telephone: 617 926-1000 Fax: 617 926-2568
<http://www.ueonline.com>