

Design Features and Operating Concepts

Valves with electro-mechanical actuators for quick opening or closing action

Normally closed shut-off valves are used in burner system fuel supply lines on industrial boilers, furnaces, ovens, kilns, and other heating processes. All valves are designed to shut-off fuel automatically and instantly with any interruption in the electric power supplied through your safety circuit.

These valves are also used for the **manual** or **motorized** opening or closing of pipe lines carrying gases and liquids commonly used in industrial processes. Normally closed valves cannot be opened until the interlocking safety control circuit is proven and resulting electrical power is supplied to the shut-off valve.

Motorized automatic valve actuators are used where remote access or unmanned applications are needed.

NOTE: Valve motors are protected against thermal overload. Normal duty cycles of 1 cycle per minute or less should allow motor thermal overload to sufficiently cool between cycles. If the normal valve duty cycle is exceeded, the motor must be allowed to cool before the thermal protection will automatically reset.

Manual reset actuators require operating personnel to be physically present to actuate the valve from its at rest position.

Normally open vent valves are most often used as the bleed valve in a block-and-bleed pipe train, sometimes required by insurance authorities. They are designed to open a vent line automatically and instantly upon any interruption in the electric power supply through your safety control circuit.

These normally open valves are also used in protective atmosphere systems and other gaseous and fluid service requiring quick opening or by-pass purging action.

Like the normally closed versions, both automatic and manual reset actuators are available for remote access locations, or when operating personnel's physical presence is preferred.

All Maxon valves feature one-piece cast iron or cast steel bodies with micro-lapped seats and discs. Straight through flow path minimizes pressure drop through full open swinging gate or rising stem (guillotine action) bodies.

Valve Body Design Details

To provide seals in your process service lines, Maxon uses two different styles of valve bodies:

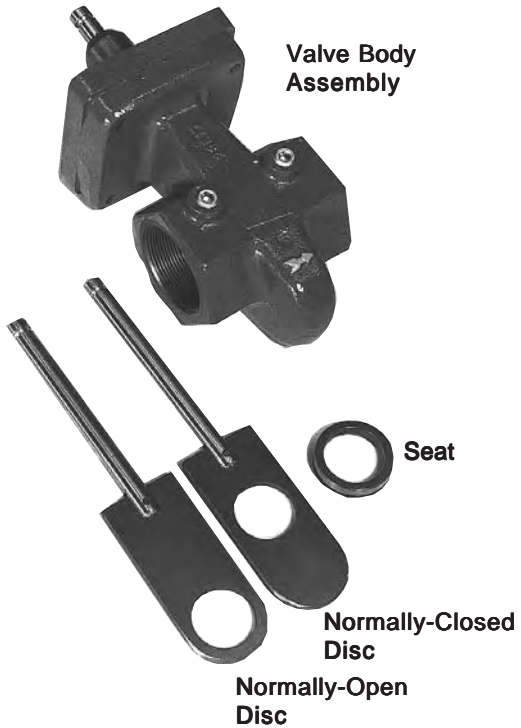

Rising stem (guillotine action) bodies are frequently used in normally closed and normally open gas valves. The micro-lapped, spring loaded guillotine disc gets a pressure assist from the flowing gases to seal against the downstream micro-lapped metal seat ring. The carefully machined seal surfaces and extremely close tolerances of the valve body operating mechanism promote positive closing action. Frequent cycling action constantly shears accumulated dirt or residue from the disc and seat to insure instantaneous and reliable sealing.

The location of the port in the disc is the basic difference between normally open and normally closed valve bodies. Both valves function by the top assembly mechanism driving the stem and disc down into the valve body, opening (or closing) the flow path. Both valves trip to their rest position when their top assembly's compression spring is released to pull the stem and connected disc up out of the body.

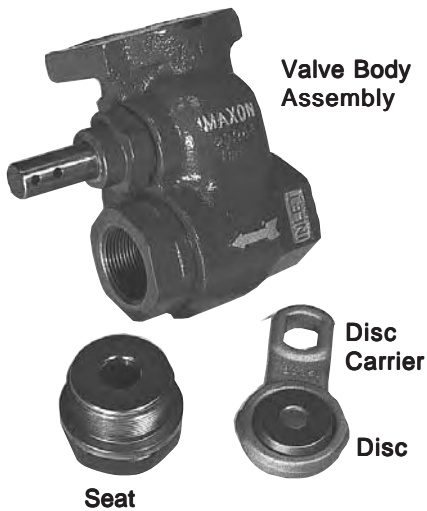

Swinging gate bodies are frequently used in normally closed oil valves and for some non-combustible gas applications. This design provides the same seal capabilities, but in a slightly different operating mode. The hard faced micro-lapped seat nut is threaded into the one-piece valve body. The free-floating, hard faced, spring loaded circular disc swings across the seat. Line pressure also assists in sealing the disc to the downstream seat.

Here again, frequent use and cycling actually helps to keep your valve clean. Since the free-floating disc is swinging across the circular seat nut on the arc created by the disc carrier, the disc rotates slightly on every cycle. This provides a fresh, clean surface area for sealing off the flow lines.

Maxon valve bodies have special service trim options available to meet your particular fluid service requirements. Contact your Maxon representative for details.

Valve Body Capacities/Specifications

Table 1: Normally closed valve bodies

Body Material	End Connections	Pipe Size (in inches)	Cv Factor	Body Type [1]	
Gray Iron	Threaded	.375 & .5	3.4	SG	
			9.6	SG	
		.75	20	RS	
			12	SG	
		1	20	RS	
			17	SG	
		1.25	45	RS	
			53	RS	
		2	86	RS	
		2.5	127	RS	
			304	RS	
		3	173	RS	
	423		RS		
	Flanged	2	86	RS	
			127	RS	
		2.5	304	RS	
			423	RS	
		3	423	RS	
4		490	RS		
	719	RS			
6	869	RS			
	1172	RS			
Cast Steel or Stainless Steel	Threaded	.5	3.4	SG	
			9.6	SG	
		1	12	SG	
			20	RS	
		1.25	17	SG	
			45	SG	
		1.5	53	RS	
		2	86	RS	
		Flanged	2.5	304	RS
				423	RS
			4	490	RS
				719	RS
	6		869	RS	
			1172	RS	

[1] RS = Rising Stem valve body
SG = Swinging Gate valve body

See catalog pages 6117-6119 for construction details.

NOTE: Typically, pressure drop for gas flows should not exceed 10% of inlet pressure; however, for 2" and smaller valves, the drop should not exceed 5 PSIG, and for 2.5" and larger valves, must not exceed 2.5 PSIG.

Select valve size on basis of the **lower** of these parameters to avoid critical flow conditions.

Table 2: Normally open valve bodies

Body Material	End Connections	Pipe Size (in inches)	Cv Factor	Body Type [1]
Gray Iron	Threaded	.75	20	RS
		1	20	RS
		1.5	53	RS
		2	86	RS
		2.5	304	RS
		3	423	RS
	Flanged	2	86	RS
		2.5	304	RS
		3	423	RS
		4	490	RS
Cast Steel	Threaded	1	20	RS
		1.5	53	RS
		2	86	RS
	Flanged	2.5	304	RS
		3	423	RS
		4	490	RS

Each complete valve assembly must include one of these valve bodies, regardless of ultimate series designation.

Flows through the valve body and resulting pressure drops may be estimated by inserting your specific conditions into the following formula and using C_v flow factors given for each valve body.

$$\text{Gases: } Q = (1360) \times (C_v) \times \left(\sqrt{\frac{(P_1 + P_2)}{G T_f}} \right) \times \left(\sqrt{\frac{(P_1 - P_2)}{2}} \right)$$

$$\text{Liquids: } V = (C_v) \times \left(\sqrt{\frac{(P_1 - P_2)}{G_f}} \right)$$

Where:

- G = Gas specific gravity (air = 1.0)
- G_f = Specific gravity @ flowing temperature °F
- P₁ = Inlet pressure PSIA (14.7 psi + psi gauge)
- P₂ = Outlet pressure PSIA (14.7 psi + psi gauge)
- Q = Cubic feet per hour @ 14.7 PSIA and 60°F
- T_f = Flowing temperature absolute (460° + °F)
- V = Flow in U.S. gallons/minute of water

Valve Body Capacities with Natural Gas at 5 inches w.c. Inlet Pressure

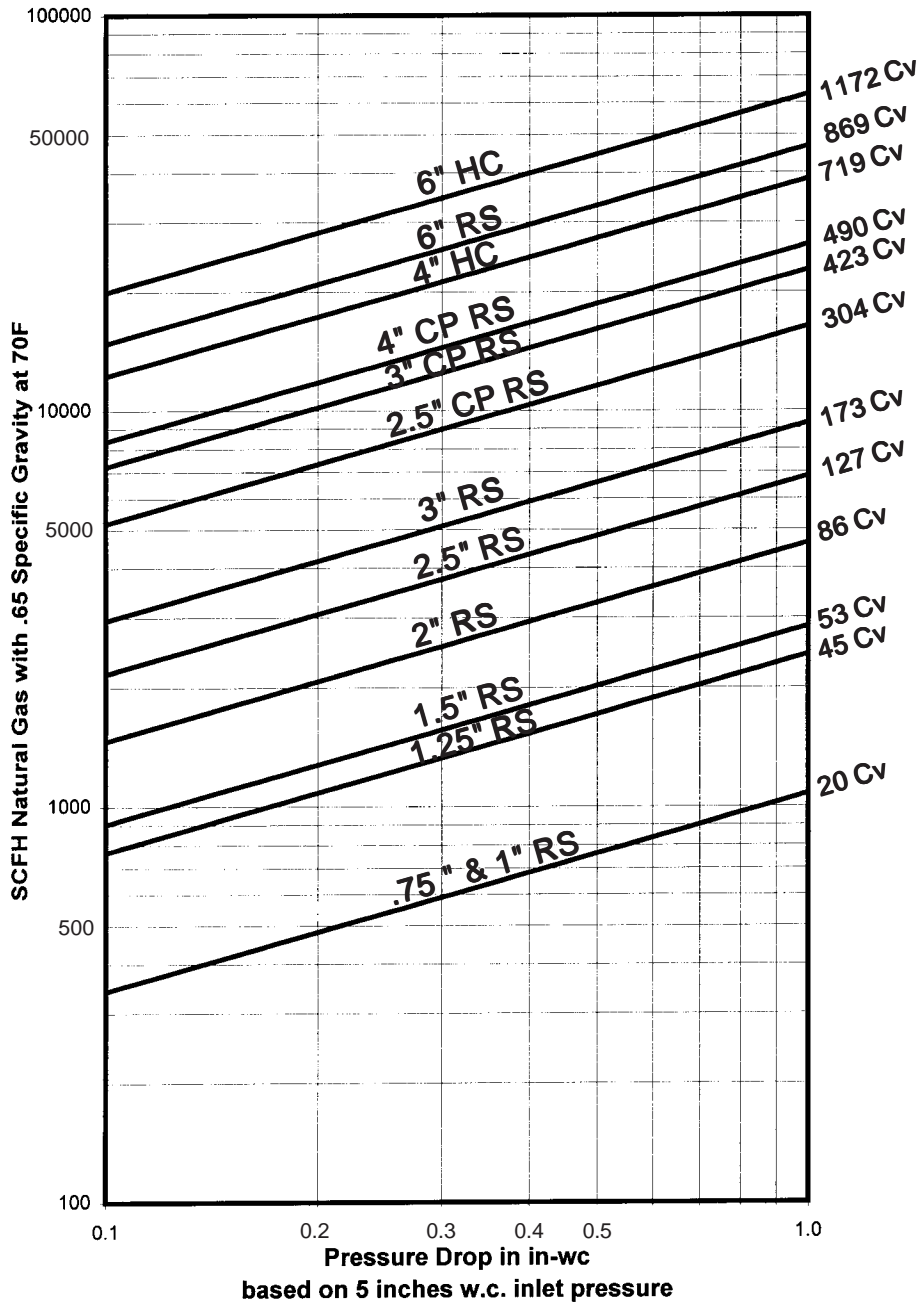

Approximate pressure drops for various valve sizes and flows may be determined by using this graph.

Typically, pressure drop for fuel flows should not exceed 10% of inlet pressure.

Select valve size on basis of the **lower** of these parameters to avoid critical flow conditions.

Valve Body Capacities with Natural Gas at 1 PSIG Inlet Pressure

Approximate pressure drops for various valve sizes and flows may be determined by using this graph.

Typically, pressure drop for fuel flows should not exceed 10% of inlet pressure.

Select valve size on basis of the **lower** of these parameters to avoid critical flow conditions.

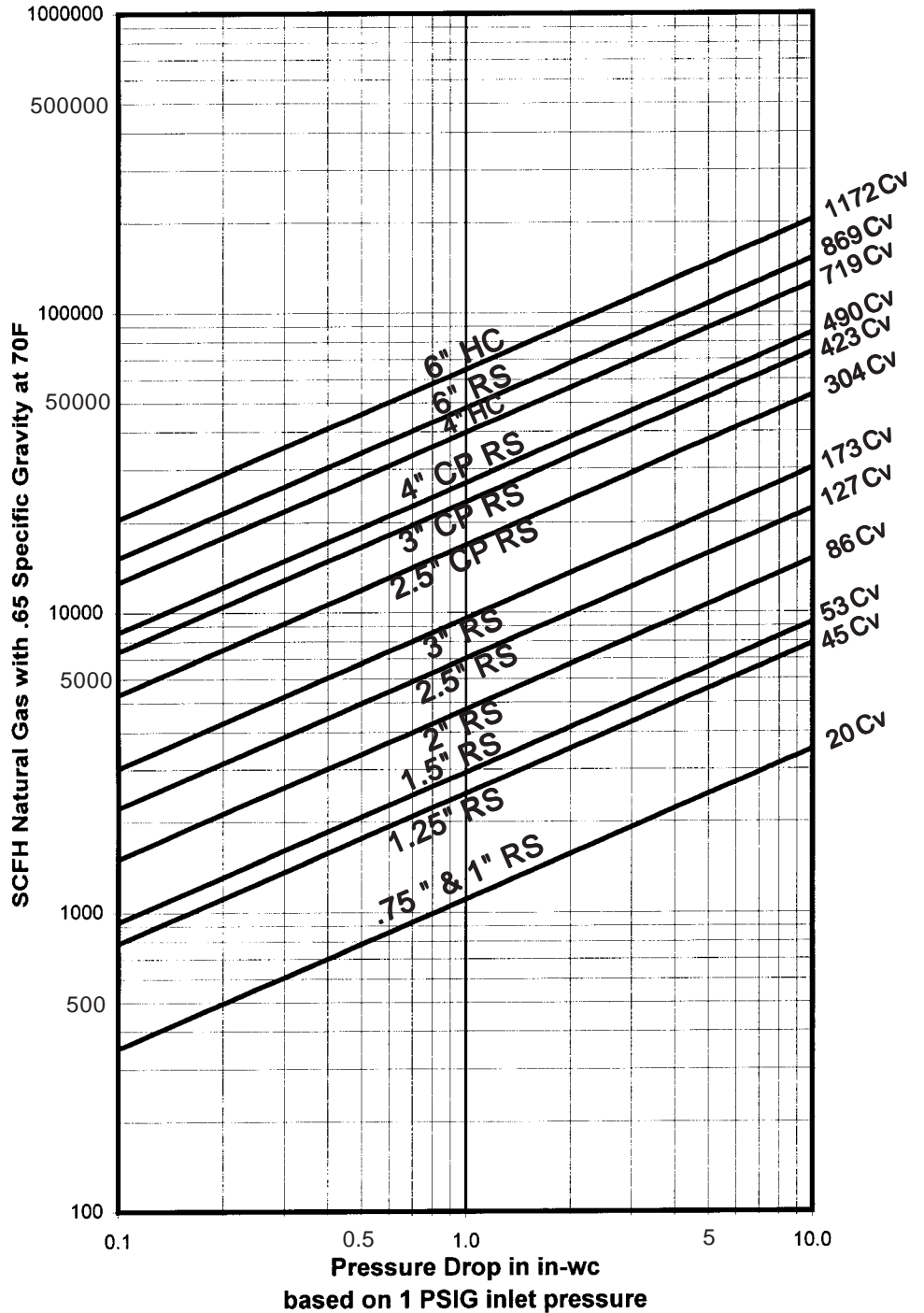

Valve Body Capacities with Natural Gas at 5 PSIG Inlet Pressure

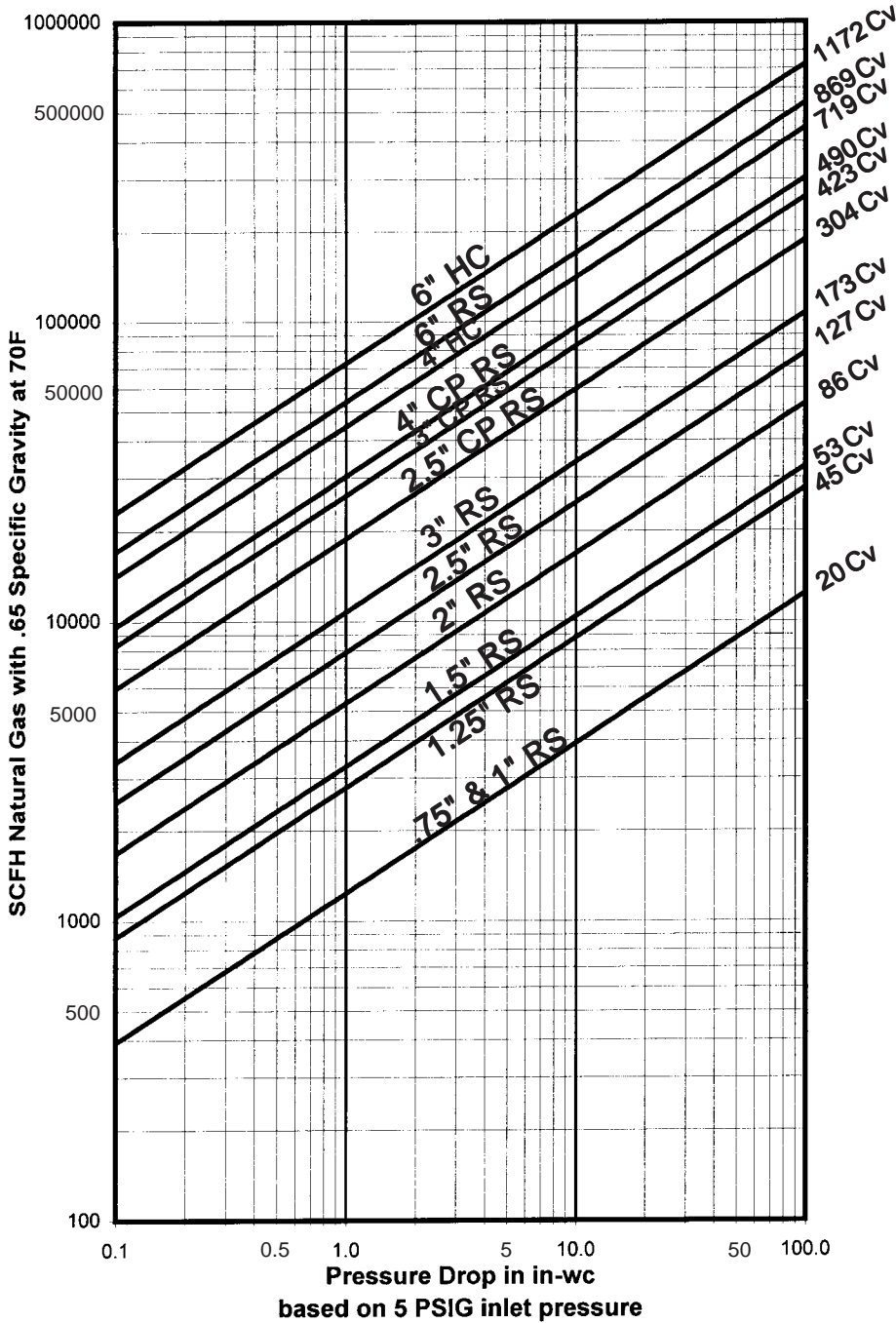

Approximate pressure drops for various valve sizes and flows may be determined by using this graph.

Typically, pressure drop for fuel flows should not exceed 10% of inlet pressure; however, for 2" and smaller valves, the drop should not exceed 5 PSIG, and for 2-1/2" and larger size valves, must not exceed 2.5 PSIG.

Select valve size on basis of the **lower** of these parameters to avoid critical flow conditions.

Valve Body Capacities with #2 Oil

To select a valve for YOUR application, use either C_v factor calculations, or this graph showing approximate pressure drop at various flows of #2 oil.

Typically, pressure drop for fuel flows should not exceed 10% of inlet pressure.

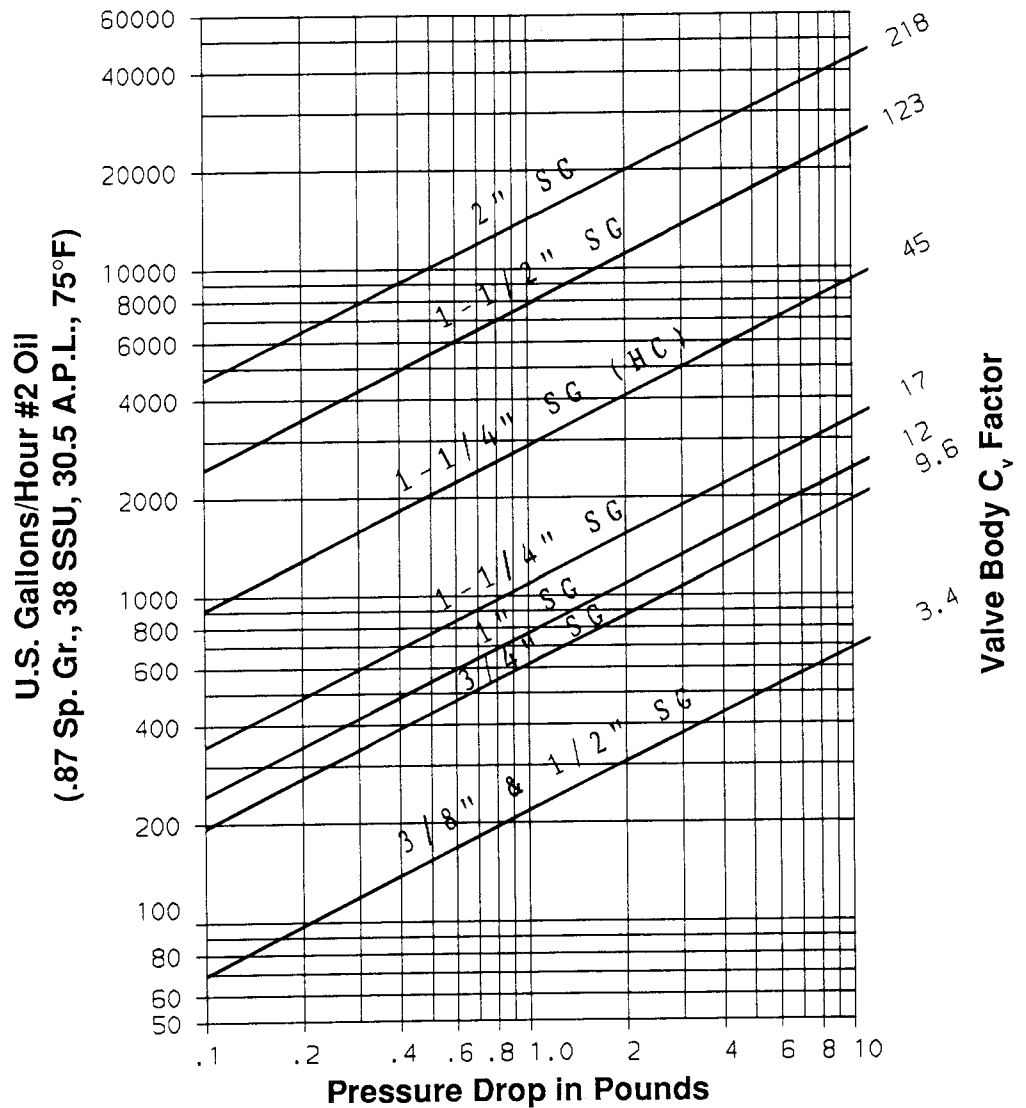

For preheated #5 or #6 oil, multiply the required flow rate in GPH by the factor given in the table at right, then select a valve based upon that equivalent flow of #2 oil and the allowable drop.

Oil Grade	#5		#6				
°F @ Inlet	125	160	120	140	180	210	220
Factor	1.43	1.11	2.86	2.00	1.25	1.11	1.05

For example: To size for 5 PSIG drop with a 3500 GPH flow of #6 oil preheated to 140°F, the multiplier is 2. Equivalent flow of #2 oil is then 3500 x 2, or 7000 GPH. Chart shows that a 5 PSIG drop will require use of a valve body having a C_v factor of at least 45.

Selection Data

Normally closed, swinging gate valves

Series Designation

Body Material>	Gray Iron		Cast Steel	
Top Assembly Function	Sanctioned Service [1]	Special Service (Non-sanctioned) [2]	Sanctioned Service [1]	Special Service (Non-sanctioned) [2]
Manual Reset	730	790	730-S; 760	790-S 33790; 23300
Automatic Reset	4730; 8730	4790; 8790	4730-S 4760; 8760	4790-S; 8790-S 33479; 25300

[1] Sanctioned valves are sold for fuel oils and may carry one or more sanctions (UL, FM, CGA). They are IRI approvable for liquified petroleum gases, #1 and #2 fuel oils, kerosene, JP-4 and preheated #4, #5 and #6 oils with maximum viscosity of 5000 SSU.

[2] Non-sanctioned valves do not carry blanket approval/listings, and the pressure limits shown apply only for selected special service applications. An analysis of your fluid will determine the actual rating, trim, and specifics for your application.

Temperature Limits

All of these valves can handle **fluid temperatures** from -20°F (-28°C) to +250°F (+121°C). The Series 33000 valves are designed to handle higher fluid temperatures up to +450°F (+232°C) and even up to +550°F (+288°C) with addition (at extra charge) of special stem seals.

Ambient temperature limits vary. Any valve on this page using DC voltage and all Series 8700 valves can handle ambient temperatures from -20°F (-28°C) to +125°F (+52°C). The other valves on this page handle ambient temperatures from -20°F (-28°C) to +140°F (+60°C).

Operation

All of these electro-mechanical valves require a constant supply of electrical energy to their holding solenoids inside the top assembly actuators. Once the solenoid is energized, the manual reset valve may be opened manually, or the automatic reset valve will automatically open. Any interruption of the electrical power to either of these valves causes an immediate trip of the valve to its normally closed position.

Available Sizes and Pressure Ratings

Pipe Size (inches)	Body C _v Flow Factor	Maximum Inlet Pressure (PSIG)			
		Gray Iron Bodies		Cast Steel Bodies	
		Fuel Oils	Special Service	Fuel Oils	Special Service
.375 [1]	3.4	300	300	---	---
.5 [1]				600	600
.75 [1]					
1	12	---	---	300	300
1.25	17				
1.25 HC	45				
1.5	123	---	---	150	150
2	218	---	---	100	100

[1] Available in 8730, 8760 & 8790

Shaded areas indicate 300# raised face flanged bodies.

Features:

- Normally closed
- Electrically actuated
- Swinging gate body
- For shut-off service
- For liquid and non-combustible gas service



1" Series 760

Selection Data

Normally closed, rising stem valves

Series Designation

Body Material>	Gray Iron		Cast Steel	
Top Assembly Function	Sanctioned Service [1]	Special Service (Non-sanctioned) [2]	Sanctioned Service [1]	Special Service (Non-sanctioned) [2]
Manual Reset	808; 808-CP	818; 818-CP	808-S; 808-S-CP	818-S; 818-S-CP
Automatic Reset	5000; 5000-CP 7000	5100; 5100-CP 7100	5000-S; 5000-S-CP 7000-S	5100-S; 5100-S-CP 7100-S

[1] Sanctioned valves may carry one or more sanctions (UL, FM, CGA) for air, natural and liquified petroleum gases. They are normally approvable for clean fuel gases. Additionally, series with internal trim -2 are sanctioned for #1 and #2 fuel oils (except Series 7000 (-S) are not listed FM approved for #2 fuel oil). 'SG' valves are preferable for liquid service (see page 6112).

[2] Non-sanctioned valves do not carry blanket sanctions, and the pressure limits shown apply only for selected special service applications. An analysis of your fluid will determine the actual rating, trim and specifics for your application.

Features:

- Normally closed
- Electrically actuated
- Rising stem body
- For shut-off service

Temperature Limits

All these valves can handle **fluid temperatures** from -20°F (-28°C) to +140°F (+60°C). Oil viscosity not to exceed 5000 SSU. **Ambient temperature limits vary.** Any valve on this page using DC voltage and all Series 7000 valves can handle ambient temperatures from -20°F (-28°C) to +125°F (+52°C). The other valves on this page handle ambient temperatures from -20°F (-28°C) to +140°F (+60°C).

Operation

All of these electro-mechanical valves require a constant supply of electrical energy to their holding device inside the top assembly actuators. (In Series 808 and 5000 valves, the device is a solenoid and Series 7000 valves use an electro-magnetic clutch.) Once that device is energized, the manual reset valve may be manually opened, or the automatic reset valve will automatically open. Any interruption of the electrical power to either of these valves causes an immediate trip of the valve to its normally closed position.

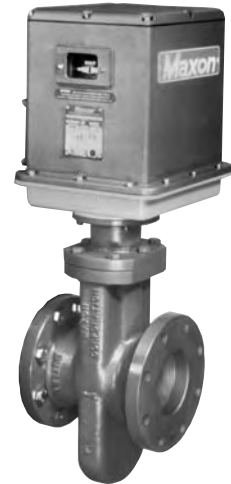

4" Series 7000

Available Sizes and Pressure Ratings

Pipe Size (inches)	Body C _v Flow Factor	Maximum Inlet Pressure (psi) [3]			
		Gray Iron Bodies		Cast Steel Bodies	
		Clean Gases	Special Service	Clean Gases	Special Service
.75	20	125	30	---	---
1		125	30	125	30
1.25	45	100	30	---	---
1.5	53	70	20	70	20
2	86	70	15	70	15
		70	15	70	15
2.5	127	40	10	---	---
		40	10	---	---
2.5 CP	304	50	15	50	15
		50	15	50	15
3	173	30	5	---	---
3 CP	423	40	10	40	10
		40	10	40	10
4 CP	490	40	10	40	10
4 HC [4]	719	60	10	60	10
6	869	30	5	30	5
6 HC [4]	1172	50	10	50	10

[3] Maximum operating pressure differential (MOPD) in psi must not exceed maximum inlet pressure shown.

[4] Series 7000 valves

NOTE: Shaded areas indicate flanged valve bodies. All others are threaded.

Selection Data

Normally open, rising stem valves

Series Designation

Body Material>	Gray Iron		Cast Steel	
Top Assembly Function	Sanctioned Service [1]	Special Service (Non-sanctioned) [2]	Sanctioned Service [1]	Special Service (Non-sanctioned) [2]
Manual Reset	STO-M	STO-M	STO-MS	STO-MS
Automatic Reset	STO-A STO-A-CP	STO-A STO-A-CP	STO-AS STO-AS-CP	STO-AS STO-AS-CP

[1] Sanctioned valves may carry one or more sanctions (UL, FM, CGA) for air, natural or liquefied petroleum gases. They are normally approvable for clean fuel gases. Additionally, series with internal trim -2 are sanctioned for #1 and #2 fuel oils.

[2] Non-sanctioned valves do not carry blanket sanctions, and the pressure limits shown apply only for selected special service applications. An analysis of your fluid will determine the actual rating, trim and specifics for your application.

Temperature Limits

All these valves can handle **fluid temperatures** from -20°F (-28°C) to +140°F (+60°C). Oil viscosity not to exceed 5000 SSU.

Ambient temperature limits vary. Any valve on this page using DC voltage can handle ambient temperatures from -20°F (-28°C) to +125°F (+52°C). The other valves on this page can handle ambient temperatures from -20°F (-28°C) to +140°F (+60°C).

Operation

All of these electro-mechanical valves require a constant supply of electrical energy to their holding solenoids inside the top assembly actuators. Once the solenoid is energized, the manual reset valve may be manually closed, or the automatic reset valve will automatically close.

Any interruption of the electrical power to either of these valves causes an immediate trip of the valve to its normally open position.

Features:

- Normally open
- Electrically actuated
- Rising stem body
- For vent and by-pass service



2.5" Series STO-ACP

Available Sizes and Pressure Ratings

Pipe Size (inches)	Body C _v Flow Factor	Maximum Inlet Pressure (psi) [3]			
		Gray Iron Bodies		Cast Steel Bodies	
		Clean Gases	Special Service	Clean Gases	Special Service
.75	20	125	30	---	---
1		125	30	125 [4]	30
1.5	53	70	20	70	20
2	86	70	15	70 [4]	15
		70	15	70	15
2.5 CP	304	50	15	50	15
		50	15	50	15
3 CP	423	40	10	40	10
		40	10	40	10
4 CP	490	40	10	40	10

[3] Maximum operating pressure differential (MOPD) in psi must not exceed maximum inlet pressures shown.

NOTE: Shaded areas indicate flanged valve bodies. All others are threaded.

Rising Stem Body/Trim Specifications

All Maxon Rising Stem Gate Valves carry a two-part trim identification (for example, Trim 1-1).

The first digit (a 1, 2, 3, 4 or 5 before the hyphen) identifies valve body and bonnet material as shown in Table 1 below.

The second digit (a 1, 2 or 3 after the hyphen) identifies the specific internals used, as described in Tables 2, 3 and 4, and identified in the sketches at right.

Internal trim -1 is normally suitable for clean fuel gases (for example, natural gas, propane, butane, clean atmosphere gases).

Internal trim -2 may be required for clean gases that require Viton seals or such gases as coke oven, refinery, town or off-gas.

Internal trim -3 is designed for more corrosive environments such as digester gas, sour natural gas and landfill gas. Contact Maxon with specific fuel analysis for prices and/or availability.

Normally closed and normally open threaded and flanged body versions are identical in material specifications.

The drawing at right carries item numbers matching those in Tables 2, 3 and 4. This information is furnished for identification only, not for ordering parts.

WARNING: Do not attempt field repair of Maxon valve body or electro-mechanical actuator. Any field alterations void all warranties.

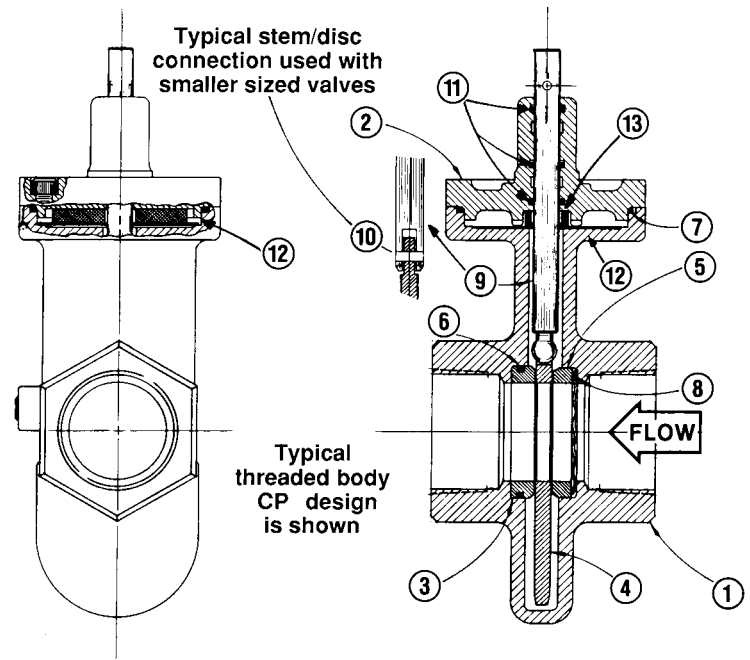

Table 1: Body (Item 1) and Bonnet (Item 2) Specifications

Body Description	Body 1-	Body 2-	Body 3-	Body 4-	Body 5 -
Material	Cast Iron, G3000, CL 30	Cast Steel	Cast Iron, G3000, CL 30	Cast Steel	Stainless Steel
Specifications	ASTM A159 / UL 429	ASTM A216-WCB / UL 429	ASTM A159 / UL 429	ASTM A216-WCB / UL 429	A351-CF8M
Special Coating	---	---	Electroless Nickel-Coated	Electroless Nickel-Coated	---

Table 2: Internal Trim Specifications

Item No.	Description	Trim: -1			
		.75" - 2"	2.5", 3"	2.5" - 4" CP	6"
3	Seat	#440-F Stainless Steel	#416 Stainless Steel	#440-F Stainless Steel	#303 Stainless Steel
4	Disc	80-55-06 Ductile Iron	80-55-06 Ductile Iron	80-55-06 Ductile Iron	80-55-06 Ductile Iron
5	Follow Ring	Lead alloy (nickel plated)	Ductile Iron (nickel plated)	Low-Carbon Steel (nickel plated)	Low-Carbon Steel (nickel plated)
6	Seat O-Ring	Buna N	Buna N	Buna N	Buna N
7	Gasket	Buna N	Buna N	Buna N	Steel
8	Wavy-Spring Washer	#302 Stainless Steel	#302 Stainless Steel	#302 Stainless Steel	#302 Stainless Steel [1]
9	Stem	Type 630 Stainless Steel	Type 630 Stainless Steel	Type 630 Stainless Steel	Type 630 Stainless Steel
10	Stem/Disc Pins	High Carbon Steel (hardened)	High Carbon Steel (hardened)	---	Shear-Proof Steel
11	Stem O-Rings	Buna N	Buna N	Buna N	Buna N
12	Striker Plate	#17-7 Stainless Steel	#17-7 Stainless Steel	#17-7 Stainless Steel	Carbon Steel (6" 808 only)
13	Bumper	Buna N	Buna N	Buna N	Buna N
---	Clevis [2]	---	---	---	Ductile Iron

[1] Compression Spring [2] For 6" 808 and 4" & 6" 7000 valves only; not shown in illustration above

Rising Stem Body/Trim Specifications

Table 3: Internal Trim Specifications for Trim -2

Item No.	Description	Trim: -2		
		.75" – 2"	2.5" – 4" CP	6"
3	Seat	#303 SS (hard faced)	#303 SS (hard faced)	#303 SS (hard faced)
4	Disc	80-55-06 Ductile Iron (chrome plated)	80-55-06 Ductile Iron (chrome plated)	80-55-06 Ductile Iron (chrome plated)
5	Follow Ring	303 SS (chrome plated)	303 SS (chrome plated)	303 SS (chrome plated)
6	Seat O-ring	Viton	Viton	Viton
7	Bonnet O-ring	Viton	Viton	Steel
8	Wavy-Spring Washer	#302 Stainless Steel	#302 Stainless Steel	#302 Stainless Steel
9	Stem	Type 630 Stainless Steel	Type 630 Stainless Steel	Type 630 Stainless Steel
10	Stem/Disc Pins	#420 Stainless Steel	---	Shear-Proof Steel
11	Stem O-rings	Viton	Viton	Viton
12	Striker Plate	#17-7 Stainless Steel	#17-7 Stainless Steel	Carbon Steel
13	Bumper	Viton	Buna N*	Viton

*For oxygen service, bumper material is EPDM

Table 4: Internal Trim Specifications for Trim -3

Item No.	Description	Trim: -3		
		.75" – 2"	2.5" – 4" CP	6"
3	Seat	PEEK	PEEK	PEEK
4	Disc	A351-CF8M	A351-CF8M	A351-CF8M
5	Follow Ring	PEEK	PEEK	PEEK
6	Seat O-ring	Viton	Viton	Viton
7	Bonnet O-ring	Viton	Viton	Viton
8	Wavy-Spring Washer	#302 Stainless Steel	#302 Stainless Steel	#302 Stainless Steel
9	Stem	Type 630 Stainless Steel	Type 630 Stainless Steel	Type 630 Stainless Steel
10	Stem/Disc Pins	---	---	---
11	Stem O-rings	Viton	Viton	Viton
12	Striker Plate	#17-7 Stainless Steel	#17-7 Stainless Steel	#17-7 Stainless Steel
13	Bumper	Viton	Buna N*	Viton

*For oxygen service, bumper material is EPDM

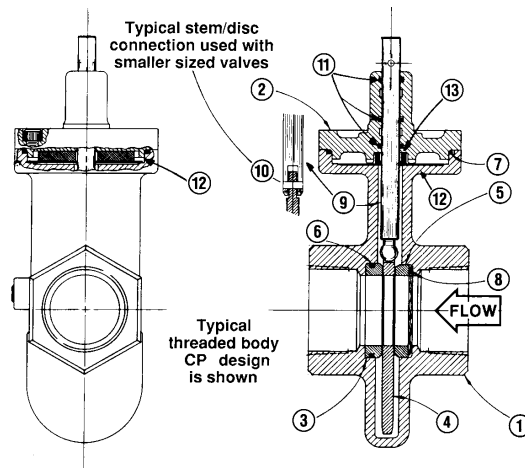

Swinging Gate Body/Trim Specifications

Trim identification of Maxon Swinging Gate Shut-Off Valves is two-part. The first digit before the hyphen is a number (1, 2, 3 or 4) identifying body material as shown in Table 1 below. The second digit after the hyphen identifies a trim utilizing the materials indicated in Table 2 below.

Standard sanctioned valves incorporating a *cast iron body* will normally be identified by trim 1-B or 1-D. Sanctioned valves with *steel body* will normally be trim 2-D.

Non-sanctioned services or unusual applications may require upgrading of internal trim. Contact Maxon with specific fuel analysis for price and availability.

The drawings shown on the following page carry item numbers matching those in Table 2. This information is furnished for identification only, not for ordering parts.

WARNING: Do not attempt field repair of Maxon valve body or electro-mechanical top actuator. Any field alterations void all warranties.

Table 1: Body (Item 1) Specifications

Body Description	Body 1-	Body 2-	Body 3-	Body 4-
Material	Cast Iron, G3000, CL 30	Cast Steel	Cast Iron, G3000, CL 30	Cast Steel
ASTM Spec	A159	A216-WCB	A159	A216-WCB
Special Coating	---	---	Electroless Nickel-Coated	Electroless Nickel-Coated

Table 2: Internal Trim Material Specifications

Item No.	Part Description	for .375" & .75" valves		For 1" & 1.25" valves			For 1.5" & 2" valves	
		Trim: -D	Trim: -N	Trim: -B	Trim: -D	Trim: -N	Trim: -B	Trim: -D
2	Hex Nut or Renewable Seat	Hard-Faced Steel	Hard-Faced Steel	Cast Iron with #420 Stainless Steel Seat Ring	Hard-Faced Steel	Hard-Faced Steel	Cast Iron with #420 Stainless Steel Seat Ring	Hard-Faced Steel
3	Stem Bushing	Zinc-Plated Steel	Zinc-Plated Steel	Zinc-Plated Steel	Zinc-Plated Steel	Zinc-Plated Steel	#416 Stainless Steel	#416 Stainless Steel
4	Stem	#416 Stainless Steel	#416 Stainless Steel	#416 Stainless Steel	#416 Stainless Steel	#416 Stainless Steel	#416 Stainless Steel	#416 Stainless Steel
5	Stem Spring	#302 Stainless Steel	#302 Stainless Steel	#302 Stainless Steel	#302 Stainless Steel	#302 Stainless Steel	#302 Stainless Steel	#302 Stainless Steel
6	Disc Carrier	Steel	Steel w/Nedox coating	Steel	Steel	Steel w/Nedox coating	Steel	Steel
7	Disc	Hard-Faced Steel	Hard-Faced Steel	Nodular Iron	Hard-Faced Steel	Hard-Faced Steel	Nodular Iron	Hard-Faced Steel
8	Stem O-Rings	Hydrin	Hydrin	Viton	Viton	Viton	Viton	Viton
9	Disc Spring	#302 Stainless Steel	#302 Stainless Steel	#302 Stainless Steel	#302 Stainless Steel	#302 Stainless Steel	#302 Stainless Steel	#302 Stainless Steel
10	Inner Stem Thrust Ring	Teflon	Teflon	Teflon	Teflon	Teflon	Grafoil	Teflon
11	Back-up O-Rings	Teflon	Teflon	Teflon	Teflon	Teflon	---	---
12	Body Gaskets	Soft Iron	Soft Iron	Soft Iron	Soft Iron	Soft Iron	Soft Iron	Soft Iron
13	Stem Bushing Gasket	Soft Iron	Soft Iron	Soft Iron	Soft Iron	Soft Iron	Soft Iron	Soft Iron
14	Body O-Ring	Viton	Viton	Viton	Viton	Viton	---	---
15	Stem Packing Ring	Grafoil	Grafoil	---	---	---	---	---
16	Packing Nut	Zinc-Plated Steel	Zinc-Plated Steel	---	---	---	---	---
17	Outlet Flange	---	---	---	---	---	Steel (same as body material)	Steel (same as body material)

Swinging Gate Body/Trim Specifications

Typical construction of
.375" through .75" screwed body valves

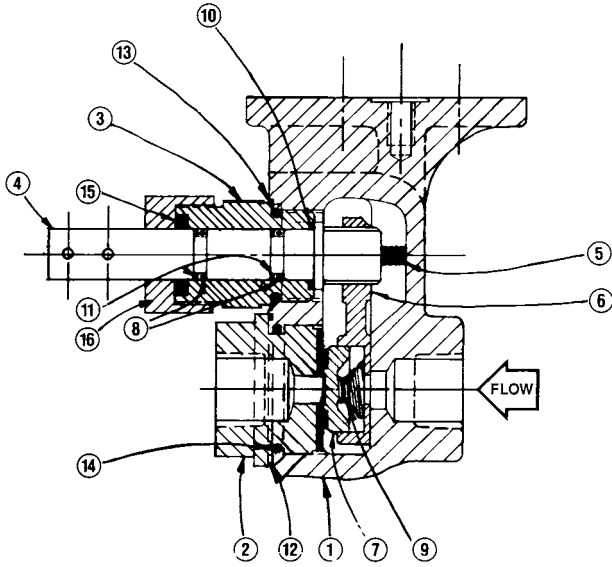

Typical construction of
1" through 2" screwed body valves

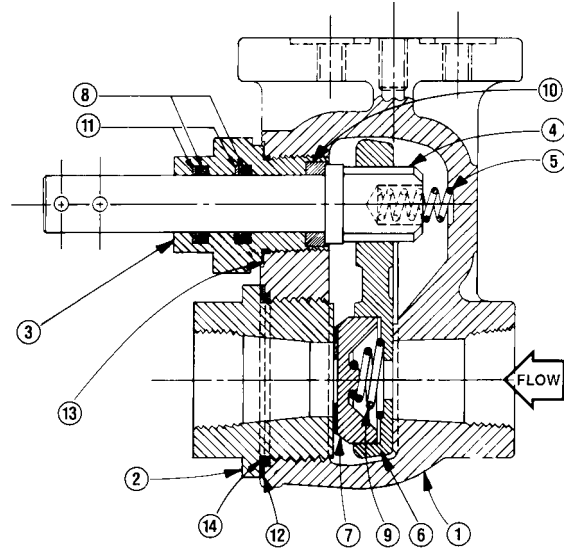

Typical construction of
1.5" through 2" flanged body valves

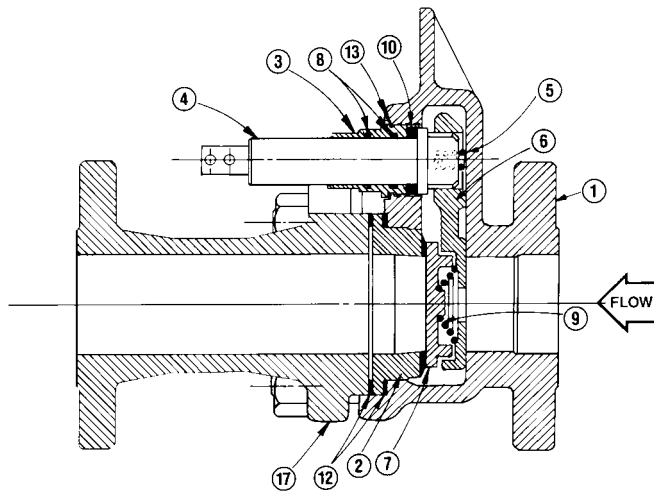

Component Identification

General Maintenance and Spare Parts

All safety devices should be tested at least monthly* and more often if deemed advisable. Periodic testing for tightness of manual or motorized shut-off valve closure is equally essential.

*per NFPA 86-Appendix B-4 (1995)

These Maxon valves are designed for long trouble-free service. Only items shown as suggested spare parts are considered field replaceable.

WARNING: Do not attempt field repair of valve body, top assembly or motor drive unit. Any alterations void all warranties.

To determine suggested spare parts, identify series designation and serial number from the valve's nameplate. Refer to the illustration and legend below to identify suggested spare parts.

To order, specify:

1. Quantity
2. Assembly part number (if available)
3. Description
4. Electrical specification
5. Full nameplate information (from existing valve)

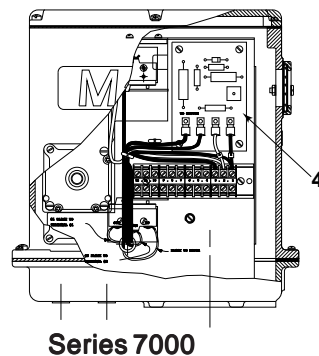
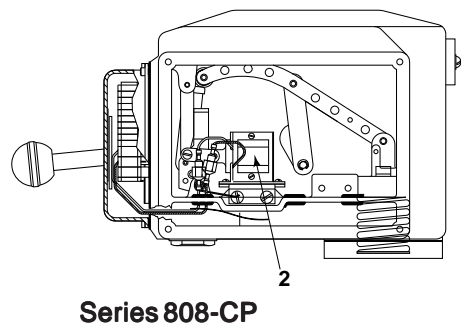
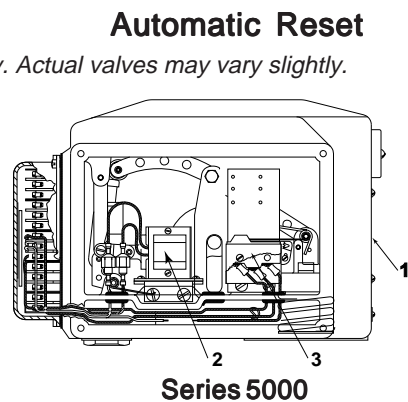
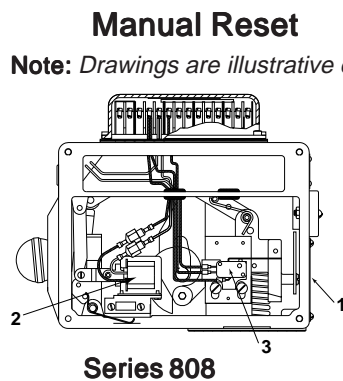

Legend:

- ① – Nameplate
- ② – Solenoid
- ③ – VOS motor limit/signal switch for normally closed valve; VCS for normally open valve
- ④ – Printed Circuit Board (PCB)

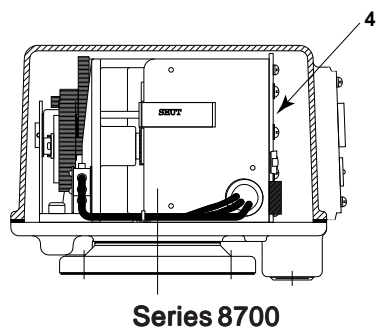

Nameplate (typical)

(shown for listed valves; others similar)

Nameplate designation does not reflect external accessory items or motor limit switch

Normally closed valve designation

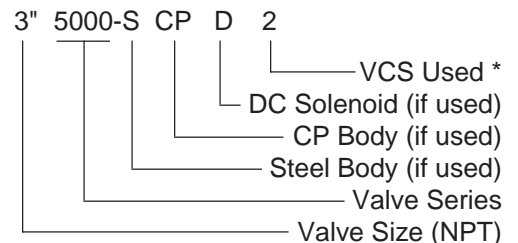

***Signal Switch legend:**

- 0 No Switch
- 1 VCS-1 Switch
- 2 VCS-2 Switch
- 2H VCS-2 (Herm. Sealed)
- 1H VCS-1 (Herm. Sealed)

Normally open valve designation

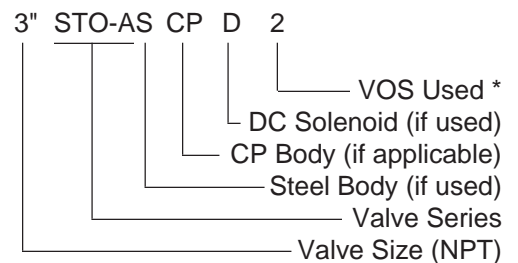

***Signal Switch legend:**

- 0 No Switch
- 1 VOS-1 Switch
- 2 VOS-2 Switch
- 2H VOS-2 (Herm. Sealed)
- 1H VOS-1 (Herm. Sealed)

Electrical Data for normally closed valves

General

All Maxon shut-off valves are electrically actuated from a power source, normally through the flame safeguard and/or safety control circuits.

Standard valve assemblies include an internal holding solenoid or printed circuit board for 115 volt 60 hertz AC power. (Other electrical current options are available upon request.)

Series 808, 730, 760, 5000, 4730, and 4760 valves have the internal solenoid. Series 8700 and 7000 valves incorporate the printed circuit board.

The solenoid (or the printed circuit board) is energized whenever the valve is powered. The motor operator on automatic reset versions is powered only during the opening stroke.

Switch wiring diagrams (reproduced on the next page) are part of each valve assembly, summarizing electrical data and wiring for a valve equipped with terminal block and a full complement of optional signal switches.

Diagrams show valve in its normally closed (at rest) position. The indicated internal wiring is present only when the appropriate auxiliary switches are specified. Automatic reset valves always include a VOS-1 SPDT valve open motor limit switch.

Good practice *normally* dictates that auxiliary switches in valves used for safety shut-off functions should be used for signal duty **only**, not to operate additional safety devices.

Signal switch designations:

VCS (Valve Closed Switch) is actuated at the end of the closing stroke. VCS-1 is SPDT; VCS-2 is DPDT.

VOS (Valve Open Switch) is actuated at the end of the opening stroke. VOS-1 is SPDT; VOS-2 is DPDT.

Switch amp ratings are shown on the schematic wiring diagrams on page 6122. **DO NOT EXCEED** rated amperage or total load shown.

Volt Ampere (VA) Ratings: Manual Reset

Valve		AC Operation		DC Operation	
Size	Series	Opening	Holding	Opening	Holding
.75" – 1.5"	808, 818 (-S)	22	22	14	14
2" - 3"	808, 818 (-S)	22	22	24	24
1" - 1.25"	730, 760, 790 (-S)	22	22	24	24
1.5" - 2"	23300	22	22	24	24
1" - 1.25"	33790	22	22	24	24
2.5" - 4"	808-CP, 818 -CP (-S)	34	34	24	24
6"	808, 818 (-S)	34	34	---	---

Volt Ampere (VA) Ratings: Automatic Reset

Valve		AC Operation (115 VAC, 60 Hz)		DC Operation (24 VDC)	
Size	Series	Opening	Holding	Opening	Holding
.75" – 1.5"	5000, 5100 (-S)	220 [1]	22	212	14
2" - 3"	5000, 5100 (-S)	220 [1]	22	222	24
1" – 1.25"	4730, 4760, 4790 (-S)	220 [1]	22	222	24
1.5" – 2"	25300	220 [1]	22	222	24
1" – 1.25"	33479	220 [1]	22	222	24
2.5" – 4"	5000-CP, 5100-CP (-S)	232 [2]	34	222	24
4" – 6"	7000, 7100 (-S)	376	8	428 [3]	8 [3]
.375" – .75"	8730, 8760, 8790 (-S)	143	5	---	---

[1] 220 VA shown is for 60 hertz; if 50 hertz power, VA rating is 342

[2] 232 VA shown is for 60 hertz; if 50 hertz power, VA rating is 354

[3] Based on 120 VDC

NOTE: The VA rating shown in the DC column is based on an AC motor, DC solenoid.

Electrical Data for normally closed valves

Manual Reset Series:

- .75" - 3" Series 808, 818 (-S);
- 1" - 1.25" Series 730, 760, 790 (-S);
- 1" - 1.25" Series 33790 (-S);
- 2.5" - 4" Series 808-CP, 818-CP (-S);
- 6" Series 808, 818 (-S)

Automatic Reset Series:

- .75" - 3" Series 5000, 5100 (-S);
- 1" - 1.25" Series 4730, 4760, 4790 (-S);
- 1" - 1.25" Series 33479;
- 2.5" - 4" Series 5000-CP, 5100-CP (-S)

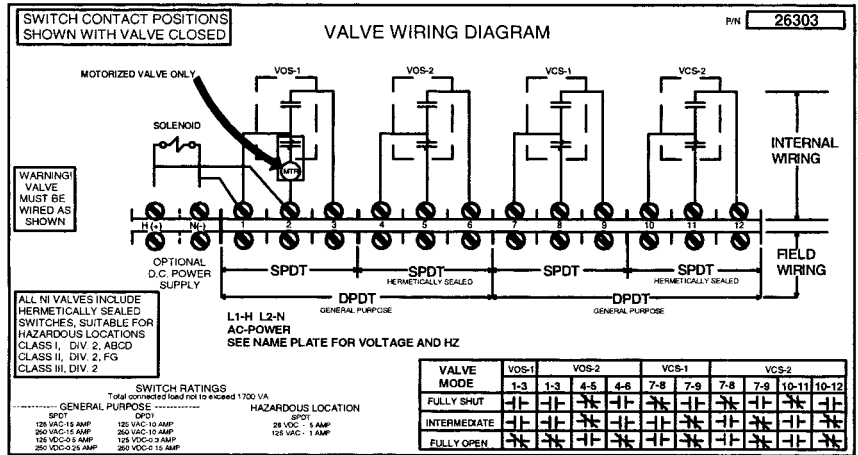

4" - 6" Series 7000, 7100 (-S)

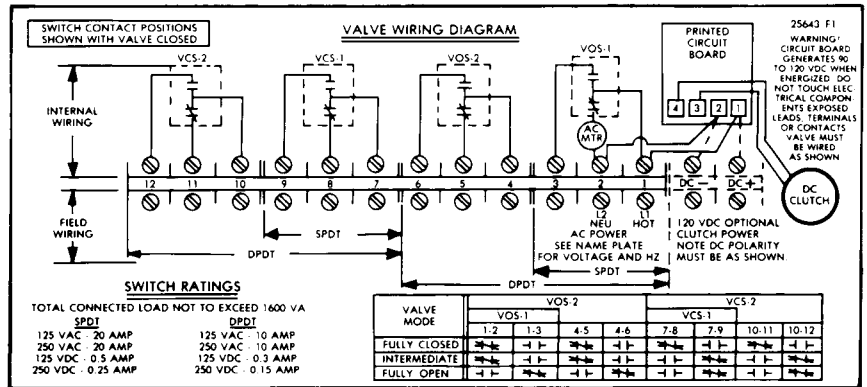

.375" through .75" Series 8730, 8760, and 8790 (-S)

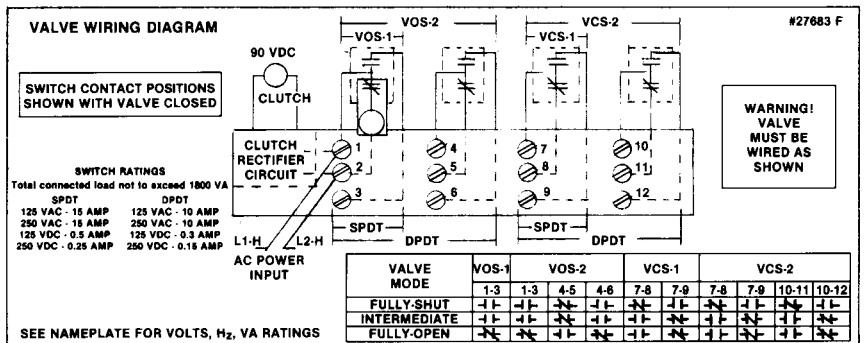

Electrical Data for normally open valves

General

All Maxon normally open vent valves are electrically actuated from a power source, normally through the flame safeguard and/or safety control circuits.

Standard valve assemblies include an internal holding solenoid for 115 volt 60 hertz AC power. (Other electrical current options are available upon request.)

The solenoid is energized whenever the valve is powered. The motor operator on automatic reset version is powered only during the closing stroke.

Switch wiring diagrams (reproduced below and on next page) are part of each valve assembly, summarizing electrical data and wiring for a valve equipped with terminal block and a full complement of optional signal switches.

Diagrams show valve in its normally open (at rest) position. The indicated internal wiring is present only when the appropriate auxiliary switches are specified. Automatic reset valves always include a VCS-1 SPDT valve closed motor limit switch.

Good practice *normally* dictates that auxiliary switches in valves used for safety shut-off functions should be used for signal duty **only**, not to operate additional safety devices.

Signal switch designations:

VCS (Valve Closed Switch) is actuated at the end of the closing stroke. VCS-1 is SPDT; VCS-2 is DPDT.

VOS (Valve Open Switch) is actuated at the end of the opening stroke. VOS-1 is SPDT; VOS-2 is DPDT.

Switch amp ratings are shown on the schematic wiring diagrams below and on the next page. DO NOT EXCEED rated amperage or total load shown.

Volt Ampere (VA) Ratings

Valve		AC Operation		DC Operation	
Size	Series	Closing	Holding	Closing	Holding
.75" - 1.5"	STO-M	22	22	14	14
2" - 3"	STO-M	22	22	24	24
2.5" - 4"	STO-M CP	34	34	24	24
.75" - 1.5"	STO-A	220 [1]	22	212	14
2" - 3"	STO-A	220 [1]	22	222	24
2.5" - 4"	STO-A CP	232 [2]	34	222	24

[1] 220 VA is for 60 hertz; if 50 hertz, then VA is 342

[2] 232 VA is for 60 hertz; if 50 hertz, then VA is 354

The VA rating shown in the DC column is based on an AC motor, DC solenoid.

.75" - 2" Series STO-M and STO-A (-S) 2.5" - 4" Series STO-M-CP and STO-A-CP (-S)

SWITCH CONTACT POSITIONS SHOWN WITH VALVE OPEN

P/N 26379M

VALVE WIRING DIAGRAM

MOTORIZED VALVE ONLY

WARNING! VALVE MUST BE WIRED AS SHOWN

ALL NI VALVES INCLUDE HERMETICALLY SEALED SWITCHES, SUITABLE FOR HAZARDOUS LOCATIONS
CLASS I, DIV. 2, ABCD
CLASS II, DIV. 2, FG
CLASS III, DIV. 2

SWITCH RATINGS
Total connected load not to exceed 1700 VA

GENERAL PURPOSE		HAZARDOUS LOCATION
SPDT	DPDT	SPDT
125 VAC - 15 AMP	125 VAC - 10 AMP	28 VDC - 5 AMP
250 VAC - 15 AMP	250 VAC - 10 AMP	125 VAC - 1 AMP
125 VDC - 0.5 AMP	125 VDC - 0.3 AMP	
250 VDC - 0.25 AMP	250 VDC - 0.15 AMP	

VALVE MODE

	VCS-1		VCS-2		VOS-1		VOS-2			
	1-3	1-3	4-5	4-6	7-8	7-9	7-8	7-9	10-11	10-12
FULLY OPEN	+	+	+	+	+	+	+	+	+	+
INTERMEDIATE	+	+	+	+	+	+	+	+	+	+
FULLY SHUT	+	+	+	+	+	+	+	+	+	+

L1-H L2-N AC-POWER
SEE NAME PLATE FOR VOLTAGE AND HZ

Dimensions (in Inches) 808, 5000, STO-A, STO-M

.75" through 1.5" valves with rising stem bodies

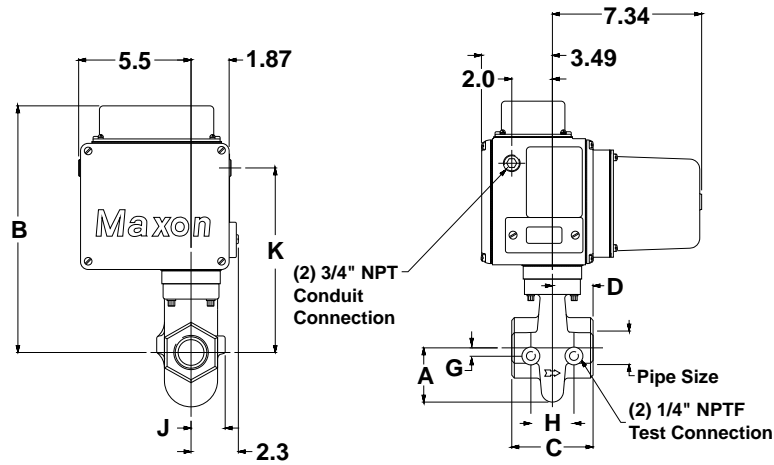

5000 & STO-A

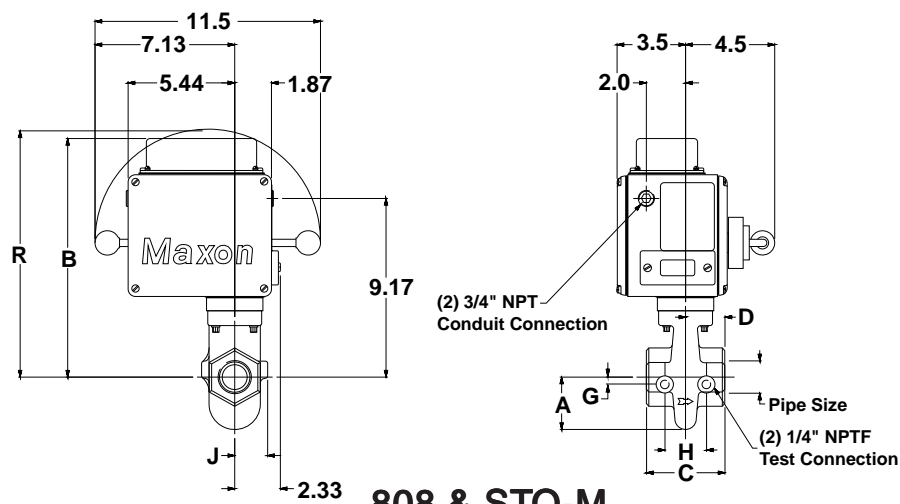

808 & STO-M

Available Top Assembly Positions

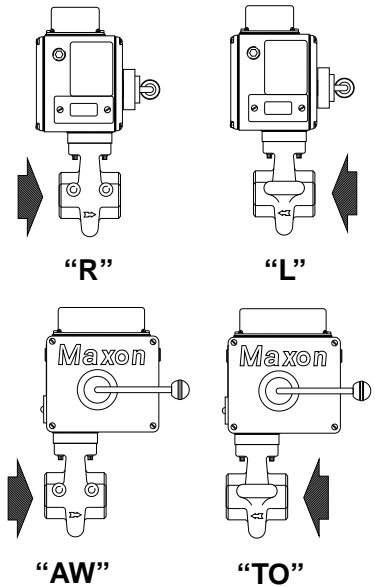

NOTE: 2.75" needed for terminal block cover removal.

Pipe Size	Valve Series	A	B	C	D	G	H	J	K	R
.75"	808 & STO-M	2.00	12.25	3.81	1.90	.78	1.94	.81	8.11	11.58
	5000 & STO-A									---
1"	808 (-S) & STO-M (-S)	2.00	12.25	3.81	1.90	.78	1.94	.81	8.11	11.58
	5000 (-S) & STO-A (-S)									---
1.25"	808	2.44	12.81	4.00	2.00	.22	2.12	1.56	8.67	12.14
	5000									---
1.5"	808 (-S) & STO-M (-S)	2.69	13.31	4.00	2.00	.38	2.12	1.68	9.14	12.61
	5000 (-S) & STO-A (-S)									---

Dimensions (in Inches) 808-CP, 5000-CP, STO-MCP, STO-ACP

2.5" CP through 4" CP and 6" valves with rising stem bodies

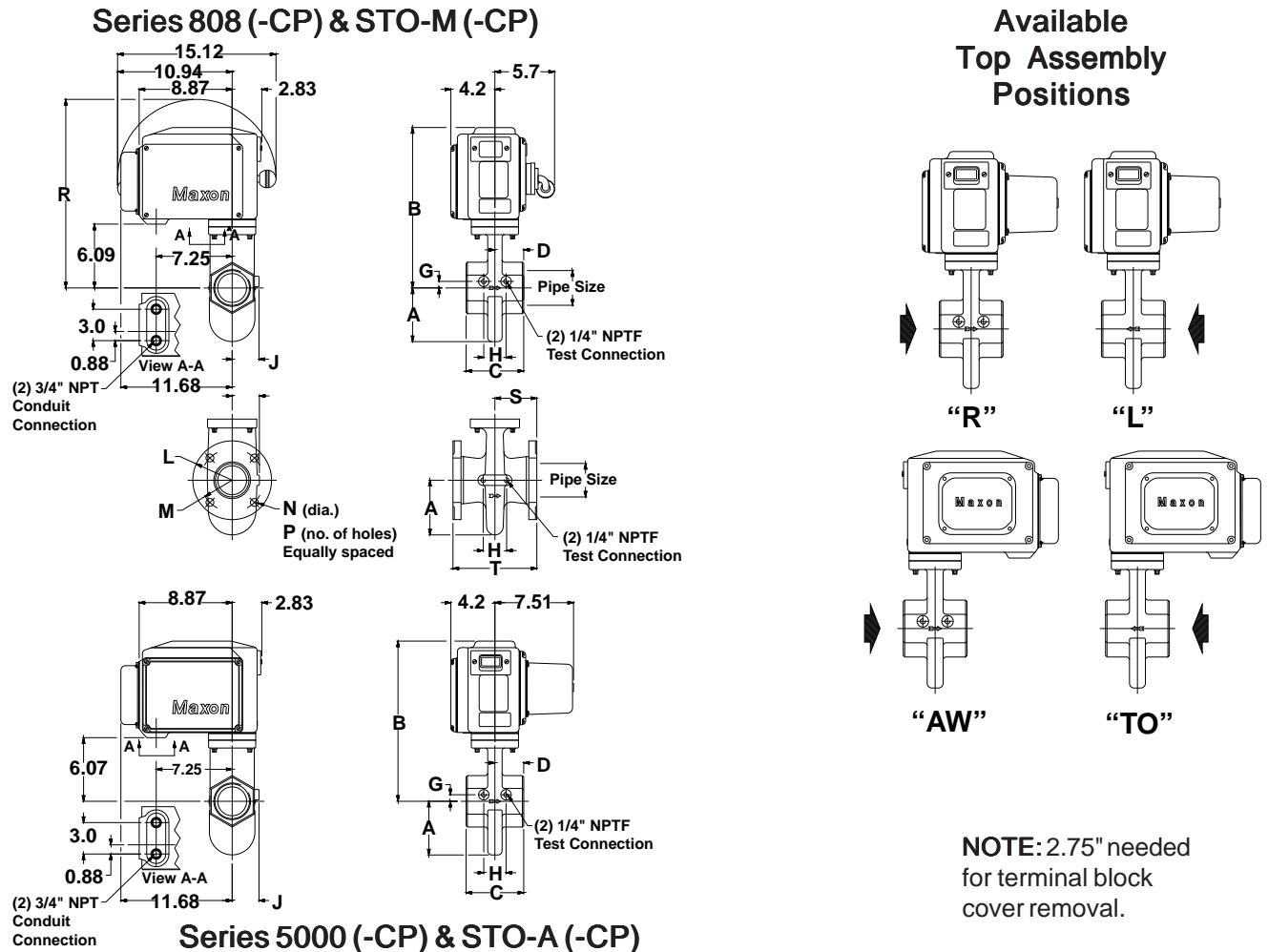

Pipe Size	Valve Series	A	B	C	D	G	H	J	L	M	N	P	R	S	T
2.5" CP	808 (-SCP)	4.31	14.56	5.0	2.5	.50	2.12	2.25	---	---	---	---	14.56	---	---
	5000 (-SCP), STO-A (-SCP)			---	---	---		---	---	---	---				
2.5" F CP	808 (-SCP)	4.5	15.29	---	---	---	2.24	2.2	3.5	2.75	.75	4	14.56	3.75	7.5
	5000 (-SCP), STO-A (-SCP)			---	---	---		---	---	---	---	---	---	---	---
3" CP	808 (-SCP)	5.12	15.29	5.5	2.75	.62	2.12	2.56	---	---	---	---	17.97	---	---
	5000-CP, STO-ACP												---		
	5000 (-SCP), STO-A (-SCP)												17.97		
3" F CP	808 (-SCP)	5.22	15.29	---	---	---	2.24	2.6	3.75	3.0	.75	4	17.97	4.0	8.0
	5000 (-SCP), STO-A (-SCP)												---		
4" F CP	808 (-SCP)	5.55	15.29	---	---	---	2.25	2.56	4.5	3.75	.75	8	17.97	4.5	9.0
	5000 (-SCP), STO-A (-SCP)												---		
6"	808	7.5	20.75	---	---	---	3.38	---	5.5	4.75	.88	8	23.43	5.25	10.5

Dimensions (in Inches) 4" & 6" 7000 Valves

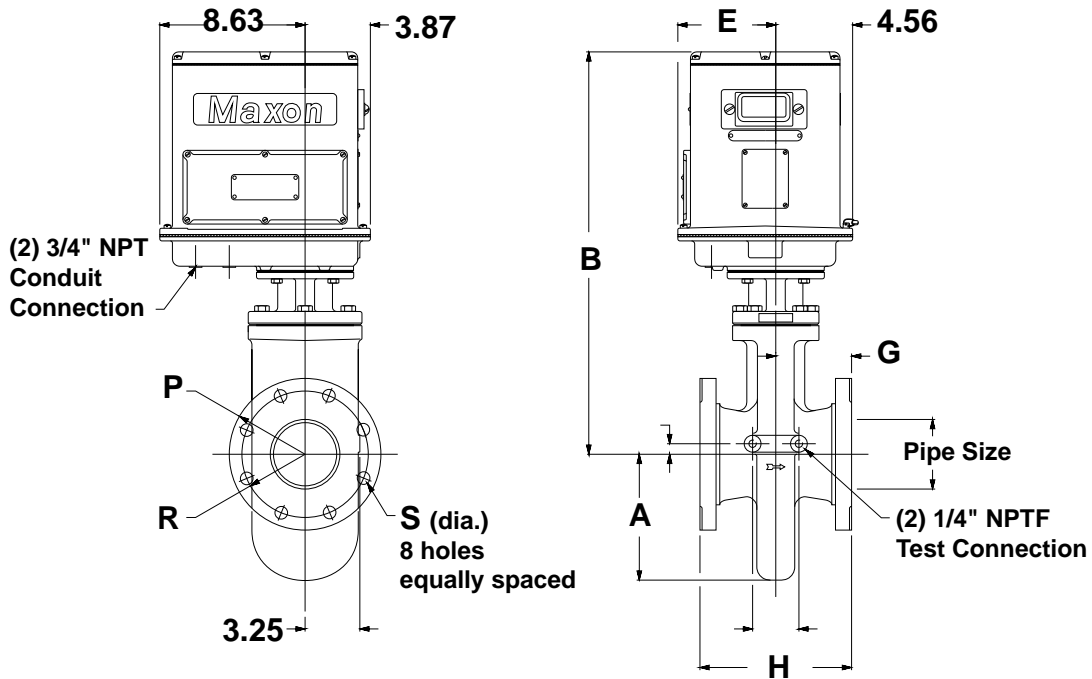

Available Top Assembly Positions

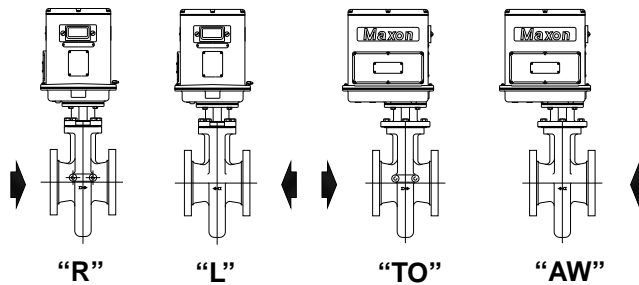

Valve Size	Valve Series	A	B	E	G	H	P	R	S
4"	7000 (-S) & 7100 (-S)	7.31	23.88	4.19	4.5	9	4.5	3.75	0.75
6"	7000 (-S) & 7100 (-S)	8.38	25	5.81	5.25	10.5	5.5	4.75	0.88

Dimensions (in Inches) 8700, 23300, 25300

.375" through 2" valves with swinging gate bodies

Series 8730, 8760, 8790 & 8790-S (.375", .5" & .75")

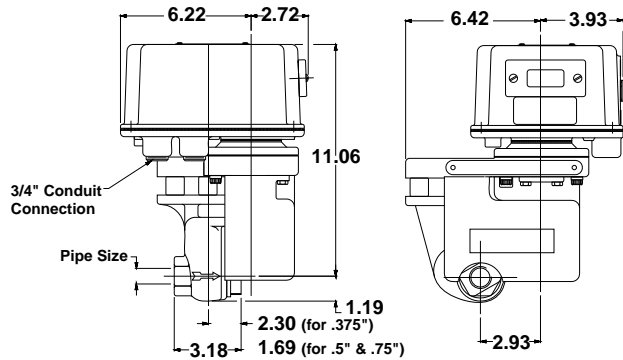

Note: Series 8700 valves are available in top assembly positions "R" and "TO" only.

Series 23300 & 25300 (1.5" & 2")

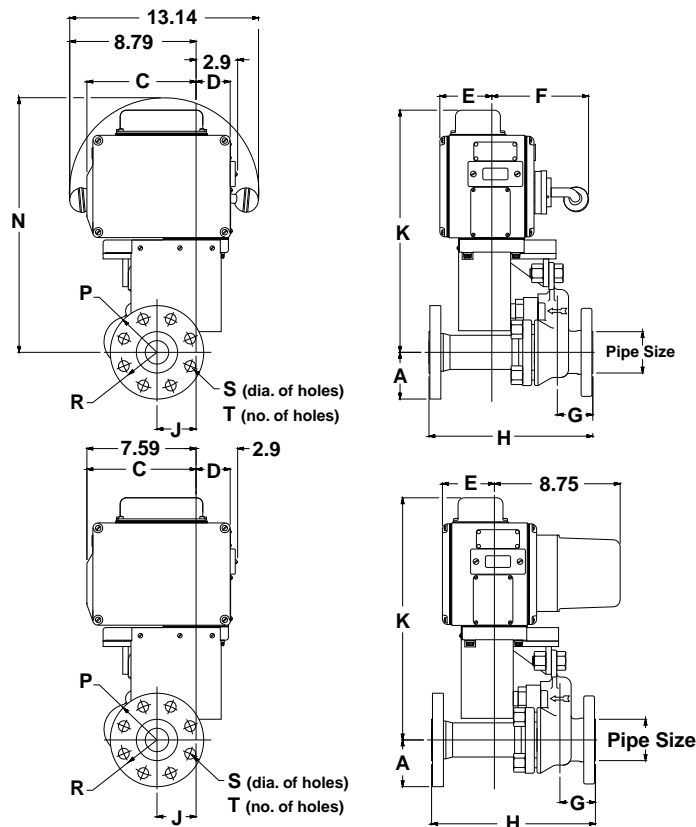

Available Top Assembly Positions for Series 23300 & 25300

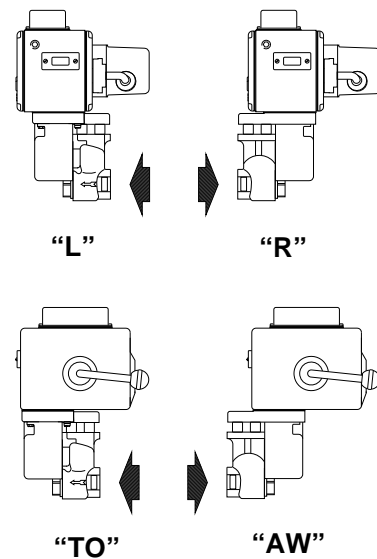

NOTE: 2.75" needed for terminal block cover removal.

Valve Size	Valve Series	A	C	D	E	F	G	H	J	K	N	P	R	S	T
1.5"	23300 & 25300	3.06	7.62	2.38	3.5	5.62	2.44	11.44	2.72	18.00	18.00	3.06	2.25	0.88	4
2"	23300 & 25300	3.25					2.69	11.94		18.37	18.37	3.25	2.5	0.75	8

Dimensions (in Inches)

4700, 700, 33479, 33790

1" & 1.25" valves with swinging gate bodies

1" & 1.25" Series 700, 4700

1" & 1.25" Series 33790, 33479

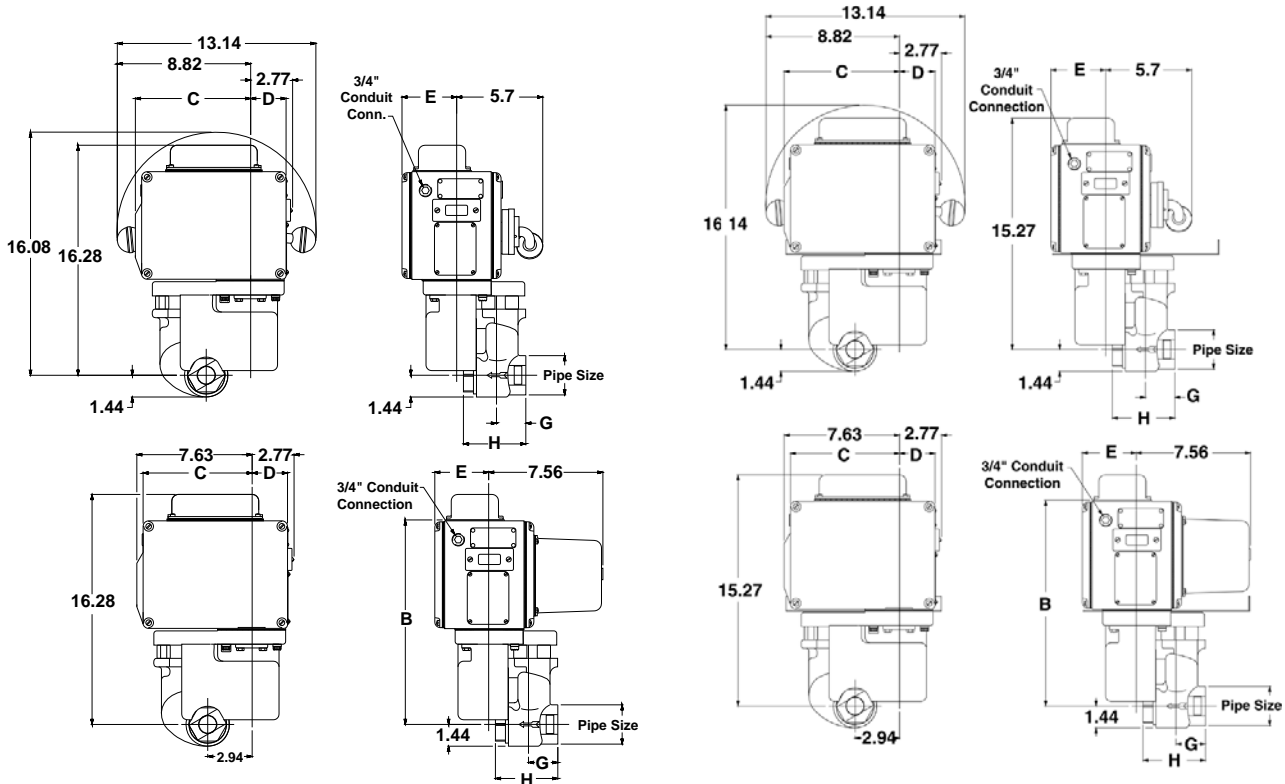

NOTE: 2.75" needed for terminal block cover removal.

Available Top Assembly Positions

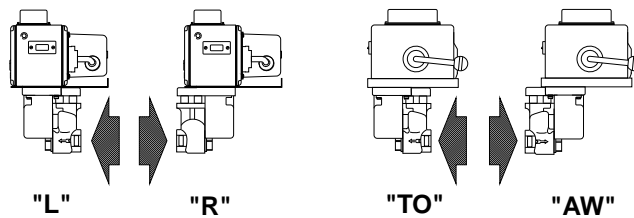

Valve Size	Valve Series	B	C	D	E	G	H
1"	730, 760, 790 & 790-S	13.53	7.62	2.38	3.5	1.94	4.12
	4730, 4760, 4790 & 4790-S						
	33790 & 33479	---					4.19
1.25"	730, 760, 790 & 790-S	13.53	7.62	2.38	3.5	1.94	4.12
	4730, 4760, 4790 & 4790-S						
	33790 & 33479	---					4.19

Auxiliary Signal Switches

All Maxon valves may be equipped with internally-mounted signal switch(es) to provide a “proof-of-open” or “proof-of-closure” valve position indication.

Auxiliary signal switches indicate when valve is open or closed and are normally connected electrically into your control panel lights or warning device circuit(s).

For normally-closed valves:

VCS (Valve Closed Switch) is actuated when valve is fully shut. It is the upper, inverted snap-switch mounted on rear of switch bracket. VCS-1 is an SPDT (single-pole, double-throw) switch. VCS-2 is a DPDT (double-pole, double-throw) switch. All contacts are available for external circuitry.

VOS (Valve Open Switch) is actuated when valve reaches full-open. It is the lower snap-switch mounted

on front of switch bracket. VOS-1 is an SPDT switch. On automatic reset valves, its normally closed contact serves as a motor limit switch and is not available for external circuitry. On manual reset valves, normally closed contact is available for external circuitry, but is not wired to optional terminal block. VOS-2 is DPDT, used in lieu of VOS-1 for additional contacts.

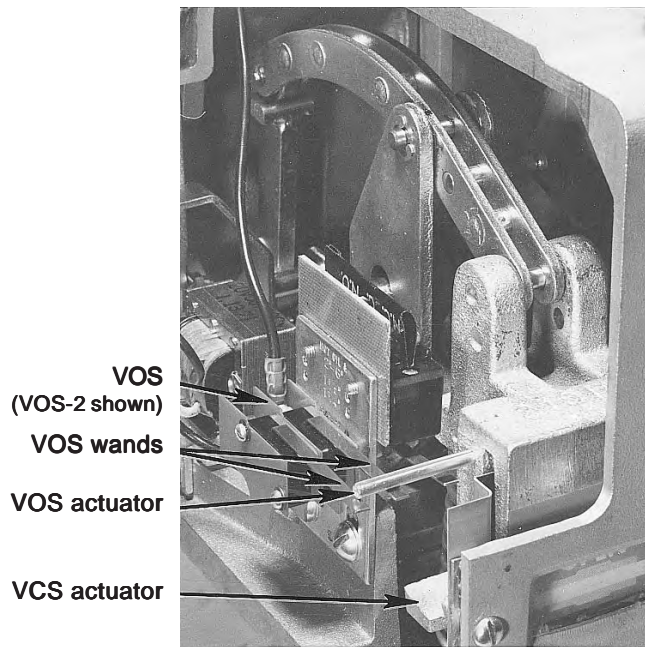

Valve Open

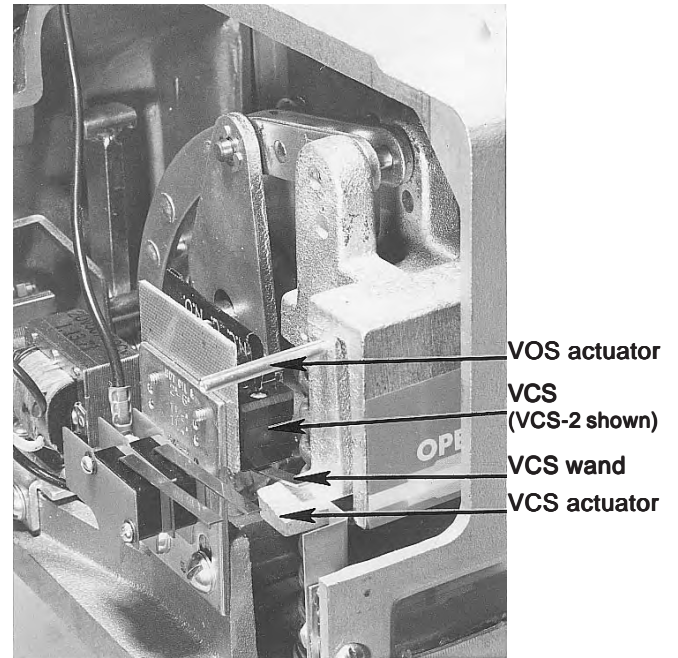

Valve Shut

Photos above of normally-closed valve
(typical for Series 730, 760, 790, 808, 818, 5000, 5100, 4730, 4760, 4790)

Auxiliary Signal Switches

For normally-open valves:

VOS (Valve Open Switch) is actuated when valve is fully open. It is the upper, inverted snap-switch mounted on rear of switch bracket. VOS-1 is an SPDT (single-pole, double-throw) switch. VOS-2 is a DPDT (double-pole, double-throw) switch. All contacts are available for external circuitry.

VCS (Valve Closed Switch) is actuated when valve reaches fully-closed. It is the lower snap-switch

mounted on front of switch bracket. VCS-1 is an SPDT switch. On automatic reset valves, its normally closed contact serves as a motor limit switch and is not available for external circuitry. On manual reset valves, normally closed contact is available for external circuitry, but is not wired to optional terminal block. VCS-2 is DPDT, used in lieu of VCS-1 for additional contacts.

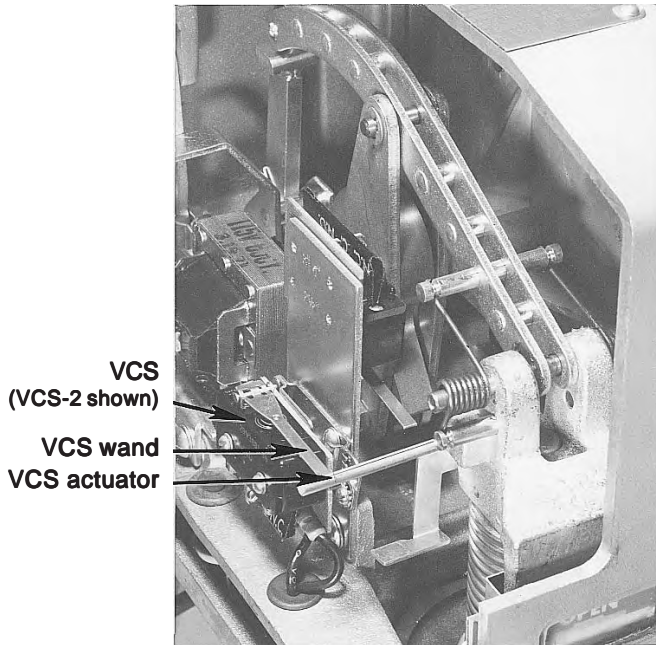

Valve Shut

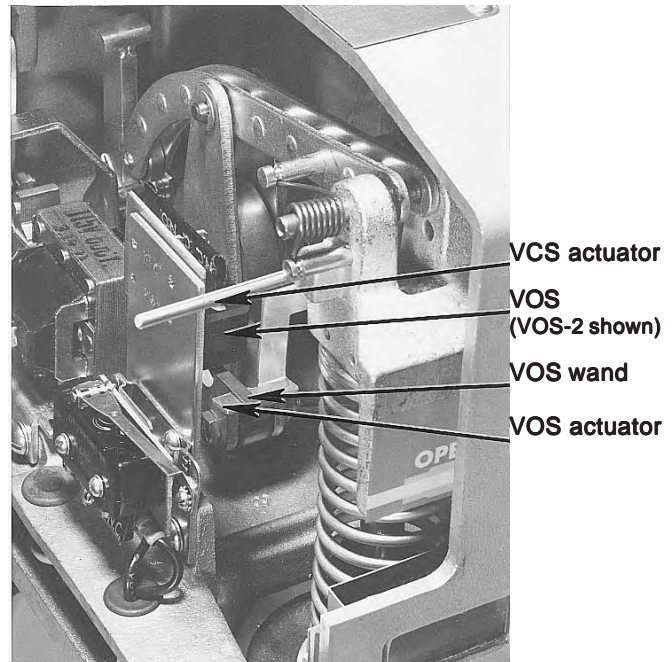

Valve Open

Photos above of normally-open valve
(typical for Series STO-MCP (-S), STO-ACP (-S))

All Maxon proof-of-open and proof-of-closure signal switches work in a similar manner; but due to different styles and types of top assembly housings, the switches appear in slightly different positions in the various types of valves. Illustrated below are representative top housings for 4" – 6" Series 7000 (Fig. 3) and .375" – .75" Series 8700 (Fig. 4) valves. Switch locations are noted on sketches.

Fig. 3

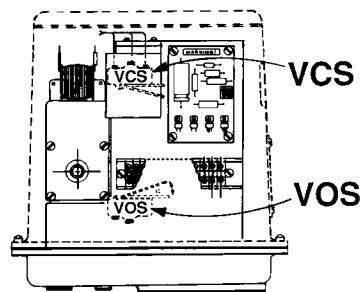
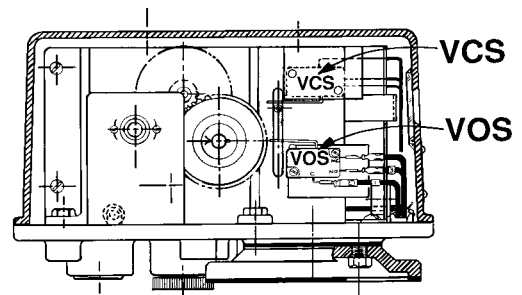

Fig. 4



Tandem Arrangements

(for simultaneous opening of main and blocking valves)

General

Wherever insurance underwriters or other regulatory groups require the use of a double-valve or "block-and-bleed" system, but manual operation is preferred to the use of automatic reset valves, operation can be simplified by adding a tandem arrangement to a pair of Maxon manual reset shut-off valves.

A linkage overtravel spring in the tandem arrangement latches the blocking valve just before the main valve is latched, assuring latching of both valves.

If it is necessary to locate a tandem valve above arms reach, an overhead wheel and chain assembly may be added which includes a loop of chain accessible to operating personnel.

To order

Valves are to be specified in the usual manner and must be in top assembly position TO or AW.

VOS and VCS switches must be included on the main valve and a VOS switch on the blocking valve to permit electrical connection as shown in the wiring schematic illustrated at right.

If overhead wheel and chain assembly is also required, specify loop length to reach appropriate operating position. Extra chain (in one foot increments) may be specified.

Center line distance between valves must be within the ranges indicated in Table 1 and shown in sketch below and must be specified at the time of order.

Wiring Schematic

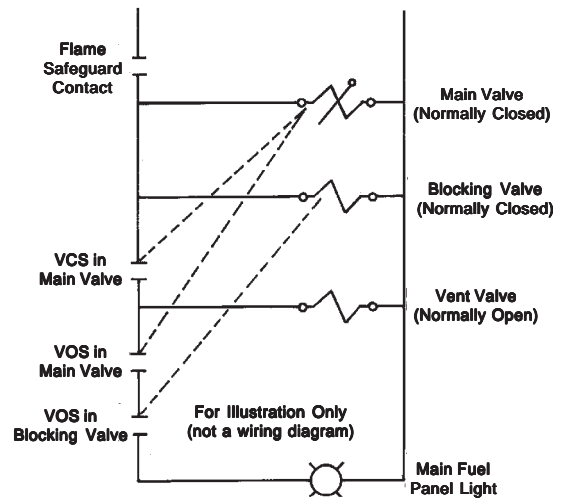

Main valve and blocking valve wired in parallel.
VCS Switch on main valve powers vent valve.
VOS Switches on main and blocking valves wired in series to signal light.

Table 1: Allowable Valve Spacing for Tandem Arrgt.

Valve Size	Minimum C-C	Maximum C-C
.75" – 1.5"	18"	24"
2" – 3"	20"	27"
4" & 6"	27"	33"

Tandem Arrangement with Overhead Wheel & Chain

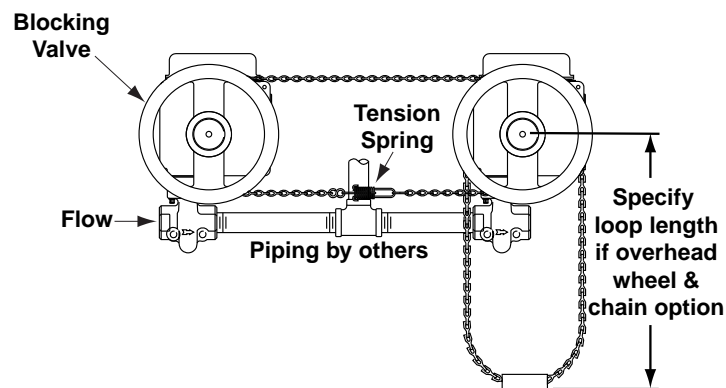

Tandem Arrangement

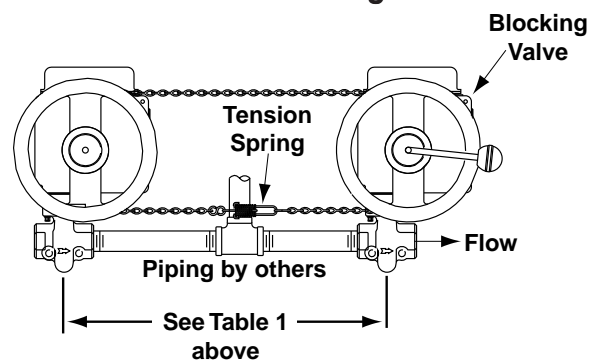

Overhead Wheel & Chain Assembly

Overhead wheel and chain assembly allows operation of a manual reset valve in an otherwise inaccessible overhead location. A wheel is mounted onto the handle of the valve. The attached chain is weighted on one end and has a paddle handgrip on the other.

Once the valve is electrically energized, pulling down on the paddle will open normally closed versions or close normally open versions.

Maxon valve's free-handle design permits valve to trip to its rest position on any power interruption.

Wheel and chain assembly includes a length of chain to position the paddle handgrip slightly below pipe centerline. A standard length of 7 feet of chain is included with CP and larger valve sizes and 5 feet is included with all other valves. Extra chain (in one foot increments) may be specified to fit your specific location.

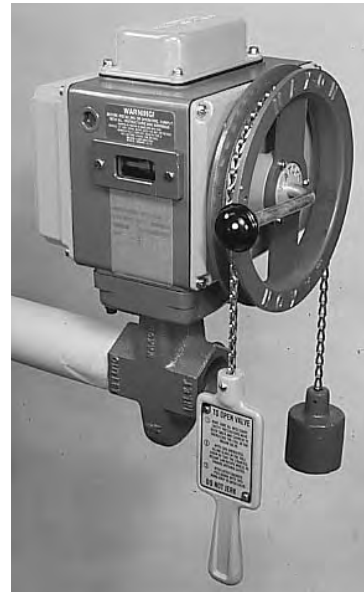

Approximate envelope dimensions *(nominal, in inches)*

Swinging gate valves

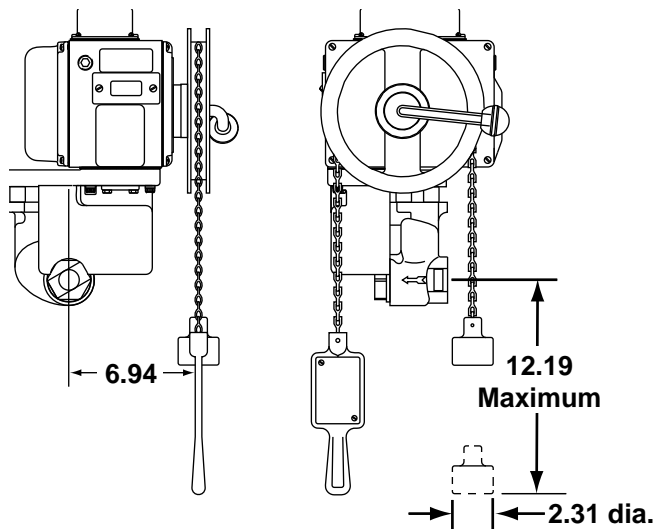

Rising stem valves

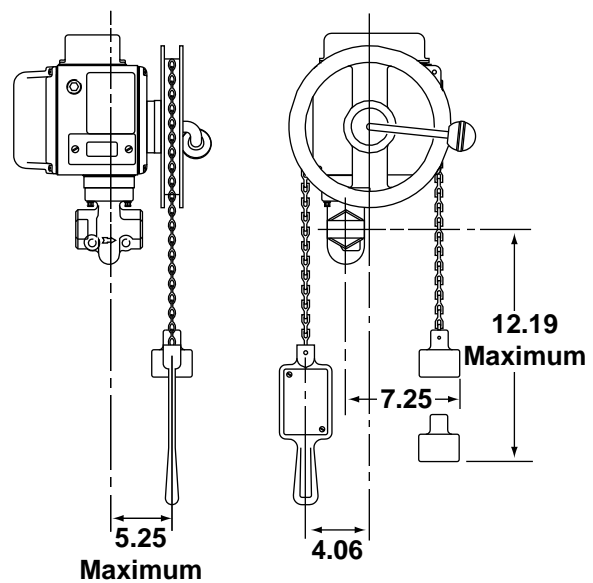

NOTE: Overhead wheel & chain can only be mounted on swinging gate valves with the top assembly position TO.