

HC900 Freeze Dryer Control

Industry: Pharmaceutical

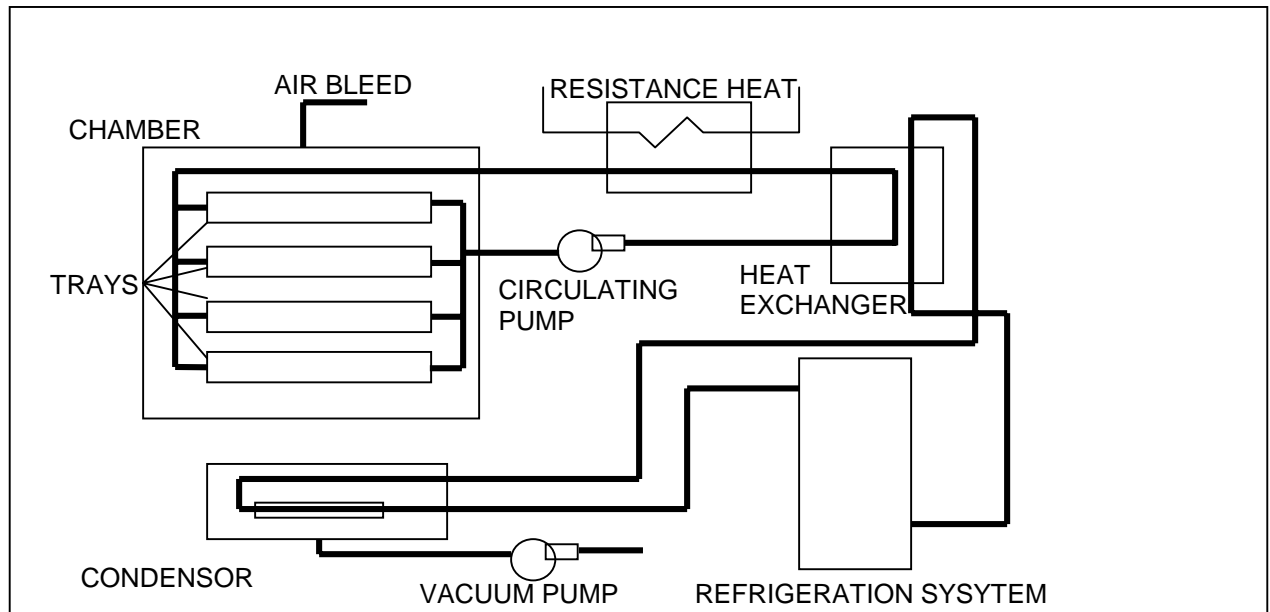

Problem

Freeze drying under high vacuum is used extensively to increase the storage life of products. Freeze drying is a batch process that requires time sequencing and close control of several variables to produce consistent results.

Precise control is required because product damage can result if temperature and vacuum profiles are not maintained throughout the process cycle. Control program requirements will vary from product to product, although all use the same process equipment and control system.

The HC900 meets all of the requirements for safe and productive process operation with maximum operator convenience:

- Program control of variables versus time
- Proportional (PID) modulating loop control
- Logic functions for equipment and process status
- Alarm detection, annunciation, and logging
- Data acquisition and data logging
- Recipe selection for fast, accurate product changeover

The complete process cycle is controlled by the HC900 without operator intervention, providing consistent product quality by executing cycle specifications exactly and repetitively without the variations typical of manual control.

Data must be obtained and stored for reports used for process analysis, product traceability, and Good Manufacturing Practices (GMP) documentation. Since requirements vary from one product to another, the control system must be able to store and execute numerous "recipes". The HC900 Hybrid Controller recipe feature provides the ability to produce a wide breadth of product variations.

The HC900 Solution

The HC900 Hybrid Controller meets all of the requirements for safe and productive process operation with maximum operator convenience:

- Program control of sequencing and variables versus time
- Proportional (PID) modulating loop control
- Logic functions for equipment and process status
- Alarm detection, annunciation, and logging
- Data acquisition and data logging
- Recipe configuration, local storage and download capability

HC900 Freeze Dryer Control

Solution (Continued)

The Sequencer capability of the HC900 is used to control the initial and final vacuum profiles.

Up to 20 different sequences, appropriate for a wide range of products, can be created and stored for use when these products are processed.

A single configurable database integrates both the loop (proportional, modulating) functions and the logic (discrete, boolean) functions required by the freeze drying process.

Familiar operator displays provide the operator with dynamic information about the status of each run as it progresses. Alarms are annunciated in color on dedicated displays and can be acknowledged directly from the Model 1042 Operator Interface (OI). Product changeover is simplified as new recipes may be selected by name directly from the OI.

The data acquisition and control capability of the HC900 permits ongoing process analysis to define and implement the control strategies while maintaining high production with safety and at low cost.

Benefit Summary

The Honeywell HC900 provides the following benefits when used in freeze dryer applications:

- Extensive set of advanced algorithms for maximum process performance
- Ethernet connectivity using Modbus/TCP protocol for easy plant wide integration
- Extensive equipment diagnostic and monitoring to maximize process availability
- A common configuration tool for both control and local OI minimizing engineering costs
- Autotuning and fuzzy overshoot protection for quick startup and proper control operation
- Storage of up to 50 recipes for fast, error-free product selection
- Storage of up to 20 sequences. Each sequence may be part of a recipe.

Implementation

Overview. The HC900 Hybrid Controller consists of a panel-mounted controller, available in 3 rack sizes along with remote I/O, connected to a dedicated Operator Interface (OI).

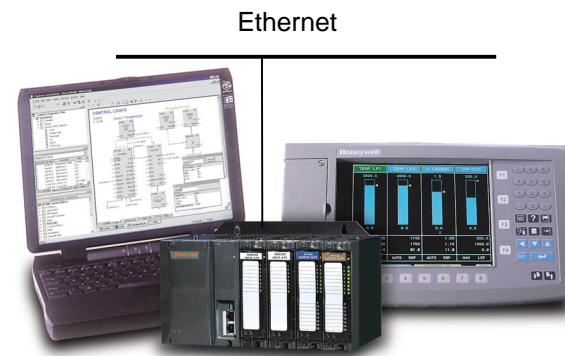

HC900 Hybrid Controller, Model 1042 OI and Hybrid Control Designer Software

All field signals terminate at the controller. The controller has universal analog inputs, analog outputs and a wide variety of digital input and output types. This controller will provide all the freeze dryer control functions.

Configuration. The Hybrid Control Designer tool provides advanced configuration techniques allow a variety of strategies to be easily implemented. The run-mode configuration monitoring and editing capability allows these strategies to be tested and refined as process knowledge is gained.

Monitoring. The complete operation can be monitored and controlled from the easy to use, familiar displays of the Model 1042 OI.

Data Storage. The data storage feature of the OI can be used to log process information during the cycle to an integral floppy disk for a permanent record.

Open Connectivity Over Ethernet. Use popular HMI, data acquisition, OPC server, and HC900's HC Designer configuration software over an Ethernet LAN concurrently to access HC900 controllers.

Peer to Peer Communications. Any HC900 can support up to 8 peer controllers for exchange of analog or digital data over Ethernet.