

SD62
 Rev 11
 March 2011
 Supersedes Rev 10

Model Series 62 Constant Differential Relay

INTRODUCTION

The Constant Differential Relay maintains a constant pressure drop across an internal needle valve for any flow setting up to about 2.1 cubic feet of air per hour. It thus provides a means for maintaining a practically constant volumetric rate of flow regardless of variations of the process or supply pressures. The differential maintained across the needle valve is 1 to 2 psig. This permits a greater opening of the needle valve, thus making it less subject to clogging. The constant differential relay may be used in conjunction with a rotameter type indicator.

The differential applied to the internal needle valve is determined by a spring-loaded diaphragm in the constant differential relay. This diaphragm controls the action of a valve plunger to automatically admit supply air to the needle valve at the required rate. A self-contained automatic bleed discharges excess supply air to the atmosphere when necessary. The constant differential relay is made of aluminum, brass, stainless steel, Neoprene and Buna-N. The rotameter is constructed of aluminum, stainless steel, borosilicate glass, Buna-N (O-rings), ruby sapphire (float) and brass (fittings). Neither will be affected by ordinary air line impurities.

This instruction has five major sections: Introduction, Installation, Operation, Maintenance, and Parts List.

Model Designation

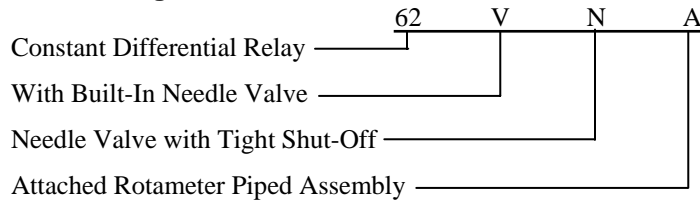

Specifications

Supply Pressure

Minimum..... At least 5 psig greater than the maximum downstream pressure.

Maximum 150 psig

Purge Rate:

	Models 62V & 62VA		Models 62VN & 62VNA	
Maximum	2.1 SCFH	991 SCCM	1.8 SCFH	850 SCCM
Minimum	0.9 SCFH	425 SCCM	0.06 SCFH	28 SCCM

Ambient Temperature Limits -40° to +180°F (-40° to +82°C)

INSTALLATION

Shipping and Storage

If the relay is to be stocked, stored, or shipped to another location prior to piping, make sure that the factory installed plastic plugs are in the ports to prevent entry of moisture, dirt, or other contaminants.

Mounting

Mounting dimensions and the locations and sizes of the pipe connections are shown in Figures 1 and 2. Connect the inlet to a filtered air supply of at least 5 psi greater than the maximum process pressure (including the liquid head). It is not necessary that the supply pressure be regulated although this is generally preferable. A filter in the supply line is very desirable as it will minimize possible clogging of the needle valve. See Instrument Air Requirements below.

Blow out all piping before connections are made to prevent the possibility of dirt or chips entering the relay. Use pipe sealant sparingly, and then only on the male threads. A non-hardening sealant is strongly recommended.

CAUTION

Exceeding the specified ambient temperature limits can adversely affect performance and may cause damage to the instrument.

CAUTION

Supply pressure in excess of 150 psig may cause damage to the instrument.

Figure 3 shows an application example. The piping between the end of the dip tube and the junction of the instrument connection to the bubbling line should be kept as short as possible and should be at least 1/4" pipe or larger. For example: At a flow rate of 0.9 SCFH, the pressure drop in a 20-foot length of 1/4" pipe will not exceed 0.20" H₂O head but approximately ten times this drop would be obtained with 1/4" O.D. tubing. Pressure drop between the relay and the junction of the receiving instrument is ordinarily of no consequence, so that this line may be made any desired size.

Instrument Air Requirements

Connect the instrument to a source of clean, dry, oil-free instrument air. Failure to do so will increase the possibility of a malfunction or a deviation from specified performance.

CAUTION



Use of process fluids other than instrument air is not recommended. No claim is made as to the suitability of this product for use with other process fluids, such as hazardous gases, except as listed on the appropriate certificate. Non-approved instruments are suitable for use with instrument air only. Optional features and modifications such as tapped exhaust do not imply suitability for use with hazardous gases except as listed on the approval certificate.

There are many types of synthetic compressor lubricants. Some may not be compatible with the materials used in construction of the instrument – see the list of materials on page 1. Wetting of these materials by such an oil mist or vapor, etc., may cause them to deteriorate. This may ultimately result in failure of the positioner.

CAUTION

Synthetic compressor lubricants in the air stream at the instrument may cause it to fail.

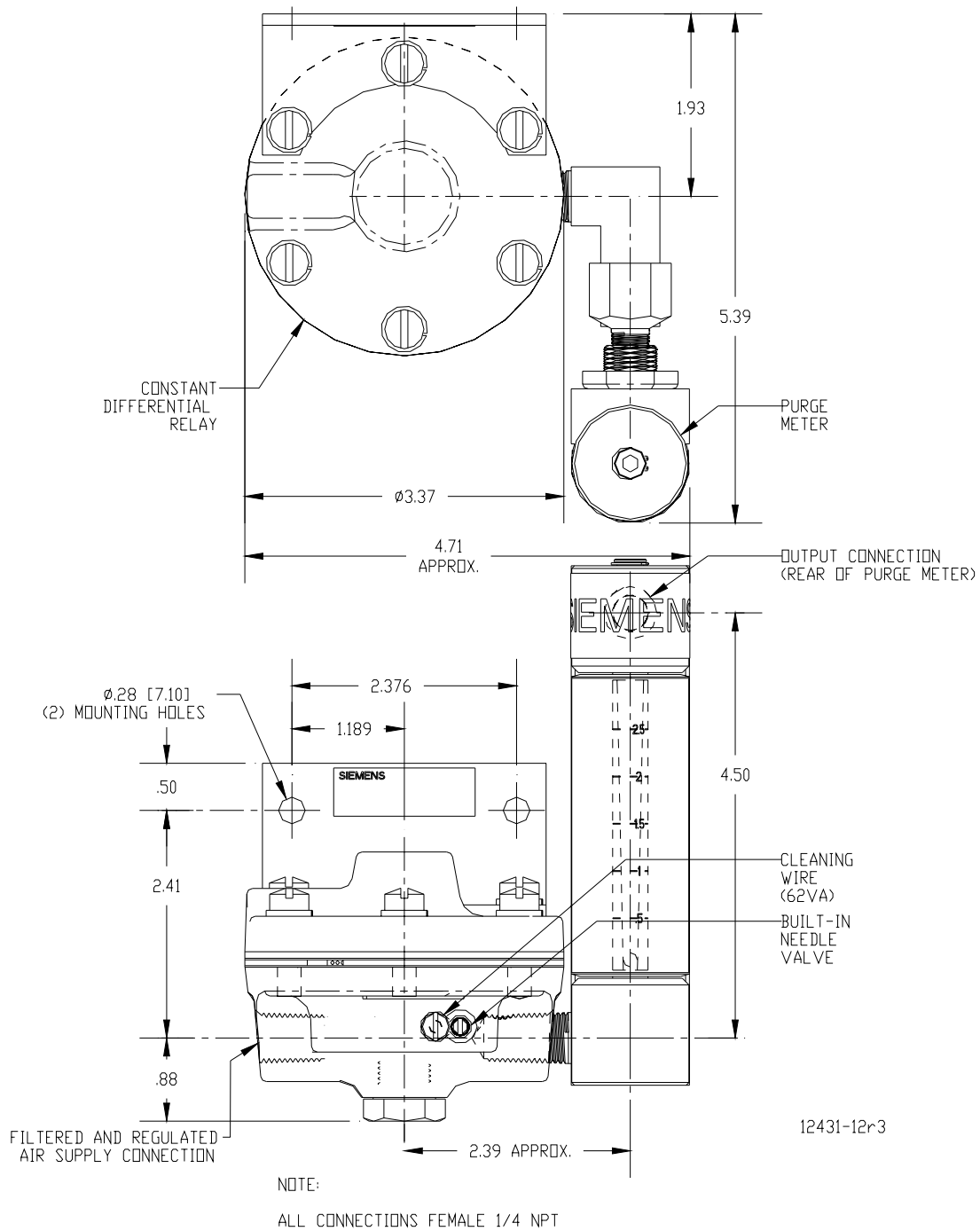

Figure 1 Installation Dimensions with Rounded Rotameter

Notes:

1. All Connections are 1/4" NPT Female.
2. Dimensions are in Inches (Millimeters). Asterisk = Approximate.
3. Bracket Mounting Holes are 9/32 dia.

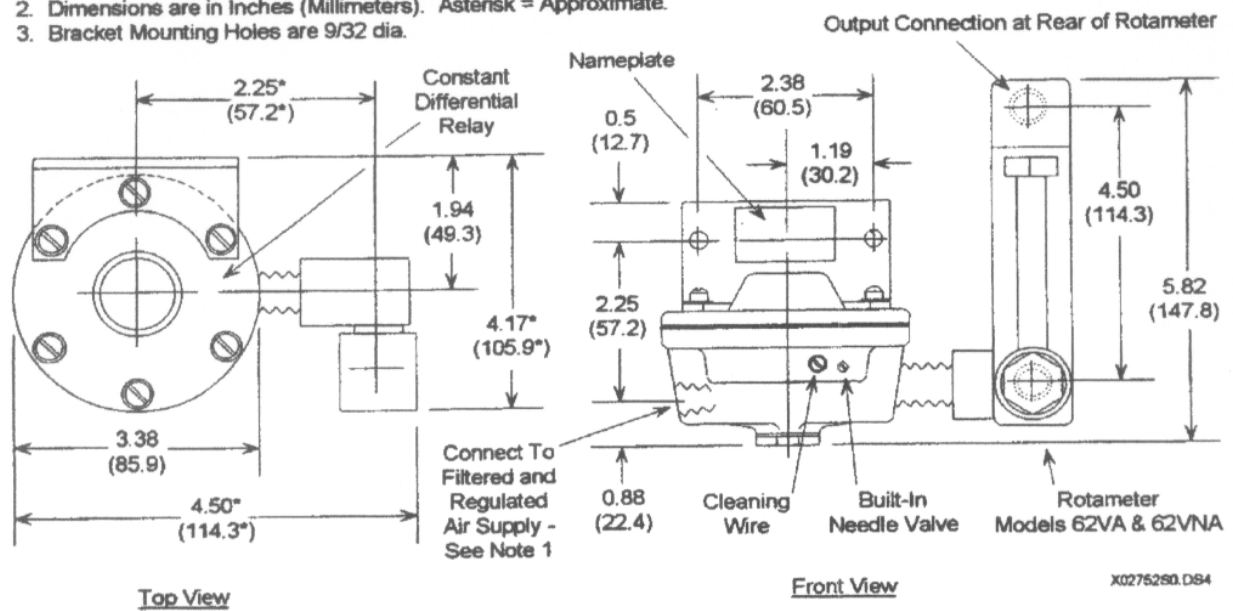

Figure 2 Installation Dimensions with Rectangular Rotameter¹

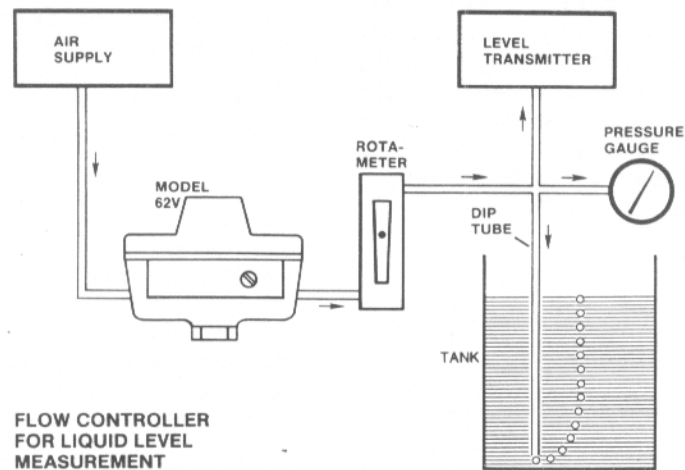

Figure 3 Application Example

The requirements for a quality instrument air supply can be found in the Instrument Society of America's "Quality Standard for Instrument Air" (ISA-S7.3). Basically, this standard calls for the following:

Particle Size — Maximum particle size in the air stream at the instrument should be no larger than 3 microns.

Dew Point — The dew point, at line pressure, should be at least 10°C (18°F) below the minimum temperature to which any part of the instrument air system is exposed at any season of the year. Under no circumstances should the dew point, at line pressure, exceed 2°C (35.6°F).

Oil Content — Maximum total oil or hydrocarbon content, exclusive of non-condensable, should not exceed 1 ppm under normal operating conditions.

¹ Rectangular rotameter discontinued; superseded by rounded rotameter shown in Figure 1 and on Page 1

OPERATION

With the air supply on, turn the needle valve to obtain the desired flow rate. The best rate will depend on the volume of air in the system and the desired speed of response to level changes. Ordinarily, a rate of 0.9 SCFH (minimum flow for Model 62V) is considered satisfactory, although this may have to be increased to obtain the desired speed of response, particularly if the system contains much volume or is subject to rapid pressure or level fluctuations. The flow rate should be checked to make sure it is not excessive, by noting that the receiving meter does not change by an objectionable amount when the flow rate is doubled.

The Model 62V relay may be used with or without a flow indicator in the downstream line. This is possible since the needle valve in the Model 62V has an internal bypass which permits a minimum flow of 0.9 SCFH even with the adjusting screw seated. This prevents possible damage to the process by eliminating the chance of shutting down the operation of the system by turning the screw in.

The Model 62VN differs from the Model 62V in that the internal bypass has been eliminated. This permits flows of less than 0.9 SCFH. It is recommended that a flow indicator be used in the downstream line since it is possible to shut this unit off completely.

MAINTENANCE

The use of a Constant Differential Relay greatly reduces the maintenance ordinarily required with the conventional purging or bubbling system. The rate of flow of the purging gas can be expected to remain constant over long periods of time. Any change in this rate is probably caused by partial clogging of the needle valve and can easily be corrected by screwing the valve in, then resetting to the desired flow rate. In case of severe clogging, due to the presence of excessive dirt in the air supply line, it may be necessary to remove the needle valve for a thorough cleaning.

No lubrication of any sort is required for the constant differential relay.

When disassembling the unit, make sure all parts are clean and free of dirt and debris. Reassembly is the reverse order of disassembly. Make sure not to damage the O-ring(s) and diaphragm(s) when reassembling the unit.

Parts Replacement

Refer to the Parts List at the back of this instruction when performing maintenance. It provides a list of replacement parts and a schematic of the instrument.

CAUTION

Before disassembling the instrument, turn off supply air pressure to the instrument.

Customer/Product Support

For support and the location of your local Siemens representative, refer to the table below for the URL of the Process Instrumentation (PI) portion of the Siemens public Internet site. Once at the site, click **Support** in the right column and then **Product Support**. Next select the type of support desired: sales, technical (see the table below), documentation, or software.

Online Support Request	http://www.siemens.com/automation/support-request
Technical Support	1-800-333-7421; 8 a.m. to 4:45 p.m. eastern time, Monday through Friday (except holidays)
Customer Service & Returns	1-800-365-8766 (warranty and non-warranty)
Public Internet Site	http://www.usa.siemens.com/pi
Technical Publications in PDF	Click the above link to go to the PI home page. Click Support and then Manuals and then, under "Additional Manuals," select the product line (e.g. Control Solutions)

Warranty

The sales contract contains the entire obligation of Siemens. The warranty contained in the contract between the parties is the sole warranty of Siemens. Any statements continued herein do not create new warranties or modify the existing warranty.

All product designations may be trademarks or product names of Siemens Industry, Inc. or other supplier companies whose use by third parties for their own purposes could violate the rights of the owners.

Siemens Industry, Inc. assumes no liability for errors or omissions in this document or for the application and use of information in this document. The information herein is subject to change without notice.

Procedures in this document have been reviewed for compliance with applicable approval agency requirements and are considered sound practice. Neither Siemens Industry, Inc. nor these agencies are responsible for product uses not included in the approval certification(s) or for repairs or modifications made by the user.

PARTS LIST**Siemens Model 62 Constant Differential Relay, Models 62V and 62VN**

Drawing 7135PL

Rev 03/11 Supersedes 11/94

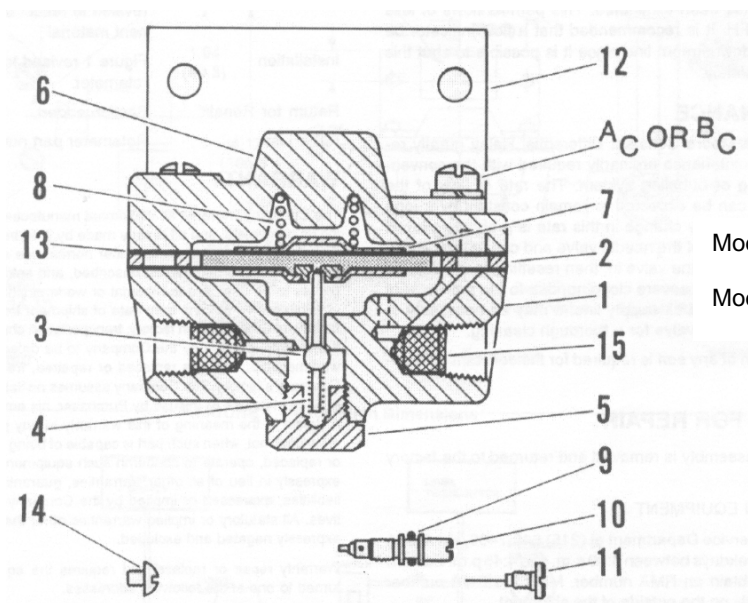

Model 62V - B/M 7135S12

Model 62VN - B/M 8912S11

Item	Part Number	Description	Req'd
1	7135-2	Bottom Forging	1
*2	1447-3	Exhaust Diaphragm Assy.	1
*3	2155-244	Plunger Assy.	1
*4	2155-7	Valve Spring	1
5	2155-6	Retaining Nut	1
6	7135-16	Top Forging	1
*7	1032-3	Diaphragm Disc	1
*8	572-31	Differential Spring	1
*9	2938-5	O-Ring	1
*10a	7135-8	Restriction Screw (Model 62V)	1
*10b	8912-2	Restriction Screw (Model 63VN)	1
*11	7135-9	Cleaning Wire (Model 62V only)	1
12	1145-19	Mounting Bracket	1
13	7135-19	Diaphragm	1
14	8912-10	Retaining Screw (Model 62VN only)	1
15	2155-225	Filter Screen	2
---	A6X30060272	Rotameter, Rounded (Not shown, "A" Models only); Supersedes the following part	1
---	12431-11	Rotameter, Rectangular (Not shown, "A" Models only); Discontinued part	---
A	1-3345	1/4-20 x 7/8 Lg. Fil. HD. Screw	3
B	1-3410	1/4-20 x 1 Lg. Fil. Hd. Screw	3
C	1-7303	1/4 Med. Lockwasher	6

* Recommended on-hand spare parts. Always specify range, serial number, and other nameplate information when ordering.

IMPORTANT

Service Parts Kits are available for servicing the instrument. Contact Siemens for available kits; refer to the Customer/Product Support section of this instruction. Some parts in this Parts List may not be available for separate purchase.